

# SMARTLIVING

S E C U R I T Y S Y S T E M S

Certified by

**IMQ - Security systems**

CEI 79-2  
EN 50131-3  
EN 50131-6  
T014



## GameOver

**inim**<sup>®</sup>  
ELECTRONICS

INSTALLATION

AND

PROGRAMMING

MANUAL

INIM Electronics s.r.l. (Seller, Our, Us) warrants the original purchaser that this product shall be free from defects in materials and workmanship under normal use for a period of 24 months. As INIM Electronics s.r.l. does not install this product directly, and due to the possibility that it may be used with other equipment not approved by Us; INIM Electronics s.r.l. does not warrant against loss of quality, degradation of performance of this product or actual damage that results from the use of products, parts or other replaceable items (such as consumables) that are neither made nor recommended by INIM Electronics. Seller obligation and liability under this warranty is expressly limited to repairing or replacing, at Seller's option, any product not meeting the specifications. In no event shall INIM Electronics s.r.l. be liable to the purchaser or any other person for any loss or damage whether direct or indirect or consequential or incidental, including without limitation, any damages for lost profits, stolen goods, or claims by any other party caused by defective products or otherwise arising from the incorrect or otherwise improper installation or use of this product.

This warranty applies only to defects in parts and workmanship relating to normal use. It does not cover:

- damage arising from improper maintenance or negligence
- damage caused by fire, flood, wind or lightning
- vandalism
- fair wear and tear

INIM Electronics s.r.l. shall, at its option, repair or replace any defective products. Improper use, that is, use for purposes other than those mentioned in this manual will void the warranty. Contact Our authorized dealer, or visit our website for further information regarding this warranty.

INIM Electronics s.r.l. shall not be liable to the purchaser or any other person for damage arising from improper storage, handling or use of this product.

Installation of this Product must be carried out by qualified persons appointed by INIM Electronics. Installation of this Product must be carried out in accordance with Our instructions in the product manual.

The information contained in this document is the sole property of INIM Electronics s.r.l. No part may be copied without written authorization from INIM Electronics s.r.l.

All rights reserved.

Hereby INIM Electronics s.r.l. declares that the SmartLiving series of intrusion-control panels, the Air2 series of devices and the SmartLink product are in compliance with the essential requirements and other relevant provisions of Directive 1999/5/CE.

Moreover, INIM Electronics s.r.l. also declares that all other devices mentioned in this manual are in compliance with the essential requirements and other relevant provisions of Directive 2004/108/CE.

The full declarations of conformity can be found at URL: [www.inim.biz/dc.html](http://www.inim.biz/dc.html).

The devices described in this manual, in accordance with the settings selected during the installation phase and the following illustrated guidelines are, alternatively, in compliance with the the Italian Normative CEI 79-2:1998+Ab:2000 performance level 2 or European Normative CEI EN 50131-3:2009 (in reference to Control and indicating equipment - intrusion control panels) and CEI EN 50131-6:2008 (in reference to Power supplies) security grade 2.

In support of research, development, installation, testing, commissioning and maintenance of intrusion alarm systems installed in buildings please refer to the following normative documents:

CEI 79-3 e CEI CLC/TS 50131-7.

When installing INIM systems, it is up to the installer company to install systems equipped with Normative CEI 79-2 compliant devices rather than devices compliant with European Normatives series EN50131 within and not over the DOWs summarized in amendment CEI 79-2;V1:2010.

## Warranty

## Limited Warranty

## Copyright

## European Directive compliance

## State-of-the-art Installations (DM 37/08)

# Table of contents

- Warranty . . . . . 2
- Limited Warranty . . . . . 2
- Copyright . . . . . 2
- European Directive compliance. . . . . 2
- State-of-the-art Installations (DM 37/08) . . . . . 2
- Table of contents . . . . . 3
- About this manual . . . . . 5
- 0-1 Terminology . . . . . 5
- 0-2 Graphic conventions. . . . . 5
- Chapter 1 General information . . . . . 6**
  - 1-1 Manufacturer's details . . . . . 6
  - 1-2 Description of the product and various models . . . . . 6
  - 1-3 Products certified and conforming to directives . . . . . 6
  - 1-4 Patents Pending. . . . . 7
  - 1-5 Manuals . . . . . 8
  - 1-6 Operator Qualifications. . . . . 8
  - 1-7 Access Levels . . . . . 8
  - 1-8 Conventions – Glossary . . . . . 8
- Chapter 2 The control panel and peripherals. . . . . 9**
  - 2-1 Environmental Conditions . . . . . 9
  - 2-2 SmartLiving intrusion control panels . . . . . 9
  - 2-3 Peripherals . . . . . 13
- Chapter 3 Installation . . . . . 19**
  - 3-1 Installing the control panel . . . . . 19
  - 3-2 Connecting peripherals . . . . . 24
  - 3-3 Addressing the peripherals . . . . . 28
  - 3-4 Auto-enrolling peripherals. . . . . 30
  - 3-5 Wiring and balancing alarm detectors. . . . . 30
  - 3-6 Wiring and balancing rollerblind/shock sensors . . . . . 32
  - 3-7 Connecting wireless detectors . . . . . 33
  - 3-8 Learn Zone Balancing. . . . . 33
  - 3-9 Connecting the outputs . . . . . 33
  - 3-10 Attachment boards . . . . . 34
- Chapter 4 First power up . . . . . 37**
- Chapter 5 Installation project via SmartLeague software . . . . . 38**
  - 5-1 The SmartLeague software programme . . . . . 38
  - 5-2 Using the software programme . . . . . 39
  - 5-3 Creating a Project layout . . . . . 39
- Chapter 6 Options and programming methods . . . . . 41**
  - 6-1 Introduction . . . . . 41
  - 6-2 Programming from a keypad (accessing the installer menu) . . . . . 41

6-3	Programming via the SmartLeague programme . . . . .	42
6-4	Panel options . . . . .	42
6-5	Terminals . . . . .	44
6-6	Zones . . . . .	46
6-7	Outputs . . . . .	50
6-8	Telephone . . . . .	51
6-9	Events . . . . .	52
6-10	Timer . . . . .	59
6-11	Partitions . . . . .	60
6-12	User Codes . . . . .	61
6-13	Installer codes . . . . .	63
6-14	Keys . . . . .	63
6-15	Arming scenarios . . . . .	65
6-16	Shortcuts . . . . .	65
6-17	Expansions . . . . .	66
6-18	Keypads . . . . .	66
6-19	Readers . . . . .	67
6-20	Sounders . . . . .	68
6-21	Language . . . . .	68
6-22	Messages . . . . .	69
6-23	Default settings . . . . .	69
6-24	User functions . . . . .	71
6-25	Other parameters . . . . .	72
6-26	Programming the Nexus . . . . .	74
<b>Chapter 7</b>	<b>Errors and faults . . . . .</b>	<b>78</b>
7-1	Faults detected by the control panel . . . . .	78
7-2	Communication BUS (I-BUS) . . . . .	79
7-3	LED activity . . . . .	79
7-4	Ring Sensitivity . . . . .	80
<b>Appendix A</b>	<b>Technical terminology and Glossary . . . . .</b>	<b>81</b>
<b>Appendix B</b>	<b>Shortcuts at default . . . . .</b>	<b>89</b>
<b>Appendix C</b>	<b>Available icons . . . . .</b>	<b>90</b>
<b>Appendix D</b>	<b>Voice messages . . . . .</b>	<b>91</b>
<b>Appendix E</b>	<b>Screw Terminals . . . . .</b>	<b>93</b>
<b>Appendix F</b>	<b>Combination of outputs triggered by events . . . . .</b>	<b>94</b>
<b>Appendix G</b>	<b>Compliance with the regulations in force . . . . .</b>	<b>95</b>
<b>Appendix H</b>	<b>Order Codes . . . . .</b>	<b>97</b>
	Notes . . . . .	99

# ABOUT THIS MANUAL

DCMIINE0SLIVINGE **MANUAL CODE**  
4.10 **VERSION**

## Terminology **0-1**

The main supervisory unit and any constituent parts of the SmartLiving intrusion control system.

Directions as seen by the operator when directly in front of the mounted device.

A device which sends voice calls or digital reports to programmed contact numbers in the event of an alarm.

Persons whose training, expertise and knowledge of the products and laws regarding security systems, are able to create, in accordance with the requirements of the purchaser, the most suitable solution for the protected premises.

Click on a specific item on the interface (from drop-down menu, options box, graphic object, etc.).

Click on a video button, or push a key on the control-panel keypad.

**CONTROL PANEL, SYSTEM, APPARATUS**

**LEFT, RIGHT, BEHIND, ABOVE, BELOW**

**DIALER**



**QUALIFIED PERSONNEL**

**SELECT**

**PRESS**

## Graphic conventions **0-2**

Following are the graphic conventions used in this manual.

Conventions	Example	Description
Text in italics	Refer to <i>paragraph 4.3 Unpacking the device</i>	Indicates the title of a chapter, section, paragraph, table or figure in this manual or other published reference.
<text>	#<AccountCode>	Editable field
[Uppercase letter] or [number]	[A] or [1]	Reference relating to a part of the system or video object.
BUTTON	 ,  , 	Keypad keys

The "Note" sections contain important information relating to the text.

**The "Attention" prompts indicate that total or partial disregard of the procedure could damage the device or its peripherals.**

**The "DANGER" warnings indicate that total or partial disregard of the procedure could injure the operator or persons in the vicinity.**

Similarly marked dialogue boxes contain recommendations and/or guidelines which the manufacturer wishes to call attention to.

**Note**

**ATTENTION!**

**DANGER!**

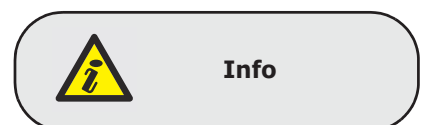

# Chapter 1

## GENERAL INFORMATION

### Manufacturer's details 1-1

Manufacturer:	INIM Electronics s.r.l.
Production plant:	Via Fosso Antico - Centobuchi 63076 Monteprandone (AP) - Italy
Tel:	+39 0735 705007
Fax:	+39 0735 704912
e-mail:	info@inim.biz
Web:	www.inim.biz

Any persons authorized by the manufacturer to repair or replace the parts of this system, hold authorization to work on INIM Electronics brand devices only.

### Description of the product and various models 1-2

Description:	Intrusion control panel
Models:	SmartLiving 505 SmartLiving 515 SmartLiving 1050 SmartLiving 1050L SmartLiving 10100L
Applied Normative:	CEI 79-2:1998+Ab:2000, CEI EN 50131-3:2009 and CEI EN 50131-6:2008
Certification agency:	IMQ Security Systems
Security rating:	2

### Products certified and conforming to directives 1-3

The SmartLiving intrusion control panel and the devices described in this manual have been certified by the IMQ - Security Systems agency as compliant with CEI 79-2:1998+Ab:2000, CEI EN 50131-3:2009 and CEI EN 50131-6:2008, when duly programmed, as described in *Appendix G, Compliancy with the regulations in force*.



The Control panel enclosure houses the following certified devices:

- INIM Electronics switching-power supply
- Motherboard (IN082 or IN088)
- SmartLogos30M voice board (accessory item)
- FLEX5/U input/output expansion board (accessory item)
- AUXREL32 relay board (accessory item)
- SmartLAN/SI and SmartLAN/G LAN interface boards (accessory items)
- IB100/RU BUS isolator board (accessory item)
- ProbeTH thermal-probe kit for battery-charge optimization (accessory item)
- TamperNO tamper-protection kit (accessory item)
- Backup battery, 12 V @ 17 Ah

- Motherboard (IN082 and IN088) integrated Type B notification apparatus

The control panel compliancy is also guaranteed when connected to the following certified devices:

- FLEX5/P input/output expansion boards
- Joy/MAX, Joy/GR, Concept/G, nCode/G keypads
- nBy/S outdoor-mount proximity readers
- nBy/X universal-mount proximity readers
- IB100/RP BUS isolator
- Self-powered IB100/A BUS isolator
- nCard access-control card for proximity readers
- nTag access-control tag for proximity readers

Compliancy is not guaranteed when the control panel is connected to the following uncertified devices:

- SmartLink/GWB GSM interface with 12V @ 1.2 Ah battery
- BUS-connected Nexus interface
- BUS connectable Ivy-B, Ivy-BF, Ivy-BM, and Ivy-BFM self-powered sounderflashers for outdoor installation
- Wireless devices such as: AIR2, AIR2-BS100 (transceivers), Air2-IR100 (PIR detectors), Air2-MC100 (magnetic contacts), Air2-KF100 (access-control keyfobs)
- SmartModem100 Teleservice modem

ATS2 notification apparatus (refer to EN50131-1:2008-02, paragraph 8.6 Notification, Table 10, page 46, Grade 2 and EN50136) characterized by:

- Transmission time - classification D2 (60 seconds)
- Transmission time - max. values M2 (120 seconds)
- Classification time - classification T2 (25 hours)
- S0 Substitution security (no detection of device substitution)
- I0 Information security (no detection of message substitution)

## TYPE B NOTIFICATION APPARATUS

## Patents Pending

## 1-4

The SmartLiving series of control panels employs the following INIM-patented technologies.

- **Input/Output Terminals:** each terminal on-board the control panel, JOY keypads and FLEX5 expansion boards can be configured as either an input or output zone (Split terminal technology).
- **nBy/X proximity reader:** this reader has been especially designed to flush-mount to all models of electrical light-switch backboxes.
- **Learn zone balancing:** this option allows the control panel to save the balancing values of all the system zones automatically, thus eliminating the task of typing them in.

## Manuals 1-5

### Installation and Programming Manual (this manual) 1-5-1

This Manual (not included in the package) can be purchased from your retailer. You (the installer) should read carefully through it in order to become familiar with all the components and operating procedures of the SmartLiving system. In order to provide adequate protection, the installer must adhere to all the manufacturer's guidelines relating to the active and passive security devices of this system. It is the installer's responsibility to inform the system users that, regardless of its capabilities, an intrusion alarm system is not a substitute for the necessary precautions building occupants must take to prevent intrusion.

### User's Manual 1-5-2

The installer should read carefully through the User's Manual (supplied with each control panel). Once the system has been installed, you must ensure that the User's Manual is available to the users for consultation, and that they fully understand how the system works and are aware of all the functions, settings and procedures.

## Operator Qualifications 1-6

### Installer 1-6-1

The installer is the person (or group of persons) who sets up and programs the entire security system in accordance with the purchaser's requirements and in respect of the safety laws in force. As the only individual in contact with system users, it is the installer's responsibility to instruct them on how to use the security system properly.

Under normal circumstances, the installer is not allowed to arm/disarm the system without previous authorization from the user. All the system partitions must be disarmed before accessing the parameter programming phase.

### User 1-6-2

The users are the occupants of the building where this intrusion control panel is installed. Only authorized users can access and operate the system.

The most common operations can be carried out without code/key verification. This operating method must be expressly requested by the main user, as it considerably lowers the security level of the system and may cause false alarms, accidental arm/disarm operations, etc.

## Access Levels 1-7

The normative defines the following system-access levels, regardless of system-access limitations:

- **Level 1** - access by any person (e.g. passer-by)
- **Level 2** - user access
- **Level 3** - installer or maintenance operator access (authorized by user - level 2)
- **Level 4** - manufacturer access

## Conventions – Glossary 1-8

In order to understand the terminology utilized in this manual and improve your knowledge of this system and its operating procedures, read carefully through the Technical Terminology – Glossary (refer to *Appendix A, Technical terminology and Glossary*).

The appendix contains the definitions of technical terms commonly used in the field of security, therefore, relevant to the SmartLiving system.



# Chapter 2

## THE CONTROL PANEL AND PERIPHERALS

### Environmental Conditions 2-1

All control panels from the SmartLiving series are for indoor installation only and operate best under the following conditions:

- **Temperature:** from -10° to +40°C
- **Maximum humidity:** 75% (without condensation)
- **Environmental class:** II

The JOY/GR, JOY/MAX, nCode/G, Concept/G, IB100, FLEX5, Nexus and nBy/X are for indoor installation only and operate best under the following environmental conditions:

- **Temperature:** from -10° to +40°C
- **Maximum humidity:** 75% (without condensation)
- **Environmental class:** II

The nBy/S reader is suitable for indoor and outdoor installation, and operates best under the following conditions:

- **Temperature:** from -25° to +70°C
- **Maximum humidity:** 93% (without condensation)
- **Protection grade:** IP34
- **Environmental class:** IV

### SmartLiving intrusion control panels 2-2

#### Package contents 2-2-1

Inside the package you will find:

- Metal enclosure containing the wired motherboard and power supply (adapter or switching-power supply)
- User's Manual
- Quick Installation Guide
- Plastic bag:

Table 1: Package contents

	505	515	1050	1050L	10100L
<b>3k9Ω 1/4W Resistors</b>	10		20		
<b>6k8Ω 1/4W Resistors</b>	10		20		
<b>150 Vrms Varistors</b>	2				
<b>Backup-battery wire</b>	1				
<b>Screws to secure the frontplate of the metal enclosure</b>	4				
<b>"INIM Electronics security-protected area" sticker</b>	1				

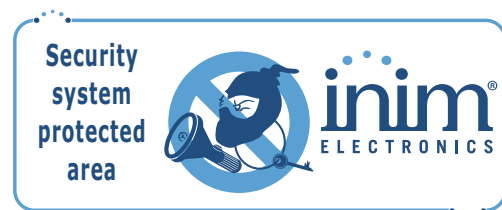

Items not included in the package:

Thermal probe (battery-charge optimizer which operates in accordance with the battery temperature), backup battery, SmartLeague programme CD, Installation Manual. These devices are accessory items which must be purchased separately.

## Control panel descriptions 2-2-2

Table 2: Control panels - electrical specifications and mechanical features

	SmartLiving intrusion control panels				
	505	515	1050	1050L	10100L
<b>Power supply voltage</b>	230V ~ -15% +10% 50/60Hz				
<b>Nominal output voltage</b>	13.8V				
<b>Voltage - operating range</b>	9 - 16 V				
<b>Maximum current draw</b>	0.2A		0.4A		0.6A
<b>Current draw of control panel motherboard</b>	110mA @ 22V~		75mA @ 13.8V=		
<b>Maximum distributable current @ 12V</b>	1.2A		3A		5A
<b>Maximum distributable current to open-collector outputs</b>	150mA		500mA		
<b>Maximum power-supply voltage ripple</b>	340mV		70mV		
<b>Max. battery-charge current</b>	1A		2A		
<b>Backup battery</b>	12V 7Ah			12V 17Ah	
	recharged 80% in 24h				
<b>Max. current across +AUX terminals</b>	900mA		4.05A (1.35A for +AUX1, 1.35A for +AUX2, 1.35A for +AUX3)		
<b>Power supply (EN 50131)</b>	Type A				
<b>Enclosure Dimensions (W x H x D)</b>	21.5 x 30.5 x 8.5cm			37.5 x 51 x 8.5cm	
<b>Weight (without battery)</b>	2.5 Kg		2.2 Kg		5.3 Kg

Compliance with EN 50131, CEI 79 or CEB T014 requires that the values of the maximum distributable current respect determined limits, as indicated in paragraph 3-1-3 *Maximum current - normative references*.

The control panel label (see figure opposite) is located inside the enclosure.

The following table shows the maximum number of devices supported by the various control panel models.

Table 3: Control panel - Main Features

	505	515	1050	1050L	10100L
<b>Total terminals</b>	5	15	50		100
<b>Terminals on panel</b>	5		10		
<b>Terminals on panel configurable as inputs</b>	5		10		
<b>Terminals on panel configurable as Rollerblind/Shock</b>			2		
<b>Terminals on panel configurable as outputs</b>	0		5		
<b>Total zones</b>	10	30	100		200
<b>Outputs on control-panel PCB</b>	3				
<b>Relay outputs on control-panel PCB</b>	1				
<b>Open-collector outputs</b>	2				
<b>Partitions</b>	5		10		15
<b>Keypads (JOY, nCode/G, Concept/G)</b>	5		10		15
<b>Voice memo slots</b>	5		10		15
<b>FLEX5 expansions</b>	5	10	20		40
<b>nBy Readers</b>	10		20		30
<b>Transceivers Air2-BS100</b>	10		20		30
<b>Digital keys and keyfobs</b>	50		100		150
<b>Possible key combinations</b>	4294967296				
<b>IB100 isolators</b>	15				
<b>Nexus dialer</b>	1				
<b>Codes</b>	30		50		100
<b>Scenarios</b>	30				
<b>Timer</b>			10		20
<b>Recordable events</b>			500		1000
<b>Programmable events</b>	10		30		50

**SMARTLIVING 505** 01/2011

EN 50131-3 grade 2  
EN 50131-6 grade 2  
CEI 79-2 livello 2  
CEB T014

Alimentazione / Power Tension / Alimentation: 230V~ -15% + 10% 50/60 Hz  
Consumo / Consumption Consumption / Consumo: 0.2 A  
Classe di Isolamento / Insulation class: I  
Insulation class / Classe aislante: I  
Classe ambientale / Environmental class: II  
Classe d'environnement / Classe ambiental: II

CE, inim ELECTRONICS, MADE IN ITALY, CO280518

LBDTIN4ASLIV05

**SMARTLIVING 515** 01/2011

EN 50131-3 grade 2  
EN 50131-6 grade 2  
CEI 79-2 livello 2  
CEB T014

Alimentazione / Power Tension / Alimentation: 230V~ -15% + 10% 50/60 Hz  
Consumo / Consumption Consumption / Consumo: 0.2 A  
Classe di Isolamento / Insulation class: I  
Insulation class / Classe aislante: I  
Classe ambientale / Environmental class: II  
Classe d'environnement / Classe ambiental: II

CE, inim ELECTRONICS, MADE IN ITALY, CO280518

LBDTIN4ASLIV15

**SMARTLIVING 1050** 01/2011

EN 50131-3 grade 2  
EN 50131-6 grade 2  
CEI 79-2 livello 2  
CEB T014

Alimentazione / Power Tension / Alimentation: 230V~ -15% + 10% 50/60 Hz  
Consumo / Consumption Consumption / Consumo: 0.4 A  
Classe di Isolamento / Insulation class: I  
Insulation class / Classe aislante: I  
Classe ambientale / Environmental class: II  
Classe d'environnement / Classe ambiental: II

CE, inim ELECTRONICS, MADE IN ITALY, CO280517

LBDTIN4ASLIV50

**SMARTLIVING 1050L** 01/2011

EN 50131-3 grade 2  
EN 50131-6 grade 2  
CEI 79-2 livello 2  
CEB T014

Alimentazione / Power Tension / Alimentation: 230V~ -15% + 10% 50/60 Hz  
Consumo / Consumption Consumption / Consumo: 0.4 A  
Classe di Isolamento / Insulation class: I  
Insulation class / Classe aislante: I  
Classe ambientale / Environmental class: II  
Classe d'environnement / Classe ambiental: II

CE, inim ELECTRONICS, MADE IN ITALY, CO280517

LBDTIN4ASLIV50L

**SMARTLIVING 10100L** 01/2011

EN 50131-3 grade 2  
EN 50131-6 grade 2  
CEI 79-2 livello 2  
CEB T014

Alimentazione / Power Tension / Alimentation: 230V~ -15% + 10% 50/60 Hz  
Consumo / Consumption Consumption / Consumo: 0.6 A  
Classe di Isolamento / Insulation class: I  
Insulation class / Classe aislante: I  
Classe ambientale / Environmental class: II  
Classe d'environnement / Classe ambiental: II

CE, inim ELECTRONICS, MADE IN ITALY, CO280517

LBDTIN4ASLIV100L

**Note**

SmartLiving control panels are not equipped with built-in dislodgement-tamper microswitches. For the order code of this accessory item, refer to *Appendix H, Order Codes*.

Table 4: Control panels - description of parts

	Model				
	505	515	1050	1050L	10100L
A	Power adaptor (Transformer)		3A switching power supply		5A switching power supply
B	Mains connection terminal-board (230 Vac) - 50/60 Hz				
C	Power cable - adaptor to control panel		Power cable - switching-power supply to panel		
D			Power cable - switching-power supply to panel		
E	Mains cable entry				
F	Metal enclosure				
G	Anchor-screw locations for the metal backbox				
H	Dislodgement-tamper microswitch location				
I	Backup battery				
J	Backup-battery wire				
K	Backup-battery connector				
L	Thermal probe (accessory item)				
M	Thermal probe connector				
N	Thermal probe (enable/disable) jumper				
O	Connectors for the SmartLAN power-supply jumper				
P	Local I-BUS connector				
Q	Maintenance jumper connectors				
R	SmartLogos30M voice-board connector				
S	Control panel to PC serial cable connector				
T	Dislodgement-tamper microswitch connector (accessory item)				
U	Open-panel tamper microswitch connector (accessory item)				
V	Open-panel tamper microswitch				
W	Terminal board				
X	Blue and yellow activity LEDs				
Y	Firmware version label				
Z	Anchor-screw locations for AUXREL32 board				
A1	Ground connection screws				
B1	FLEX5/U expansion board locations				
C1	Anchor-screw locations for SmartLink board				
D1	SmartLink antenna entry				
E1	SmartLink board battery housing				

SmartLiving 505/515 control-panel motherboard

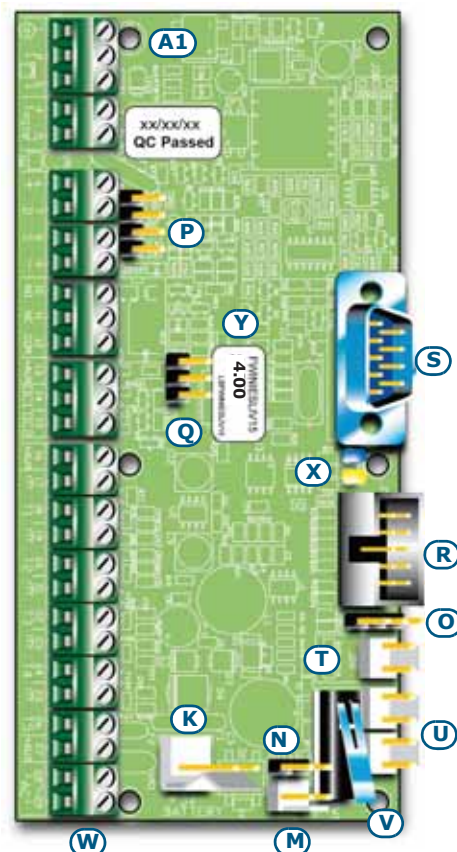

SmartLiving 1050/1050L/10100L Control panel motherboard

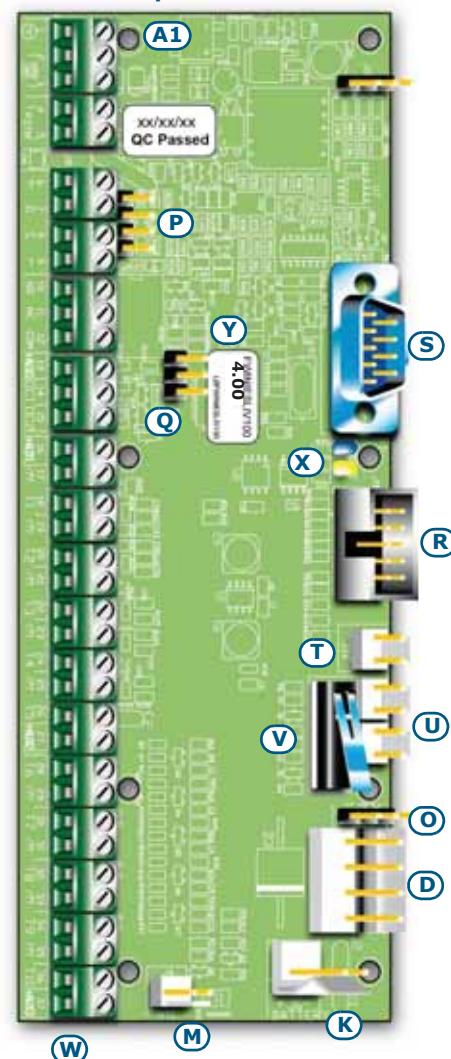
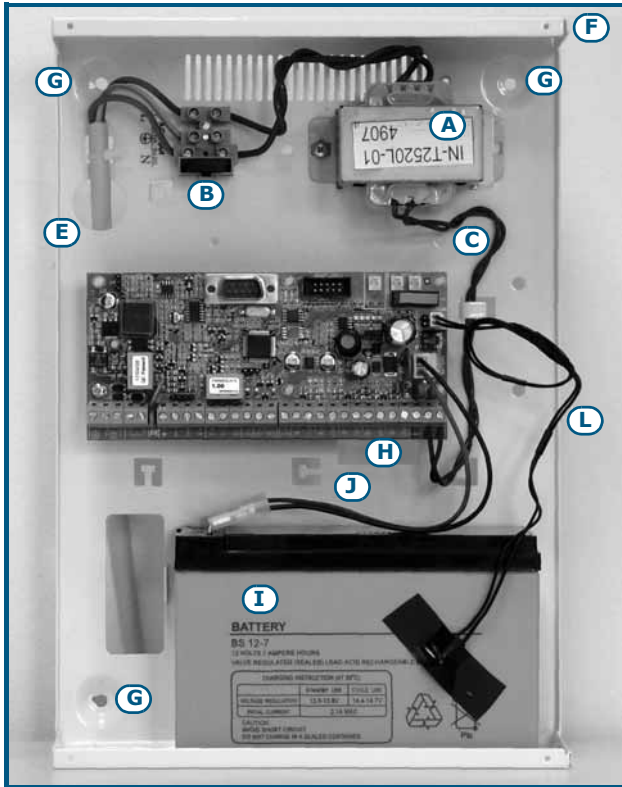
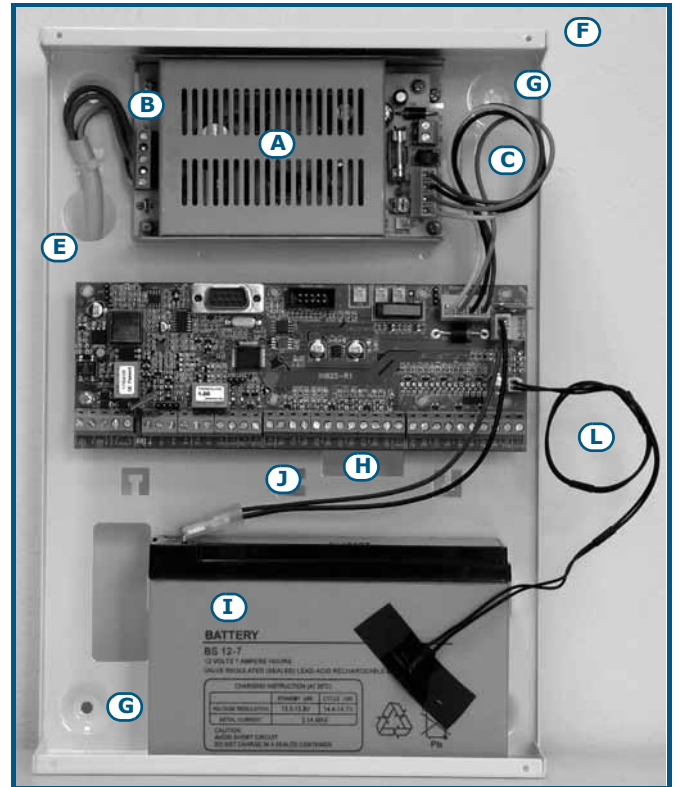

Table 5: Control panel - terminal board

n.	Icon/ Identifier	Model				
		505	515	1050	1050L	10100L
1		Earth connection				
2-3		Internal telephone-line connection				
4-5	PSTN	Land-line connection (PSTN)				
6-7-8-9	+ D S -	I-BUS connection terminals				
10-11-12	NO NC COM	Voltage-free terminals of the relay output				
13	+AUX	12V ancillary power source terminal				
14-15	OC1 OC2	Open-collector output terminals (x2)				
16	+AUX	12V ancillary power source terminal				
17-19-21-23-25		Negative power terminals (Negative or GND)				
18-20-22-24-26	T1-T2-T3-T4-T5	Screw terminals for control panel input terminals: T1, T2, T3, T4 and T5				
27	+AUX	12V ancillary power source terminal				
28-29	AC	Transformer-power input terminals				
28-30-32-34-36	T6-T7-T8-T9-T10			Screw terminals: T6, T7, T8, T9 and T10 of the control panel		
29-31-33-35				Negative power terminals (Negative or GND)		
37	+AUX	12V ancillary power source terminal				



SmartLiving 505/515



SmartLiving 1050

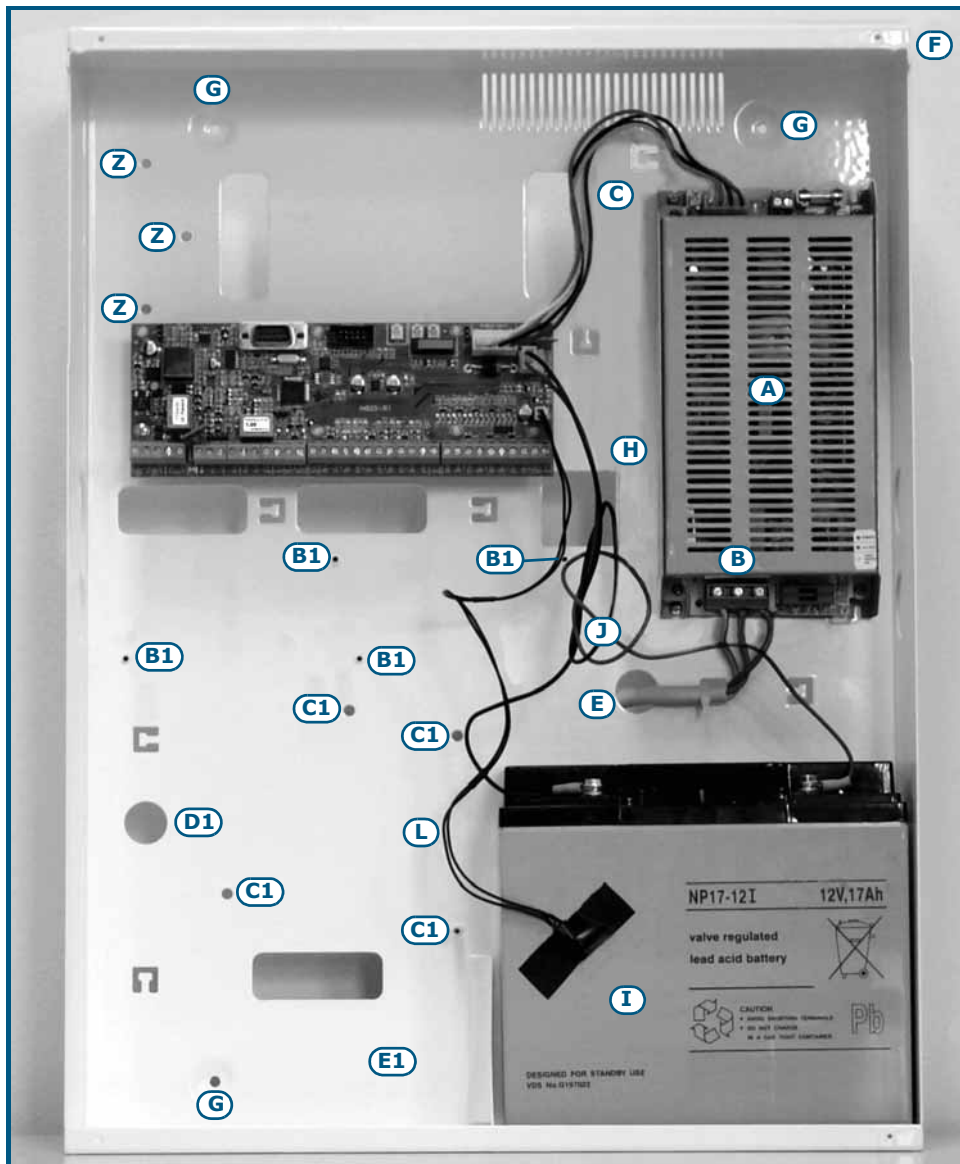

SmartLiving 10100L

## Events log memory 2-2-3

The control panel events are saved to a non-volatile semiconductor-memory which retains data without the need of power.

The electrical characteristics of semiconductor devices diminish over time. However, a minimum period of 40 years data retention is guaranteed.

## I-BUS interconnections 2-2-4

SmartLiving control panels are equipped with a 4-wire BUS for peripheral interconnections (2 power-supply wire and 2 data exchange wires, refer to paragraph 3-2-1 *The I-BUS line wiring*).

The intellectual property rights regarding the electrical, structural and protocol features of the BUS are the sole property of INIM Electronics s.r.l.

The I-BUS is not a RS485 differential BUS.

## Peripherals 2-3

The control panel I-BUS accommodates the following peripherals:

- keypads (JOY/GR, JOY/MAX, nCode/G, Concept/GN)
- Readers (nBy/S and nBy/X)
- Expansions (Flex5)
- Transceivers (Air2-BS100)
- Sounderflashers (Ivy)
- IB100 isolators
- GSM dialer (Nexus)

## Joy/GR and Joy/MAX Keypads 2-3-1

Table 6: Device Specifications

	JOY/GR	JOY/MAX
<b>Voltage [V]</b>	9 - 16	
<b>Typical current draw [mA]</b>	70	90
<b>Terminals configurable as OC outputs</b>	2	
<b>Maximum current draw per terminal [mA]</b>	150	
<b>Dimensions (W x H x D) [mm]</b>	142 x 116 x 20	
<b>Weight [g]</b>	160	180

Table 7: Joy - Description of parts

<b>A</b>	Terminal board
<b>B</b>	Buzzer
<b>C</b>	Microphone (Joy/MAX only)
<b>D</b>	Temperature sensor (Joy/MAX only)
<b>E</b>	Open-tamper microswitch
<b>F</b>	Backlit graphic display
<b>G</b>	Signaling LEDs
<b>H</b>	Antenna (Joy/MAX only)
<b>I</b>	Speaker-wire connector (Joy/MAX only)
<b>J</b>	Wire entry
<b>K</b>	Wall-mount screw locations
<b>L</b>	Speaker housing
<b>M</b>	Board supports
<b>N</b>	Dislodgement-tamper microswitch screw location
<b>O</b>	Dislodgement-tamper microswitch spring

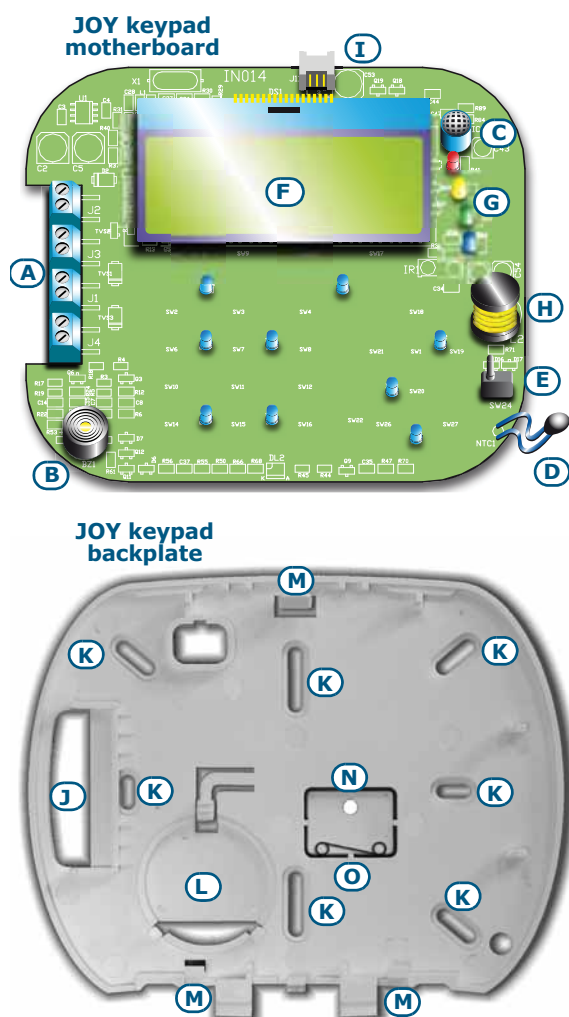

Keypad terminals:

Table 8: **Joy - terminal board**

n.	Icon/ Identifier	description
1	+	Terminal "+" for the I-BUS connection
2	D	Terminal "D" for the I-BUS connection
3	S	Terminal "S" for the I-BUS connection
4	-	Terminal "-" for the I-BUS connection
5	T1	Screw terminal of keypad terminal T1
6		Negative power terminal (Negative or GND)
7	T2	Screw terminal of keypad terminal T2
8		Negative power terminal (Negative or GND)

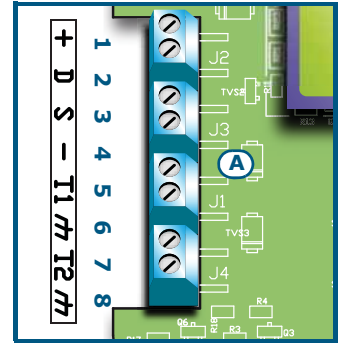

Terminals T1 and T2 can be configured as:

- Input (also as Rollerblind or Shock)
- Output
- Double zone
- Supervised Output

The keypad package contains a sticker (to be located under the keypad flip) which can be used to note down the keypad address or label, its location, the partitions it controls and any phone-contact numbers.

JOY		n.	
<input type="checkbox"/>	A01	<input type="checkbox"/>	A09
<input type="checkbox"/>	A02	<input type="checkbox"/>	A10
<input type="checkbox"/>	A03	<input type="checkbox"/>	A11
<input type="checkbox"/>	A04	<input type="checkbox"/>	A12
<input type="checkbox"/>	A05	<input type="checkbox"/>	A13
<input type="checkbox"/>	A06	<input type="checkbox"/>	A14
<input type="checkbox"/>	A07	<input type="checkbox"/>	A15
<input type="checkbox"/>	A08	<input type="checkbox"/>	☒ -c

## nCode/G and Concept/G Keypads

Table 9: **Device Specifications**

	nCode/G	Concept/G
<b>Voltage [V]</b>	9 - 16	
<b>Typical current draw [mA]</b>	70	80
<b>Terminals configurable as OC outputs</b>	1	
<b>Maximum current draw per terminal [mA]</b>	150	
<b>Dimensions (W x H x D) [mm]</b>	87 x 129 x 18	
<b>Weight [g]</b>	135	155

Table 10: **nCode/G and Concept/G - Description of parts**

<b>A</b>	Backlit graphic display
<b>B</b>	Signaling LEDs
<b>C</b>	Cable connector
<b>D</b>	Tamper microswitch
<b>E</b>	Screw location
<b>F</b>	Screw location
<b>G</b>	Terminal board guide
<b>H</b>	Buzzer

Code/G and Concept/G keypads are equipped with a buzzer and a T1 terminal which can be configured as:

- Input (also as Rollerblind or Shock)
- Output
- Double zone

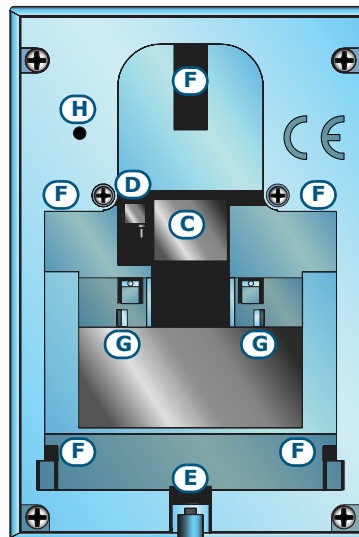

Retro keypads  
nCode/G and Concept/G

## 2-3-2

nCode/G keypad frontplate

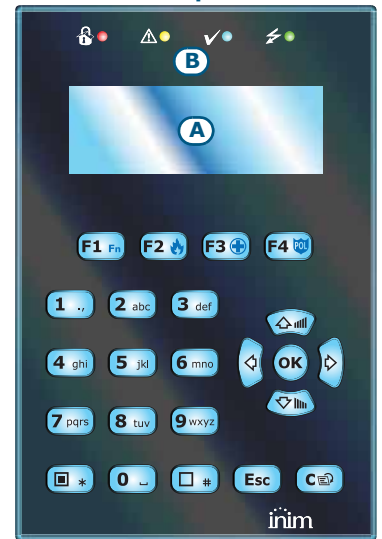

Concept/G keypad frontplate

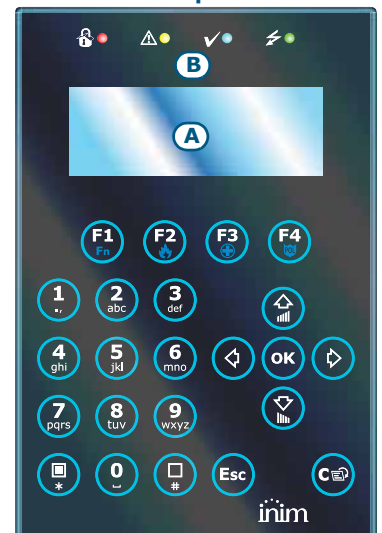

You can connect Code/G and Concept/G keypads using the connector on the back of the device, using either the 6 wire cable (included), or the KB100 terminal board included in the deep-bracket kit (accessory kit).

6 wire cable

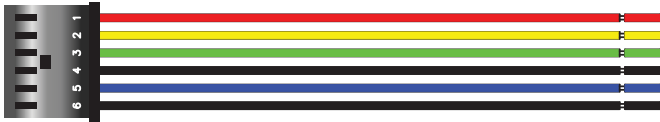

KB100 - terminal board

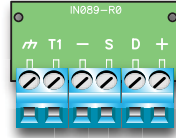

Table 11: Connection cables - KB100 terminal board

n.	Wire colour	KB100 terminal board	description
1	Red	+	Wire/Terminal "+" for the I-BUS connection
2	Yellow	D	Wire/Terminal "D" for the I-BUS connection
3	Green	S	Wire/Terminal "S" for the I-BUS connection
4	Black	-	Wire/Terminal "-" for the I-BUS connection
5	Blue	T1	Wire/terminal of keypad terminal T1
6	Black		Negative power wire/terminal (Negative or GND)

Table 12: Brackets - Description of parts

I	Wire entry
L	Wall-mount screw locations
M	Flush-mount screw locations
N	Backlocking grips

Mounting bracket

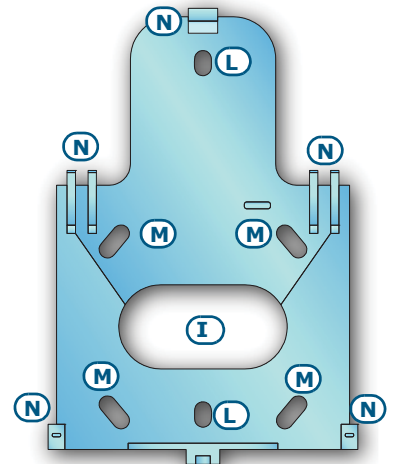

KB100 - deep mounting bracket

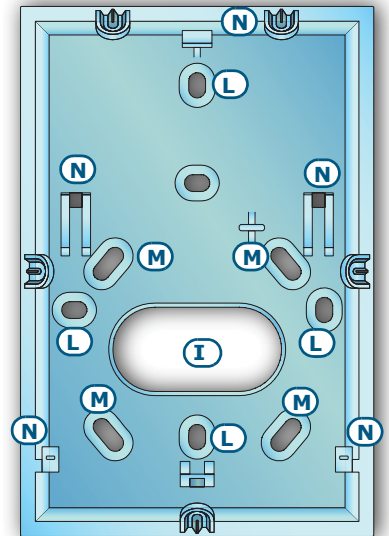

## Readers - nBy/S and nBy/X

Table 13: Device Specifications

	nBy/S	nBy/X
Voltage [V]	9 - 16	
Typical current draw [mA]	40	35
Dimensions (W x H x D) [mm]	64 x 80 x 17	19 x 50 x 51
Weight [g]	45	25

Table 14: nBy - Description of parts

A	Terminal board
B	Buzzer (nBy/S only)
C	LED
D	Antenna
E	Optical sensors for open-enclosure and dislodgement tamper detection

Reader terminals:

Table 15: nBy - terminal board

n.	Icon/ Identifier	description
1	+	Terminal "+" for the I-BUS connection
2	D	Terminal "D" for the I-BUS connection
3	S	Terminal "S" for the I-BUS connection
4	-	Terminal "-" for the I-BUS connection

## 2-3-3

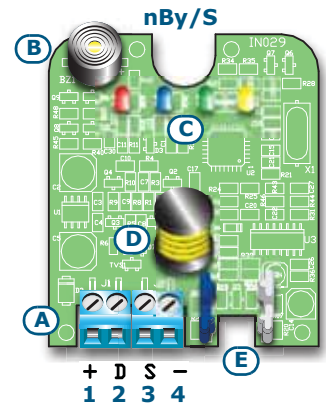

nBy/X

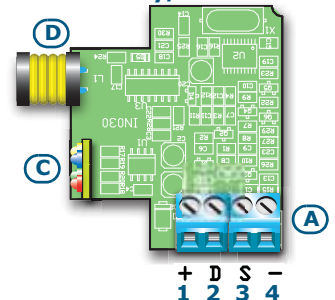

## Flex5 expansion boards 2-3-4

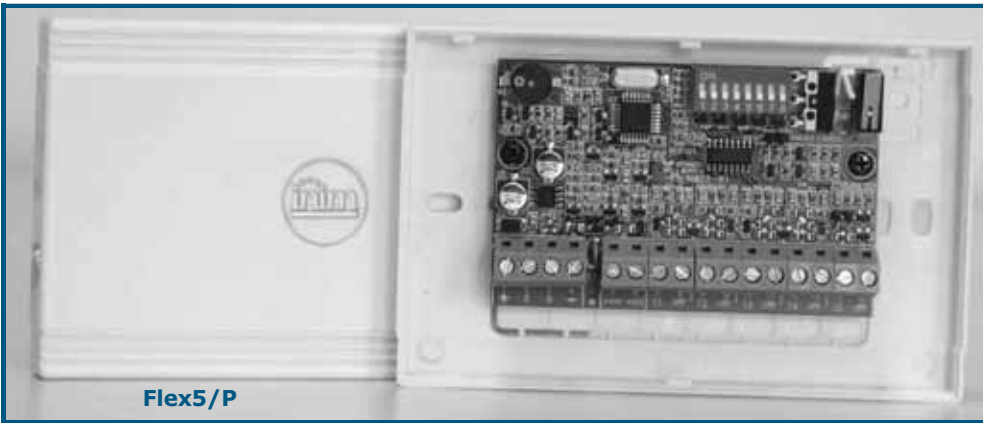

The Flex5 expansion board enclosure is available in two versions.

- **Flex5/P** comes in the enclosure shown above. This version can be set up to monitor dislodgement and open-enclosure tamper by inserting a jumper into connector [D], as shown.
- **Flex5/U** comes in an enclosure with on-view terminals and address DIP-Switch, as shown opposite. It is evident that this version offers little protection to the terminals. The jumper of connector [D] enables/disables the protection against open and dislodgement tamper of the plastic enclosure only.

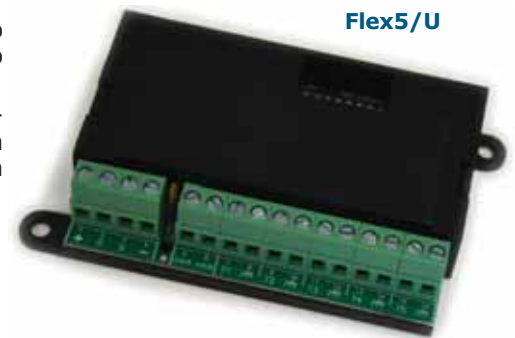

Table 16: **Device Specifications**

	FLEX5/P	FLEX5/U
<b>Voltage [V]</b>	9 - 16	
<b>Typical current draw [mA]</b>	30	
<b>Max. current across +AUX terminals [mA @13.8V]</b>	300	
<b>Dimensions including enclosure (W x H x D) [mm]</b>	125 x 79 x 26	105 x 58 x 18
<b>Weight including enclosure [g]</b>	103	66

The packages of both versions of the Flex5 expansion board contain:

- Flex5 expansion board in a plastic enclosure
- Dislodgement/Open tamper jumper
- 10 resistors @3K9Ω 1/4W
- 10 resistors @6K8Ω 1/4W

Table 17: **Flex5 - Description of parts**

<b>A</b>	Terminal board
<b>B</b>	Buzzer
<b>C</b>	DIP-Switch strip for peripheral device addressing
<b>D</b>	Connector to enable peripheral-tamper detection
<b>E</b>	Dislodgement tamper microswitch
<b>F</b>	Open-tamper microswitch
<b>G</b>	Peripheral activity LED (where present)

Peripheral activity LED signals are as follows:

- fast blinking - peripheral operative and enrolled (in configuration)
- slow blinking - peripheral operative but not enrolled (not in configuration)

The Flex5 expansion board terminals are as follows:

Table 18: **Expansion terminal board**

n.	Icon/ Identifier	description
<b>1-2-3-4</b>	<b>+ D S -</b>	I-BUS connection terminals
<b>5-6</b>	<b>+AUX</b>	12V ancillary power source terminals
<b>7-9-11-13-15</b>	<b>T1-T2-T3-T4-T5</b>	Screw terminals for expansion terminals: T1, T2, T3, T4 and T5
<b>8-10-12-14-16</b>		Negative power terminals (Negative or GND)

Terminals T1, T2, T3, T4 and T5 can be configured as:

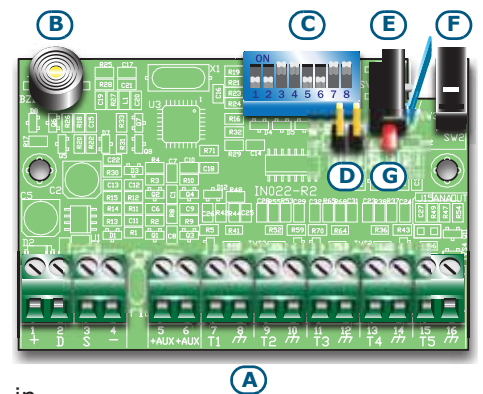



- Input (Rollerblind or Shock for terminals T1, T2, T3 and T4 only)
- Output
- Double zone
- Supervised Output

## **Transceiver for Air2-BS100 2-3-5**

The Air2-BS100 two-way wireless system integrates directly with all models of the INIM intrusion control panel range.

Description of the Air2 system devices:

- Air2-BS100 wireless transceiver module
- Air2-IR100 passive infrared detector
- Air2-MC100 magnetic contact/rollerblind/exit
- Air2-KF100 4 button remote-control keyfob

For a complete description of all these devices refer to the Air2-BS100 Installation Guide.

## **IVY sounder/flasher 2-3-6**

The self-powered sounders from the IVY outdoor series are controlled continuously by a microprocessor which monitors all the device parameters to ensure performance and reliability at all times.

For a complete description of all these devices refer to the sounder Installation Guide.

## **IB100 isolators 2-3-7**

Isolators from the IB100 series peripherals can be connected directly to the I-BUS, in order to increase both its length and performance.

Each isolator has 4 input terminals and 4 output terminals for the BUS connection with the following functions:

- Galvanic Isolation, up to 2500V, for the entire BUS between input and output.
- Regeneration of the communication signals.
- Detection of anomalies towards the output section and its consequent isolation.

For a complete description of all these devices refer to the respective Installation Guide.

## **Nexus dialers 2-3-8**

Nexus is the interface between SmartLiving control panels and the GSM communication channel managed by the control-panel BUS.

The functions made available to control panels equipped with this device are:

- voice calls via the Nexus using an installed SmartLogos30M voice board
- digital report calls via GSM using CONTACT-ID and ADEMCO 10 bps protocols
- SMS messages for each event using either -
  - the description provided by the keypad events log
  - the customized description (maximum 50 editable SMS texts)
- the control panel carries out commands sent by the user via SMS message
- the control panel carries out commands after recognition of the user's telephone number (CALLER-ID)
- Answerphone

Table 19: **Device Specifications**

<b>Voltage [V]</b>	9 - 16
<b>Current draw in standby [mA]</b>	90
<b>Maximum current draw [mA]</b>	900
<b>Dimensions including enclosure (W x H x D) [mm]</b>	105 x 58 x 18
<b>Weight including enclosure [g]</b>	66

The Nexus package includes:

- Nexus expansion board in a plastic enclosure
- Remote antenna with 3 meters of cable

Table 20: Nexus - description of parts

<b>A</b>	Terminal board
<b>B</b>	Antenna connector
<b>C</b>	P1 button
<b>D</b>	P2 button
<b>E</b>	SIM card housing (non included)
<b>F</b>	Buzzer
<b>G</b>	Open-tamper microswitch
<b>H</b>	Communication LED (green)
<b>I</b>	Emergency LED (red)
<b>L</b>	Fault LED (red)
<b>M</b>	Connection LED (green)

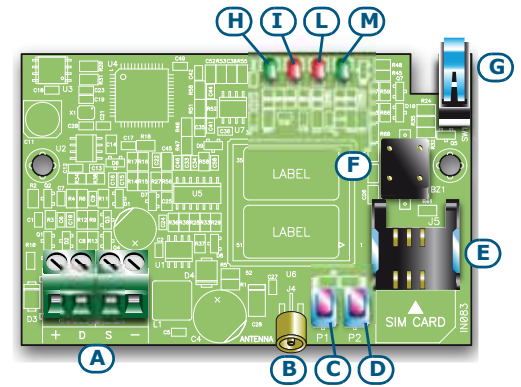

The terminals for the BUS connection are as follows:

Table 21: Nexus terminal board

n.	Icon/ Identifier	description
1	+	Terminal "+" for the I-BUS connection
2	D	Terminal "D" for the I-BUS connection
3	S	Terminal "S" for the I-BUS connection
4	-	Terminal "-" for the I-BUS connection

Peripheral activity LED signals are as follows:

Table 22: Nexus LEDs

LED	Function	ON	OFF
<b>Communication</b>	Indicates communication with the control panel	The LED blinks during ongoing communications	Not communicating
<b>Emergency</b>	Indicates communication failure with the control panel	Blinks in the event of tamper or fault on the BUS	Normal communication with the control panel
<b>Faults</b>	Indicates the presence of faults	Blinks in the event of ongoing faults	No faults present
<b>Connection</b>	Indicates the status of the GSM network	<ul style="list-style-type: none"> <li>Slow blinking - Searching for the provider</li> <li>Fast blinking - Provider found</li> </ul>	Device Off

After activation of the Fault LED (indicating a fault is present), you can obtain further information regarding the cause of the fault by simply pressing button P2 [D]. The successive activation of the Emergency and Fault signaling LEDs will signal as follows:

Table 23: Fault signaling

LED On	Fault
<b>Communication</b>	No Credit
<b>Emergency</b>	SIM card with PIN request enabled
<b>Faults</b>	Communication problems with the GSM module

You can obtain an indication of the GSM reception level by simply pressing button P1 [C] and observing the number of LEDs which light amongst the Communication, Emergency and the Fault LEDs (viewing lasts 5 seconds):

- 1 LED - weak reception
- 2 LED - good reception
- 3 LED - excellent reception

# Chapter 3

## INSTALLATION

### Installing the control panel

### 3-1

#### Wall-mounting

#### 3-1-1

The control panel should be located in a hidden place that can be accessed by authorized building occupants only.

- Using the backbox (Table 4: Control panels - description of parts, G), mark the anchor screw locations on the wall. Be sure not to drill in the vicinity of electrical wiring or plumbing/gas pipes, etc.
- Insert the screw anchors (recommended size 6mm).
- Pull the wires through the wire entry.
- Using the screws, attach the backbox to the wall.
- Fit the dislodgement-tamper microswitch (provided with SmartLiving 1050L and 10100L, optional for SmartLiving 505, 515 and 1050, refer to Appendix H, Order Codes, TamperNO).
  - Insert the dislodgement-tamper bracket [A] into its location on the backbox of the control panel (Table 4: Control panels - description of parts, H).
  - Using screw location [B], screw the bracket to the wall.
  - Connect the wire coming from the dislodgement-tamper microswitch [C] to the connector [D] on the board (Table 4: Control panels - description of parts, T).

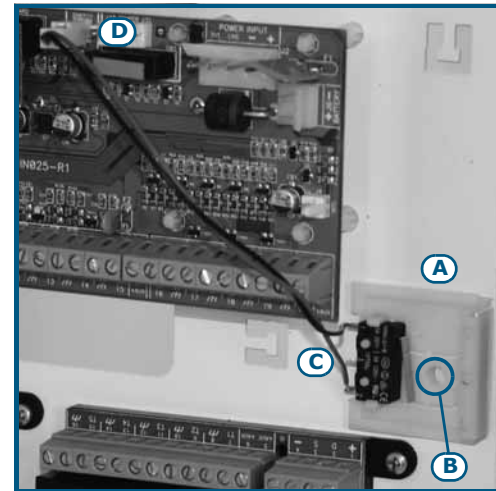

The sleeving must be flame class rating V-1 or higher.

#### Note

### Connecting the Mains power supply

### 3-1-2

The control panel must be powered through a separate line coming from the Mains box. The line must be protected by a safety-standards compliant circuit breaker (trip switch).

The circuit breaker (trip switch) must be located externally to the apparatus and should be easily accessible. The distance between contacts must be at least 3mm. The manufacturer strongly advises the use of a magnetothermic switch with C intervention curve and nominal (maximum) current - 16A.

The protective earthing system must be compliant with all safety standards and laws in force.

**Ensure that the Mains is switched Off during the mains connection phase. Danger of electric shock.**

#### DANGER!



#### The 505 and 515 models

Pull the mains (primary power-supply) cable through the cable entry [B], then complete the (Mains) connections on the mains terminal board [A]. When connecting the earth wire, follow the indications on the label [C] located near the mains terminal board. The transformer (located above the PCB) and switching power supply (housed inside the control panel enclosure) provide the power source to the entire system and supply the charge voltage to the backup battery.

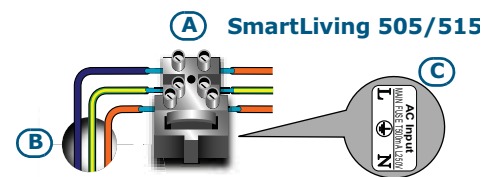

#### The 1050, 1050L and 10100L models

Pull the cable through the cable entry [E], then connect the mains power to the power-supply terminal board [D], located on the backplate above the motherboard. When connecting the earth wire, follow the indications on the power-supply label [F]. The power-supply provides power to the system and supplies the charge voltage.

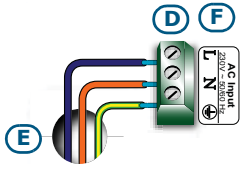

SmartLiving 1050

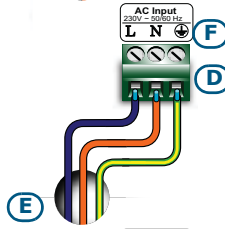

SmartLiving1050L

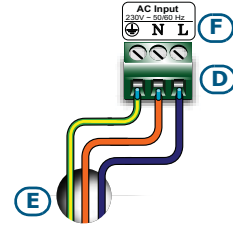

SmartLiving10100L

### Maximum current - normative references

Compliance with EN50131, CEI 79 or CEB T014 requires full observation of the rules (relating to the applicable normative and the model of the control panel concerned) presented in the Table below.

The system must be arranged in such a way that the current draw under normal circumstances does not exceed the maximum current allowed and the power source for the battery charge is always available.

Table 24: Maximum current permitted

Norm		SmartLiving intrusion control panels				
		505	515	1050	1050L	10100L
EN50131-3	Maximum current permitted	1.2A	1.2A	2.6A	3A	3.5A
	Current reserved for the battery charge	1A	1A	2A	2A	2A
CEI 79-2	Maximum current permitted	1.2A	1.2A	2.6A	3A	3.5A
	Current reserved for the battery charge	1A	1A	2A	2A	2A
CEB T014	Maximum current permitted	1.2A	1.2A	2.3A	2.7A	2.7A
	Current reserved for the battery charge	1A	1A	2A	2A	2A

### Connecting the backup battery

The backup battery [A] connection must be completed during the phase described in Chapter 4 - First power up.

The SmartLiving 505, 515 and 1050 control panels house one lead battery @12V 7Ah.

The SmartLiving 1050L and 10100L house two lead batteries, one @12V 17Ah and the other @12V 1.2Ah.

The battery casing must have HB flame rating or higher.

Using the battery wire [B] (included), connect the battery directly to the control panel motherboard.

**Ensure that battery polarity is correct:**

- black wire = negative
- red wire = positive

The backup battery is the secondary power source which powers the system during mains failure (230Vac, 50Hz).

Once powered up, the panel will charge and monitor the batteries automatically. The panel tests the efficiency of the batteries by simulating load current demand at regular 4 minute intervals. If the control panel detects a voltage inferior to 10.4V (battery inefficient), it will generate an Empty battery event that will not clear until the voltage goes back to over 11.4V.

This fault will be signaled on the yellow LED on the keypads. To view the event details, work through the following steps:

Type-in Code (User) **OK**, View **OK**, Faults **OK**.

### 3-1-3

### 3-1-4

**Note**

**ATTENTION!**



SmartLiving 505/515

SmartLiving 1050

SmartLiving10100L

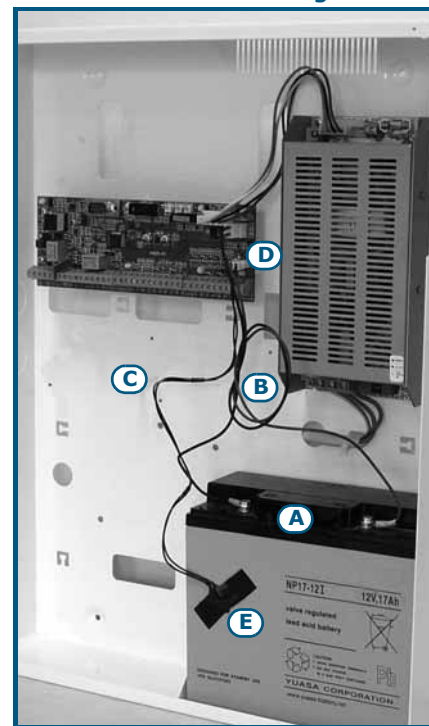
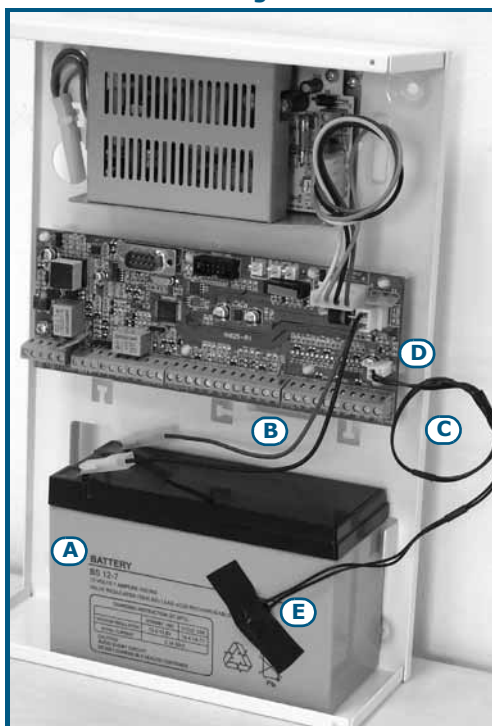
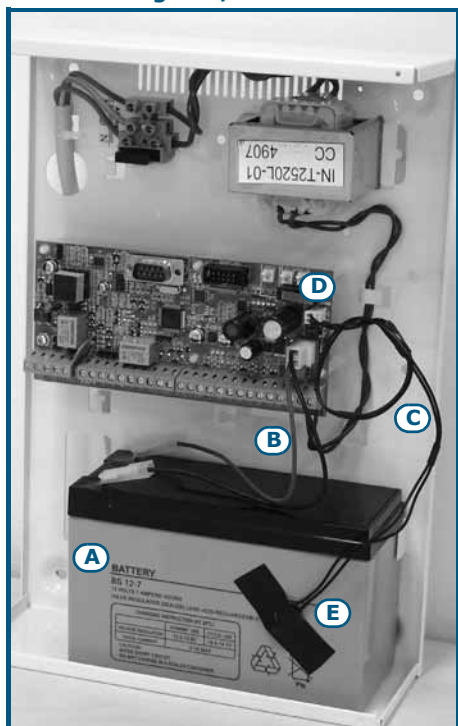

### Thermal Probe

### 3-1-5

The battery charge process can be optimized by means of a thermal probe [C] (accessory item). This device regulates the charging process in accordance with the battery temperature. The thermal probe protects against battery overheating and consequent permanent damage to the battery.

To connect a thermal probe, work through the following steps.

1. Disconnect the battery (if necessary).
2. Connect the thermal probe to the connector on the board [D]. If you are installing a model which is equipped with a switching power supply (Smart-Living 1050, 1050L and 10100L), you can connect the thermal probe directly to the power supply connector.
3. If you are installing a SmartLiving505 or 515 model, remove the jumper on the motherboard to enable the thermal probe (refer to *Table 4: Control panels - description of parts, N*).
4. Using adhesive-insulating tape, attach the thermal probe to the battery [E], in such way as to provide optimized heat-transfer measurements.
5. Hold a thermometer against the probe, and measure the probe temperature.
6. Using the following graph, find the value the measurement will be based on.

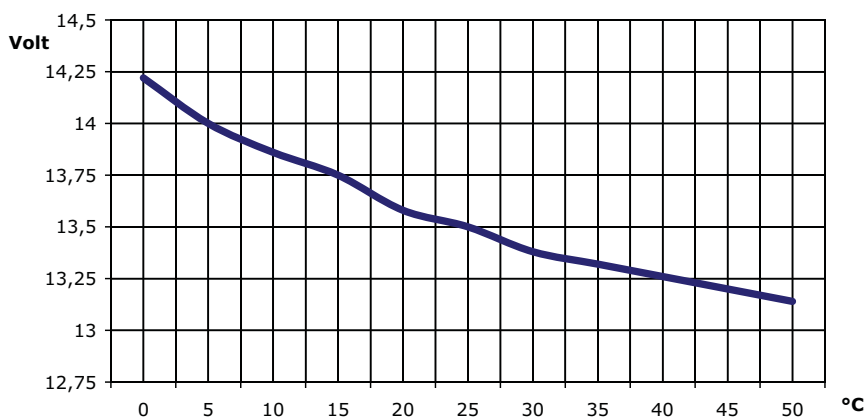

7. Using a tester, measure the voltage on the +AUX terminals and adjust the trimmer [F] to the previously measured value.

3A switching power supply

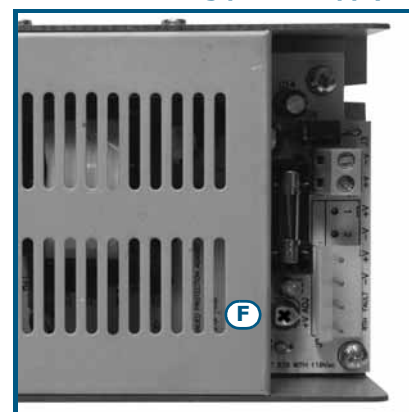

5A switching power supply

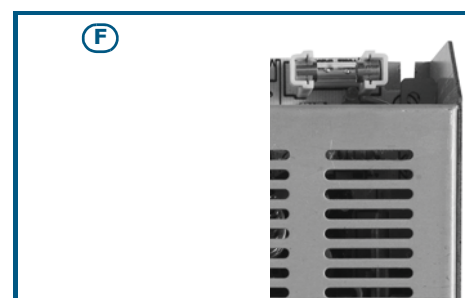

## Opening and closing the control panel

### 3-1-6

If you wish to remove the metal frontplate, work carefully through the following steps.

1. Type-in the installer code and press **OK**. Access to the installer menu inhibits the alarm outputs and dialer automatically, therefore, the system will be unable to generate alarms or event calls.
2. Remove the four screws and the metal-frontplate.
3. Insert the Service jumper (refer to paragraph 3-1-10 *Maintenance status*) and carry out the necessary work.

Once your task is complete, work carefully through the following steps.

1. Remove the Service jumper.
2. Using the 4 screws, secure the frontplate to the backbox.
3. Exit the installer menu.

If you exit the Installer menu before replacing the panel frontplate, the system panel will not generate an "Open-panel" event.

However, the system will generate an "OpenPanel" event, if the frontplate is not replaced within 15 seconds of closing the open-tamper microswitch.

### Note

## Land-line connection (PSTN)

### 3-1-7

Terminals 4 and 5 on the control panel motherboard (*Table 5: Control panel - terminal board, 4-5*) are for the land-line telephone connection.

In order to protect the control panel from lightning, you should use two 150Vrms varistors (supplied); they must be connected between the earth terminal 1 and PSTN terminals 4 and 5 on the control panel terminal board.

If you are installing the system in a place where the land line (PSTN) service is not available, or if you wish to increase the level of security of the system, these terminals also accept a GSM interface (such as Inim's SMARTLINK) which simulates the analogue land-line.

Inim manufactures two versions of the SMARTLINK GSM Interface: SMARTLINKG and SMARTLINKGP. Both these devices simulate the analogue land line during line-down conditions (line trouble or wire-cutting) and allow the control panel to switch incoming/outgoing calls to the GSM network.

You can also use the terminals on the SmartLink board to extend the functions provided by the SmartLiving system. The following section describes several methods which will allow you to provide users with advanced functions.

### Arming/Disarming the system over-the-phone using a cost-free call or SMS text

If you connect one of the SmartLiving board terminals, which is configured as a "follow zone", to an output on the SmartLink board, users will be able to arm or disarm ("ARM ON" or "DISARM OFF") the SmartLiving system by sending an SMS text (refer to paragraph 3.12 in the SmartLink programming manual).

In a similar way, using a "switch zone", users will be able to arm or disarm the system by calling the control panel (refer to "Caller ID" in paragraph 3.9 in the SmartLink programming manual).

### Alarm warning to users via SMS text

If you connect one of the control-panel alarm outputs to an input on the SmartLink board, the system will be able to send users alarm warnings via SMS text (refer to paragraph 3.10 in the SmartLink programming manual). The system can be set up to send an editable SMS text to 10 different contact numbers.

All the functions of the SmartLiving system which use the land line (voice dialer, answerphone, report communications and teleservice) can be managed completely over the GSM network by the SmartLink. The SmartLink will also allow you to carry out teleservice maintenance over the GSM network.

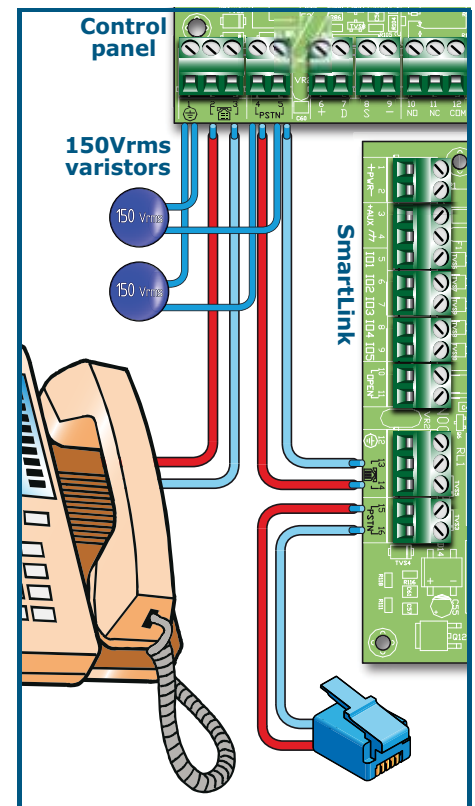

### Note

If there is ADSL line, it will be necessary to connect the control panel downstream of the ADSL filters, to the line dedicated to telephone equipment (this line is clearly indicated on the filters).

### Connecting to a PC

### 3-1-8

Programming from a PC requires the SmartLeague software programme (refer to paragraph 6-3 *Programming via the SmartLeague programme*) and an RS232 serial cable.

Insert the RS232 serial link (accessory item) into the connector [A], as shown in the figure opposite.

If you wish to purchase an RS232 serial link, refer to the codes in *Appendix H, Order Codes*. If your PC is not equipped with an RS232 port, but has a USB instead, you can use INIM's Approved RS232-USB adaptor (accessory item).

SmartLiving end DB9F connector		PC end DB9F connector	
	2	3	
	3	2	
	4	4	
	5	5	
	6	6	
	7	7	
	8	8	

SmartLiving end DB9F connector		PC end DB25F connector	
	2	2	
	3	3	
	4	20	
	5	7	
	6	6	
	7	4	
	8	5	

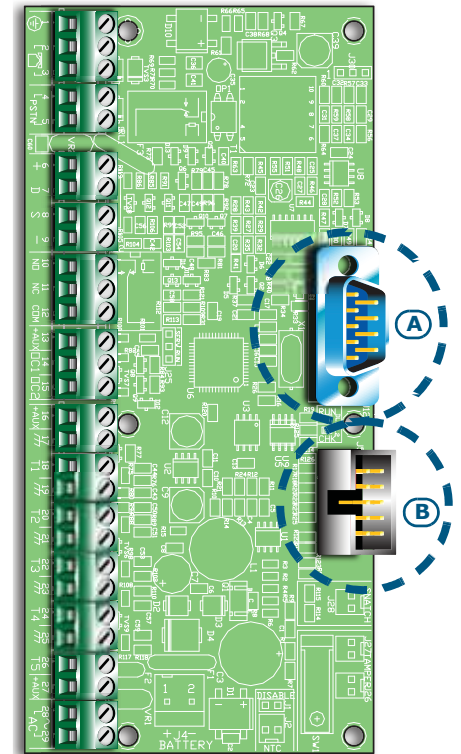

### Connecting the SmartLogos30M voice board (accessory item)

### 3-1-9

The SmartLogos30M voice board provides the SmartLiving system with an array of useful voice functions.

For proper installation of the board, work carefully through the following steps.

1. Disconnect all power sources to the control panel (mains and lead batteries).
2. Connect the board to the respective connector [B].
3. Power up the system from the mains and reconnect the lead batteries.

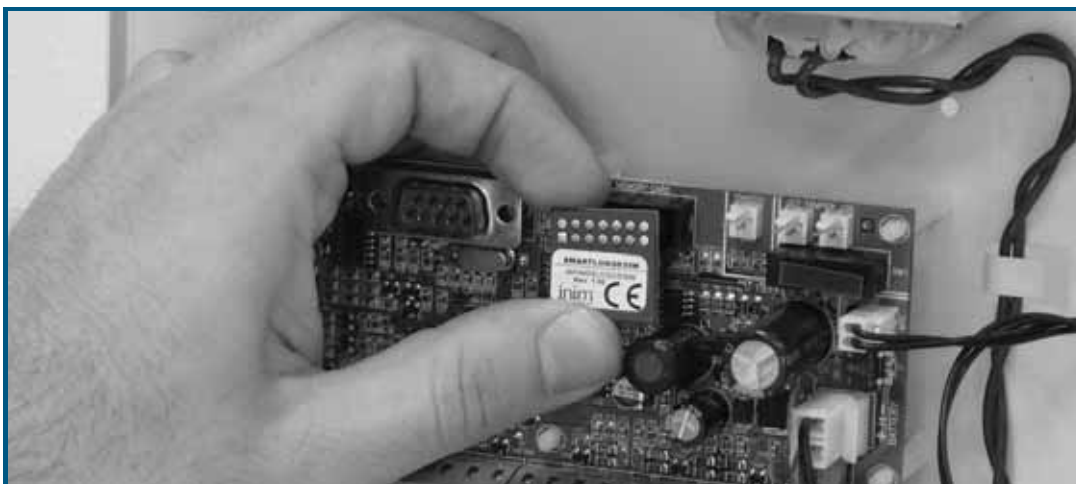

## Maintenance status

There are two distinct positions for the Service jumper (Table 4: Control panels - description of parts, Q):

1. "RUN" (control panel operating normally)
2. "SERV" (control panel ready for maintenance work)

The keypads indicate maintenance status (jumper in "SERV" position) by showing the "Maintenance" message on the first line on the display next to the keypad address. The address of the built-in reader (if enabled) of JOY/MAX keypads will also be shown.

Under these circumstances, the control panel:

- Forces the relay output on the motherboard (Table 5: Control panel - terminal board, 10-11-12) to standby status.
- Does not activate the outputs (and will force to standby any active outputs) triggered by:
  - alarm or zone/partition tamper
  - peripheral tamper
  - open/dislodged panel tamper
- It allows initialization of the keypad address programming phase.
- It allows initialization of the reader address programming phase.
- It initializes automatically the auto-enrolment of the peripherals connected to the BUS at 10 seconds intervals. It allows assignment of the addresses to the peripherals connected to the BUS and, at 10 second intervals, enrolls the peripherals it finds.
- The control panel will not reset the BUS in an attempt to retrieve peripherals in the event of peripheral loss.
- It will continue to operate as normal, except under the aforesaid circumstances.

### 3-1-10

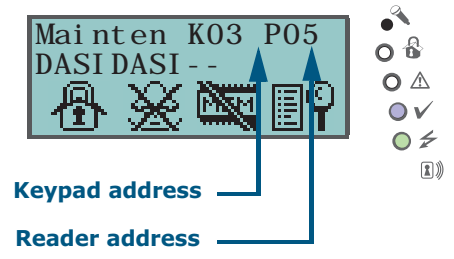
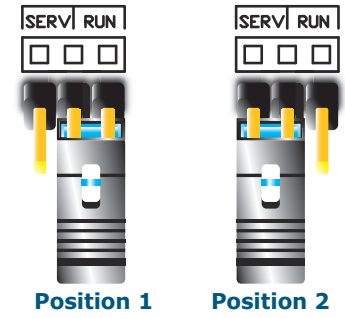

## Connecting peripherals

### The I-BUS line wiring

The SmartLiving peripherals (keypads, readers, expansions, sounderflashers, transceivers, isolators and GSM communicator) must be connected to the control panel via the I-BUS.

The wiring diagram opposite provides an example of a 4-wire connection (using shielded cable) between a control panel and its peripherals.

The cable specifications depend on the length of the BUS (from the panel terminals to the most distant point), Baud rate and the load current draw.

Table 25: Recommended cable

Cable AF CEI 20-22 II	n. wires	Section (mm <sup>2</sup> )	I-BUS terminal
4 wire cable + shield	2	0.5	+ -
	2	0.22	D S
6 wire cable + shield	2	0.5	+ -
	2	0.22	D S
	2	0.22	available
6 wire cable + shield	2	0.75	+ -
	2	0.22	D S
	2	0.22	available

The maximum wire length of the I-BUS depends on the deployment of the peripherals connected to the line and their specific current draw (in particular the keypads and expansion boards). The power to peripherals and detectors can be supplied by external power stations or by the line itself.

Furthermore, the speed of the communication BUS (Baud rate) can be modified by means of the SmartLeague programming software. If the BUS is not used to power the peripherals and their loads, the maximum wire length is 300 meters @ 250kbs, regardless of the number of peripherals involved.

An intermediate speed (125kbs) can support a single section of 700 meters.

### 3-2

#### 3-2-1

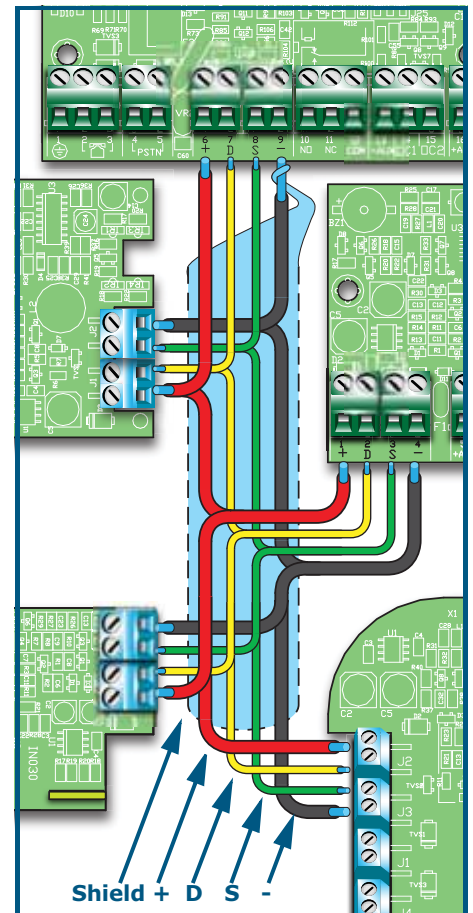



**The shield must be connected to one of the  $\text{///}$  terminals (Negative or GND) at the control panel end only, and must run along the BUS without being connected to negative or GND at any other point.**

**ATTENTION!**

If you wish to increase the length and performance of the BUS, you can connect IB100 isolators .

If the speed of the communication BUS (Baud rate) is low (38.4 or 125 kbps), you can apply a maximum of 5 isolators in a cascade connection.

If the speed of the communication BUS (Baud rate) is high (250 or 2 kbps), you can apply a maximum of 2 isolators in a cascade connection.

You can connect up to 15 isolators in all.

**It is extremely important to evaluate correctly the number of isolators connected in cascade to the BUS.**

**ATTENTION!**

The following example will help you achieve a correct evaluation:

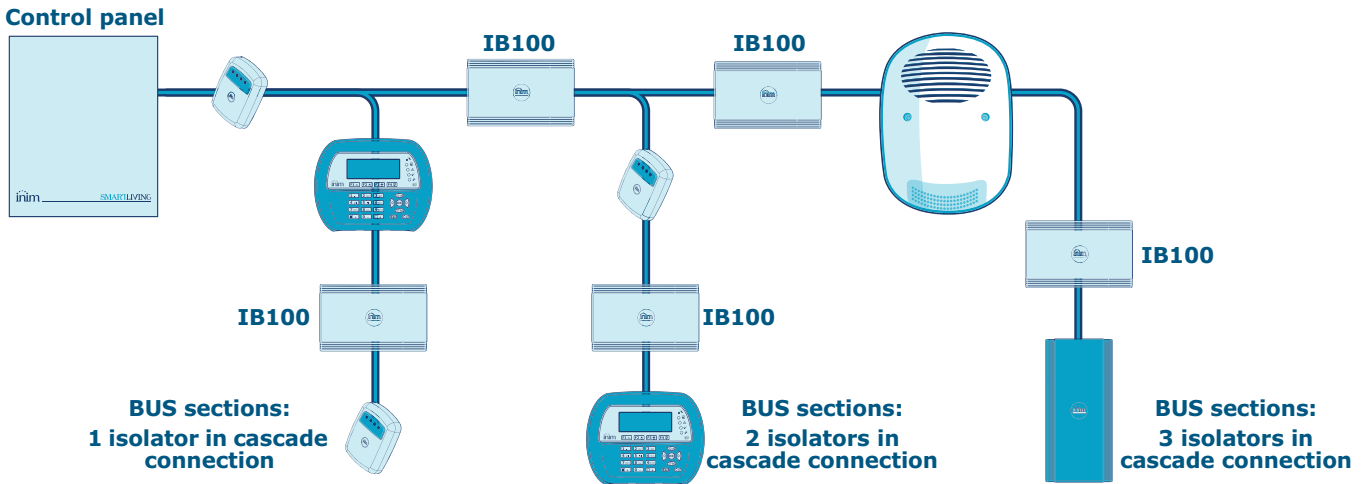

### Installing JOY keypads

### 3-2-2

1. Remove the keypad from its package.
2. Detach the down-flip and cover from the backplate.
3. Remove the board from the backplate. Be careful not to damage the dislodgement-tamper spring [A] during this operation.
4. Mark the chosen anchor-screw locations [B] on the wall. Use at least 2 of the 7 locations available. Drill the anchor-screw holes (ensure that you do not drill in the vicinity of electrical wiring or plumbing). Pull the BUS and terminal connection wires through the wire entry [C] and attach the backplate securely to the wall.
5. Using the screw, fasten the dislodgement-tamper bracket into its screw location [D].
6. For JOY/MAX only: Plug the speaker connector [E] into the keypad circuit, ensure that polarity is correct (black wire to the right [F] and red wire to the left [G]). Be careful not to damage the connector during this operation. If it becomes necessary to separate the connector from the speaker, use a small screwdriver or similar tool to disengage it. DO NOT pull the connector out by the wires.

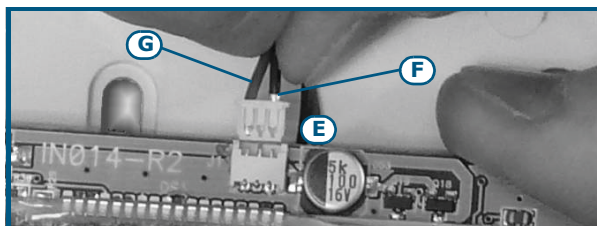
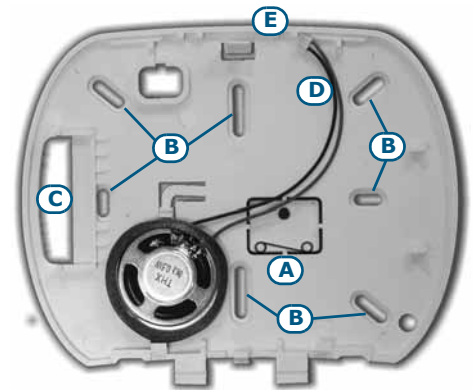

7. Place the circuit on the two lower supports [H] and, after aligning it with the other supports [I], push the back-locking grip [J] slightly outwards until it clicks closed. Be careful not to damage the dislodgement-tamper spring [A].
8. Replace the cover and down-flip. If necessary, secure the two screws into their screw locations on the bottom part of the cover.

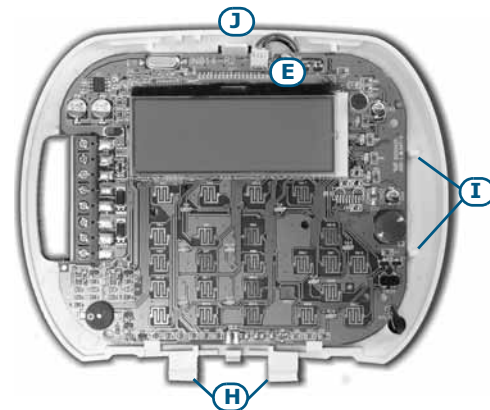

### Installing nCode/G and Concept/G keypads

### 3-2-3

1. Connecting the device to the system
2. Pull the connection wires through the wire entry [A].
3. Connect the cables to the connector on the keypad backplate [B]. If you are using the connector provided with the KB100 kit [C], connect the wires to the terminals, in accordance with the instructions described in paragraph 2-3-2 *nCode/G and Concept/G Keypads*, then insert the connector into the guide [D] until it locks into place.
4. Using at least 2 screws, mount the bracket to the wall.
5. Using the back-locking grips, attach the keypad to the bracket (as shown in figure [E]).
6. Fasten the screw [F] (included) into the screw location [G], to secure the keypad properly to the bracket.

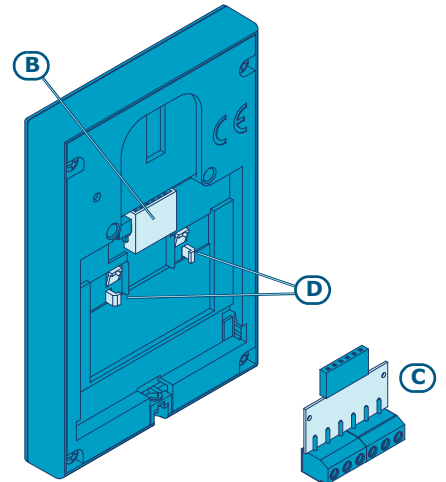
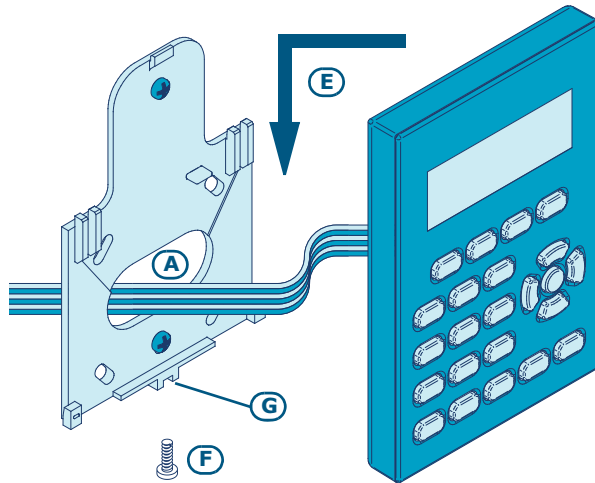

### Installing nBy/S readers

### 3-2-4

The wall-mount nBy/S reader is suitable for indoor and outdoor installation. Insert the two anchor screws [A] (included) into the two screw locations [B] on the plastic backplate.

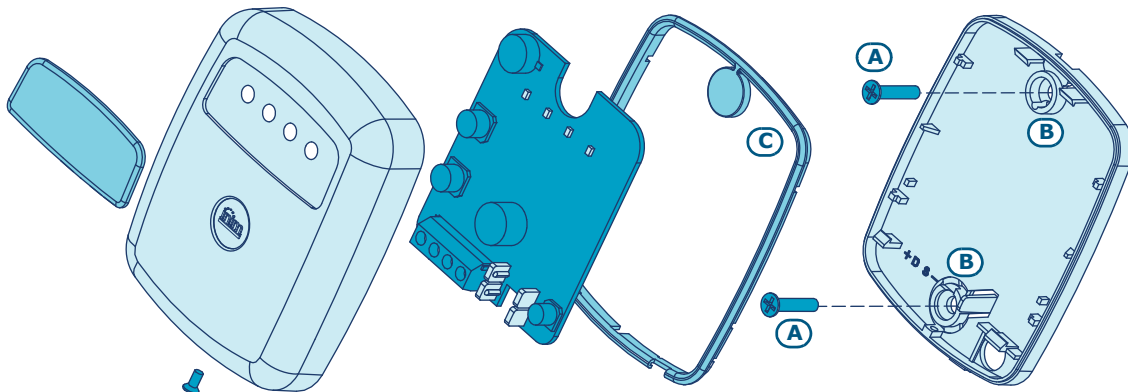

**In order to avoid the risk of piercing the silicone seal [C], and thus jeopardizing the waterproofing of the enclosure, insert the screws before fitting the seal.**

**ATTENTION!**

### Installing nBy/X readers

### 3-2-5

The Universal flush-mount nBy/X (**Patent Pending**) has been especially designed to integrate with all brands of cover plates [A]. Drill two holes [B] for the light guide [C].

Use the adhesive drill-pattern (see opposite) to mark the drilling locations accurately.

1. Ensure that the centre of the cover plate coincides with the crossing of the axes x and y on the drill-pattern. In this way, the two drilling locations (1 x 7mm diameter and 1 x 8mm diameter) will be positioned precisely.
2. Using the screw [D], secure the reader components inside the cover plate.
3. Insert the cover plate (with the reader already assembled) into the light switch box.

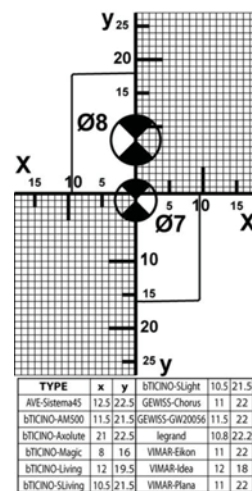
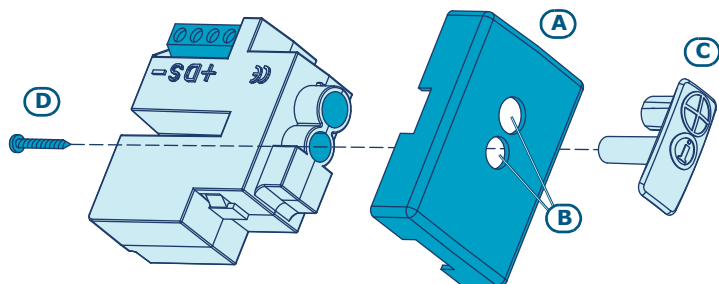

### Dislodgement tamper

The nBy/X reader is not equipped with built-in dislodgement-tamper protection. However, the following section describes how you can protect nBy/X reader against this kind of tamper.

In order to comply with Italian certification (Level 2 - IMQ Security Systems), all the system peripherals must be protected against tamper. Installation of a microswitch will allow the reader to signal tamper events. To obtain this type of protection, work carefully through the following steps.

1. Use a microswitch with at least two normally-open contacts [A]. The one shown in figure 3 has 3 contacts: COM-NO-NC.
2. Configure one of the terminals as follows: Input; 24H; Description = "Tamper reader x"; single balancing with 6k8Ω [resistance [B]; unlimited alarm cycles. Assign the duly programmed terminal to at least one keypad partition.
3. Using 2 wires, connect the microswitch to the 24H input terminal.
4. On the microswitch:
  - 4.1. using one of the two wires, connect the common contact (COM) to the GND terminal of the 24H terminal [C].
  - 4.2. Connect the normally-open contact (NO) to one end of the 6k8Ω resistance [D] (the normally-open contact generates a short-circuit between itself and the COM contact when the microswitch-lever is compressed). Connect the other end of the resistance to the wire which is connected to the 24h input terminal.
5. Install the microswitch as shown in the previous figure, so that the switch lever is compressed. If an unauthorized attempt to dismantle the nBy/X reader occurs, the lever will expand in order to open the contact which triggers instant alarms on the 24H terminal.

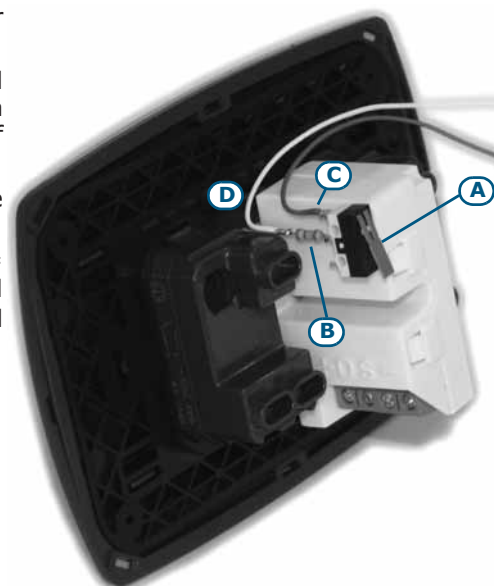

This wiring method can be applied in most situations, however, it is only a point of reference. In order to ensure proper protection, you must always take in to account the specific mechanical and electrical conditions of the device you are working on.

**In order to avoid malfunction, it is advisable not to install nBy/X readers onto metal plates.**

### Note

**ATTENTION!**

## Installing the Nexus

**3-2-6**

In order to allow this device to function properly, you must install it in a safe, dry place which provides the best possible GSM reception.

### Disable the SIM card PIN.

**ATTENTION!**

1. Ensure that the Nexus is not powered-up.
2. Insert the SIM card into its housing (refer to *Table 20: Nexus - description of parts, E*).
3. Install the antenna and connect it to the respective input (refer to *Table 20: Nexus - description of parts, B*).
4. Connect the BUS to the terminal board (refer to *Table 20: Nexus - description of parts, A*).

# Addressing the peripherals 3-3

In order to allow the control panel to identify the peripherals distinctly, you must assign a different address to each device. However, you can assign the same address to two devices which belong to different categories (e.g. a Flex5 expansion and a JOY keypad) as, in this case, the control panels will see them as two distinct devices.

Expansion - Transceiver address		DIP-switch	Reader address	Red	Blue	Green	Yellow	nBy/S	nBy/X	Keypad address
SmartLiving505	1	00000000	1	0	0	0	1	○ ○ ○ ●	⊕	1
	2	00000001	2	0	0	1	0	○ ○ ● ○	⊕	
	3	00000010	3	0	0	1	1	○ ○ ● ●	⊕	
	4	00000011	4	0	1	0	0	○ ● ○ ○	⊕	
	5	00000100	5	0	1	0	1	○ ● ○ ●	⊕	
	6	00000101	6	0	1	1	0	○ ● ● ○	⊕	
	7	00000110	7	0	1	1	1	○ ● ● ●	⊕	
	8	00000111	8	1	0	0	0	● ○ ○ ○	⊕	
	9	00001000	9	1	0	0	1	● ○ ○ ●	⊕	
	10	00001001	10	1	0	1	0	● ○ ● ○	⊕	
SmartLiving515 and 515	11	00001010	11	1	0	1	1	● ○ ● ●	⊕	2
	12	00001011	12	1	1	0	0	● ● ○ ○	⊕	
	13	00001100	13	1	1	0	1	● ● ○ ●	⊕	
	14	00001101	14	1	1	1	0	● ● ● ○	⊕	
	15	00001110	15	1	1	1	1	● ● ● ●	⊕	
	16	00001111	16	0	0	0	L	○ ○ ○ ⊗	⊕	
	17	00010000	17	0	0	L	0	○ ○ ⊗ ○	⊕	
	18	00010001	18	0	0	L	L	○ ○ ⊗ ⊗	⊕	
	19	00010010	19	0	L	0	0	○ ⊗ ○ ○	⊕	
	20	00010011	20	0	L	0	L	○ ⊗ ○ ⊗	⊕	
SmartLiving1050 and 1050L	21	00010100	21	0	L	L	0	○ ⊗ ⊗ ○	⊕	3
	22	00010101	22	0	L	L	L	○ ⊗ ⊗ ⊗	⊕	
	23	00010110	23	L	0	0	0	⊗ ○ ○ ○	⊕	
	24	00010111	24	L	0	0	L	⊗ ○ ○ ⊗	⊕	
	25	00011000	25	L	0	L	0	⊗ ○ ⊗ ○	⊕	
	26	00011001	26	L	0	L	L	⊗ ○ ⊗ ⊗	⊕	
	27	00011010	27	L	L	0	0	⊗ ⊗ ○ ○	⊕	
	28	00011011	28	L	L	0	L	⊗ ⊗ ○ ⊗	⊕	
	29	00011100	29	L	L	L	0	⊗ ⊗ ⊗ ○	⊕	
	30	00011101	30	L	L	L	L	⊗ ⊗ ⊗ ⊗	⊕	
SmartLiving10100L	31	00011110								4
	32	00011111								
	33	00100000								
	34	00100001								
	35	00100010								
	36	00100011								
	37	00100100								
	38	00100101								
	39	00100110								
	40	00100111								

0	○	LED OFF
1	●	LED ON
L	⊗	LED blinking

You must not exceed the maximum number of addresses allowed for each type of peripheral. The following table shows the available peripheral addresses and the maximum number of addresses accepted.

The top left section of the Table shows the maximum number of addresses (5 for the SmartLiving505 model, 10 for the 515 model, 20 for the 1050 model and 40 for the 10100 model) and the DIP-switch configuration paragraph 3-3-2 Addressing FLEX5 expansions and the Air2-BS100 transceiver of the Flex5 expansion board and Air2-BS100 transceiver (refer to ).

The second section shows the nBy/S and nBy/X reader addresses with the corresponding combination of the reader LEDs (refer to paragraph 3-3-3 Addressing nBy readers).

The section on the far right shows the addresses available for the keypads (refer to paragraph 3-3-1 Addressing the keypads).

For the Ivy sounderflasher and IB100 isolator addressing procedure, refer to the respective Installation Guides.

It is possible to connect only one Nexus device to the SmartLiving control panels, therefore, there no addressing procedure is required.

## Addressing the keypads

Work carefully through the following steps.

1. Put the control panel in "Maintenance" mode by inserting the respective jumper (Table 4: Control panels - description of parts, Q).
2. Using the keypad you wish to address, press and release keys **1 .,** and **3 def** simultaneously; set the address then press **OK** (if the keypad firmware version is 1.02 or higher, go to point 5).
3. For JOY/MAX only: enable or disable the reader press keys **1 .,** or **2 abc**.
4. For JOY/MAX only: if the reader is enabled, assign the address and press **OK**.
5. If the keypad firmware version is 1.02 or higher, enable or disable the dislodgement tamper protection by pressing **1 .,** or **2 abc**.
6. If the keypad firmware version is 1.08 or higher, enable or disable the dislodgement tamper protection by pressing **1 .,** or **2 abc**.

For security reasons, if the address is not assigned within 30 minutes of accessing "Maintenance" mode (SERV jumper inserted), the keypad will exit the programming phase automatically.

If this occurs and you wish to restart the programming phase, remove and re-insert the jumper.

The same procedure is necessary when you re-address the keypad.

### 3-3-1

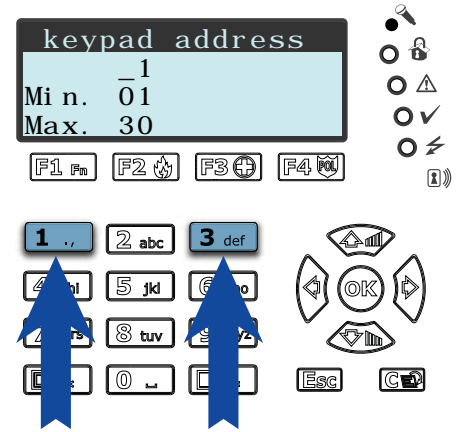

**Note**

## Addressing FLEX5 expansions and the Air2-BS100 transceiver

Using a small screwdriver or similar tool, set the expansion board address on the 8-segment DIP-Switch strip (Table 17: Flex5 - Description of parts, C). Each segment can be set at "1" (On) or "0" (Off).

The figure shows some examples.

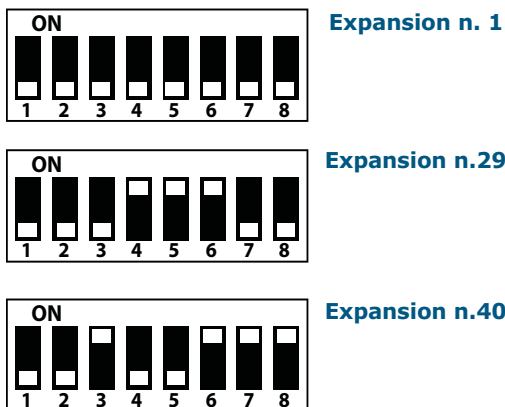

### 3-3-2

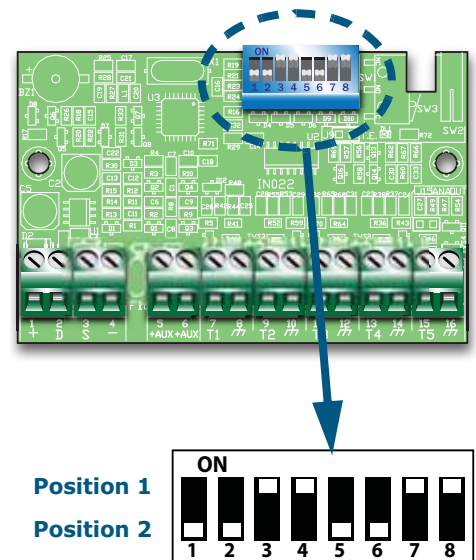

## Addressing nBy readers

To assign addresses to the system readers, work carefully through the following steps.

1. Put the control panel in "Maintenance" mode by inserting the respective jumper (Table 4: Control panels - description of parts, Q).
2. Start the "Address Programming" phase using the software or from a keypad:

Type-in Code (Installer PIN) **OK**, PROGRAMMING Readers **OK**, Prog. address **OK**.

3. Each reader indicates its own address on its LEDs (refer to the Table in paragraph 3-3 Addressing the peripherals).
4. Hold a valid key in the vicinity of the reader. The reader will run through a series of available reader-addresses (an address every 2 seconds). Remove the key when the LEDs indicate the desired address.
5. The reader will hold the addressing phase for a further 10 seconds, in order to allow you to change the address if necessary.
6. The reader will assign the selected address when the 10 second period expires.

### 3-3-3

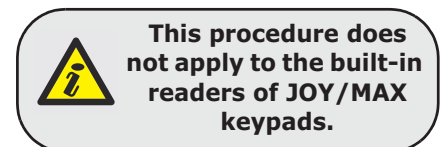

7. If you wish to assign an address to another reader, hold a valid key in the vicinity of the reader and work through points 4 to 6.
8. End the reader-address programming phase (exit "Prog. address" via keypad, or click on "Stop reader address setup", if you are using the SmartLeague software).

## Auto-enrolling peripherals 3-4

The peripherals connected to the BUS are enrolled automatically in the following situations:

- on first startup (refer to *Chapter 4 - First power up*)
- if the SERV jumper is inserted (refer to paragraph 3-1-10 *Maintenance status*)
- via the Installer menu (refer to paragraph 6-23 *Default settings*) >

Type in Code (Installer) **OK**, PROGRAMMING Default settings **OK**, Auto Periph **OK**.

## Wiring and balancing alarm detectors 3-5

The wiring and respective balancing method depend on the type of detector you are installing, and the level of protection you wish to achieve. The detectors can be powered through:

- terminals [+AUX/12V] and [-/GND] on the control panel
- terminals [+AUX/12V] and [-/GND] on FLEX5 expansions
- terminal [+12V] and terminals [-/GND] on keypads
- from any 12V ancillary source on condition that its GND reference is in common with that of the control panel.

The resistors used for balancing are:

- 3K9Ω 1/4W
- 6K8Ω 1/4W

The following Table indicates the protection level of each detector type and the balancing options provided by the control panel:

Table 26: **Protection level**

BALANCING	N.O.	N.C.	Single	Double	Double zone	Double zone with EOL
<b>Infrared or Double technology</b>	very low	low	medium (*)	high	medium	high
<b>Magnetic contact</b>	very low	low	medium		medium	high

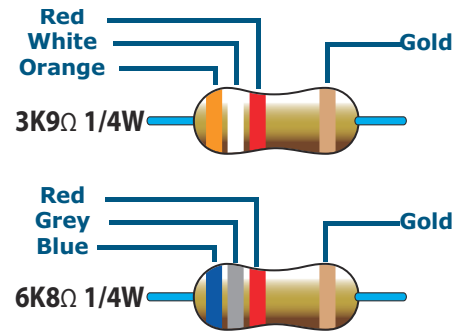

**(\*) Single balancing provides the same level of protection as Double balancing, when the tamper contact of the detector is connected to a balanced zone on the control panel.**

## N.C./N.O. Balancing 3-5-1

For N.C. (normally closed) and N.O. balancing (normally open), it is possible to detect two distinct zone conditions:

- standby
- alarm

For each of these, the control panel reads different resistance values on the terminal, expressed below in Ohm.

Ω	N.C.	N.O.
> 2 x 3900 + 6800	alarm	standby
> 2 x 3900 + 6800	alarm	standby
3900 + 6800	alarm	alarm
2 x 3900	alarm	alarm
3900	standby	alarm
0	standby	alarm

If you wish the detector to signal tamper events, connect the detector "Tamper" terminal to a "24h" zone on the control panel.

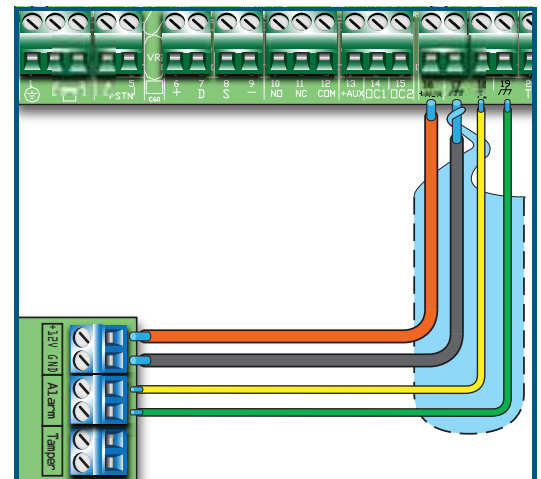

## Single balancing 3-5-2

Single zones can discriminate 3 conditions on the entire terminal:

- standby
- alarm
- tamper (short-circuit)

For each of these, the control panel reads different resistance values on the terminal, expressed below in Ohm.

$\Omega$	Zone
> 6800	alarm
6800	standby
0	tamper

If you wish the detector to signal tamper events, connect the detector "Tamper" terminal to a "24h" zone on the control panel.

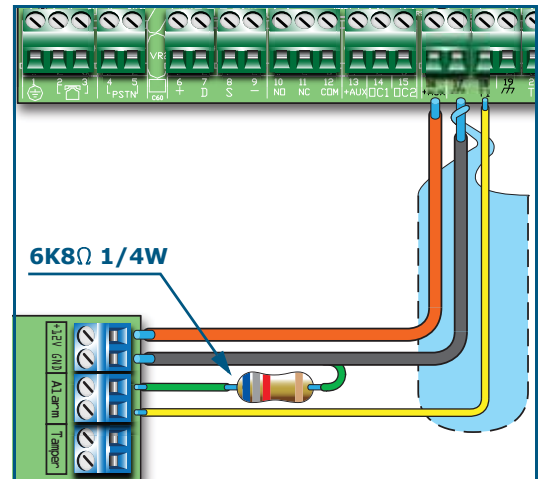

## Double balancing 3-5-3

Double balancing discriminates 4 distinct conditions on the zone terminal:

- standby
- alarm
- tamper (short-circuit)
- tamper (wire cutting)

For each of these, the control panel reads different resistance values on the terminal, expressed below in Ohm.

$\Omega$	Zone
> 6800	tamper (wire cutting)
6800	alarm
6800 / 2	standby
0	tamper (short-circuit)

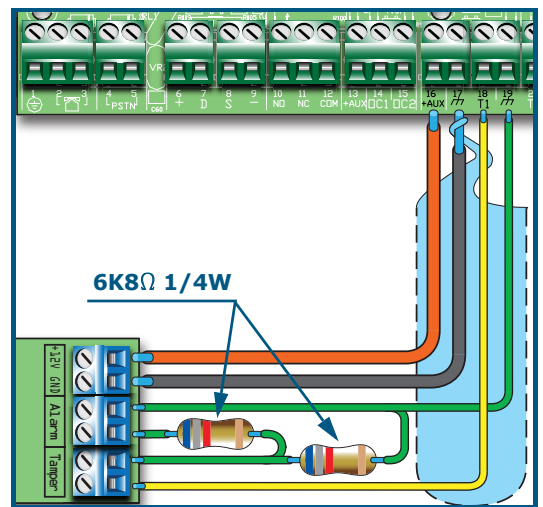

## Double-Zone balancing 3-5-4

Double zones without EOL resistor can discriminate 5 conditions on the entire terminal:

- standby on both zones
- alarm on zone 1 and standby on zone 2
- alarm on zone 2 and standby on zone 1
- alarm on both zones
- tamper (wire cutting)

For each of these, the control panel reads different resistance values on the terminal, expressed below in Ohm.

$\Omega$	Zone 1	Zone 2 (double)
> 3900 + 6800	tamper	
3900 + 6800	alarm	alarm
6800	standby	alarm
3900	alarm	standby
0	standby	standby

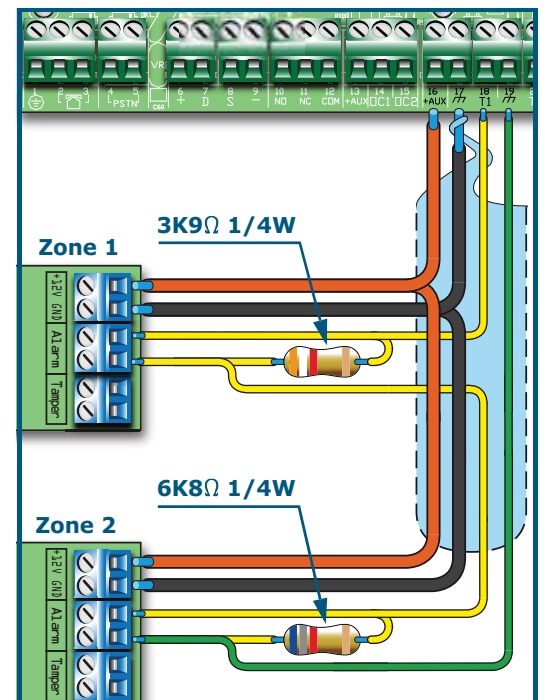

## Double Zone balancing with EOL 3-5-5

Double zones with EOL resistors can discriminate 6 conditions on the entire terminal:

- standby on both zones
- alarm on zone 1 and standby on zone 2
- alarm on zone 2 and standby on zone 1
- alarm on both zones
- tamper (wire cutting)
- tamper (short-circuit)

For each of these, the control panel reads different resistance values on the terminal, expressed below in Ohm.

$\Omega$	Zone 1	Zone 2 (double)
$> 2 \times 3900 + 6800$	tamper (wire cutting)	
$> 2 \times 3900 + 6800$	alarm	alarm
$3900 + 6800$	standby	alarm
$2 \times 3900$	alarm	standby
3900	standby	standby
0	tamper (short-circuit)	

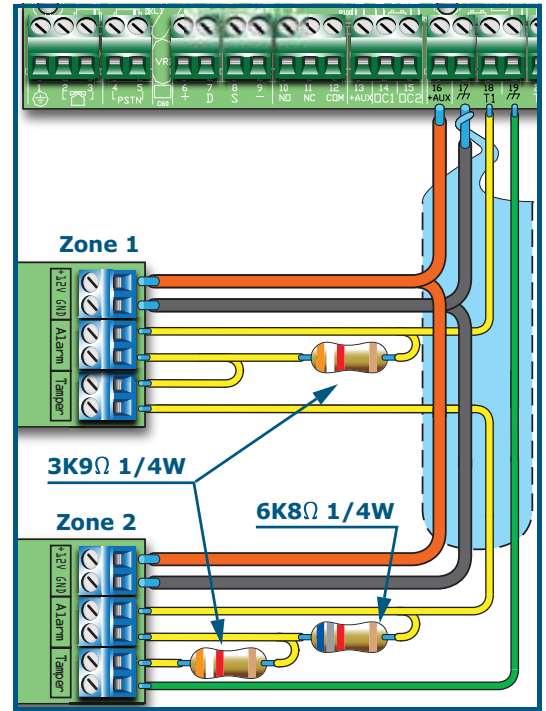

## Wiring and balancing rollerblind/shock sensors 3-6

It is possible to choose between two types of balancing for Rollerblind and Shock sensors:

- Normally Closed (N.C.)
- Single balancing (NC with EOL)

The following table compares the protection level of rollerblind/shock sensors using the two balancing options provided by the control panel.

Table 27: Protection level

BALANCING	N.C.	Single balancing (N.C. with EOL)
Rollerblind or Shock	very low	high

If the rollerblind or shock sensor is connected to a terminal of a wireless device, the connection cable must be less than 2 meters long.

The rollerblind sensor must generate pulses with a length of between  $500\mu\text{sec}$  and 10msec.

### Normally Closed (N.C.) 3-6-1

In this case, the alarm condition is revealed exclusively by the number of pulses (pulse count) the control panel detects on the terminal.

If this balancing method is applied, the control panel will be unable to detect tamper, wire-cutting or short-circuit.

The discriminated conditions are:

- standby
- alarm

The alarm condition is triggered by the number of pulses and sensitivity, in accordance with the programmed parameters (refer to paragraph 6-6 Zones - Detector type).



## Single balancing (N.C. with EOL)

### 3-6-2

In this case, the discriminated conditions are:

- standby
- alarm
- tamper (wire cutting)
- tamper (short-circuit)

For each of these, the control panel reads different resistance values on the terminal, expressed below in Ohm.

$\Omega$	Zone
$> 3900 / 2$	tamper (wire cutting)
$3900 / 2$	standby
0	tamper (short-circuit)

The alarm condition is triggered by the number of pulses and sensitivity, in accordance with the programmed parameters (refer to paragraph 6-6 Zones - Rollerblind/Shock).

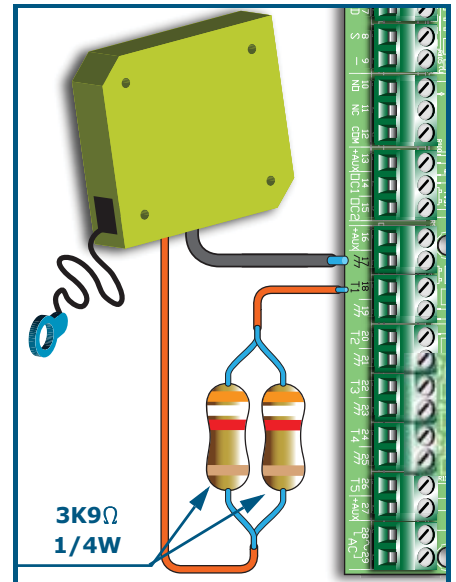

## Connecting wireless detectors

### 3-7

For the connection and deployment of wireless detectors (Air2-IR100 and Air2-MC100), refer to the Air2-BS100 Installation Guide.

For the connection and balancing of detectors connected to terminals "T1" and "T2" of the Air2-MC100 device, refer to paragraphs 3-5-1, 3-5-2, 3-5-3, 3-6-1 and 3-6-2.

It is necessary for the "GND" terminal of the Air2-MC100 device to be connected to GND (Negative) of the power source of the detector connected to terminals "T1" or "T2".

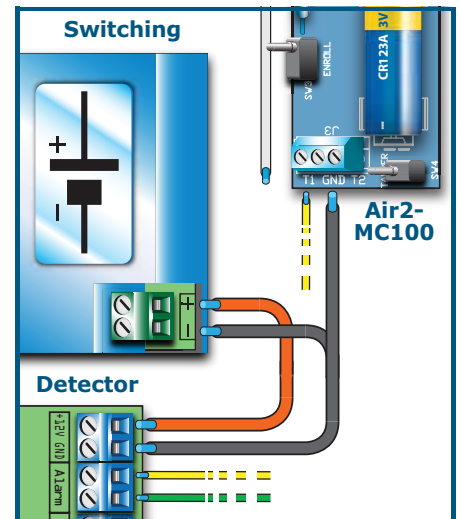

## Learn Zone Balancing

### 3-8

Once you have completed the wiring and configured the balancing of all the zones, you can instruct the control panel to save all the related parameters automatically, by activating the Learn zone bal. option (refer to paragraph 6-23 Default settings, Learn zone bal.).



## Connecting the outputs

### 3-9

It is possible to set up the outputs to activate in response to the events the control panel manages.

For the connection of the outputs to terminals "T1" and "T2" of the Air2-MC100 device, refer to the Air2-BS100 Installation Guide.

## Connecting the sounders

### 3-9-1

In the event of intrusion alarm, the control panel activates the output/s which are connected to the audible/visual signaling devices. The relay output on the control panel motherboard is the alarm output which is most commonly used to drive a self-powered sounder.

The following wiring diagram shows the connection of a self-powered sounder (IVY manufactured by INIM) and an indoor sounder.

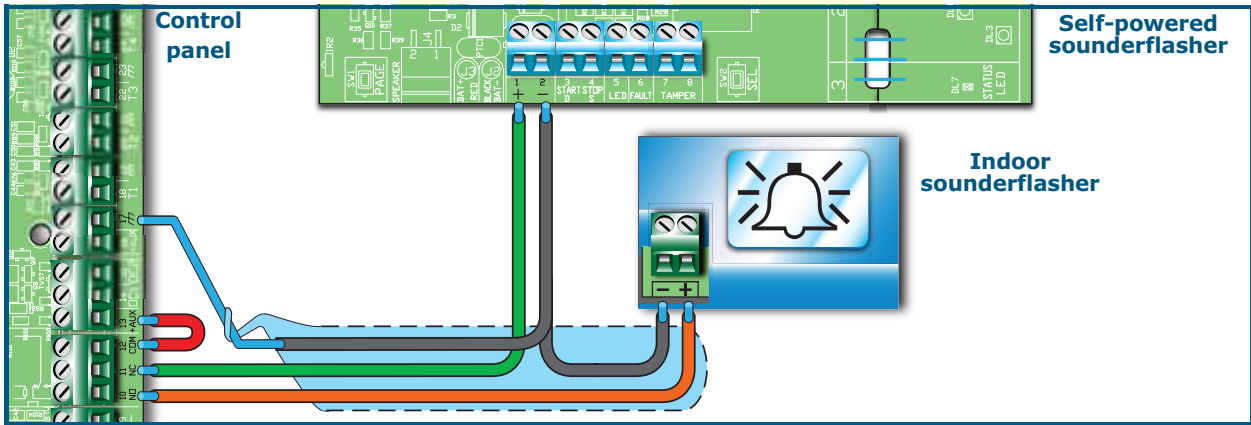

### Connecting open-collector outputs

3-9-2

All the system outputs, except for the relay output on the control panel motherboard, are open-collector outputs.

- OC1 and OC2 are open-collector outputs that sink maximum currents in accordance with the *Table 3: Control panel - Main Features*.
- All the terminals configurable as outputs are open-collector outputs that sink a maximum current of 150 mA.

The wiring diagram below illustrates a series of typical connections which activate the load of a Normally Open output when it closes to GND ( ).

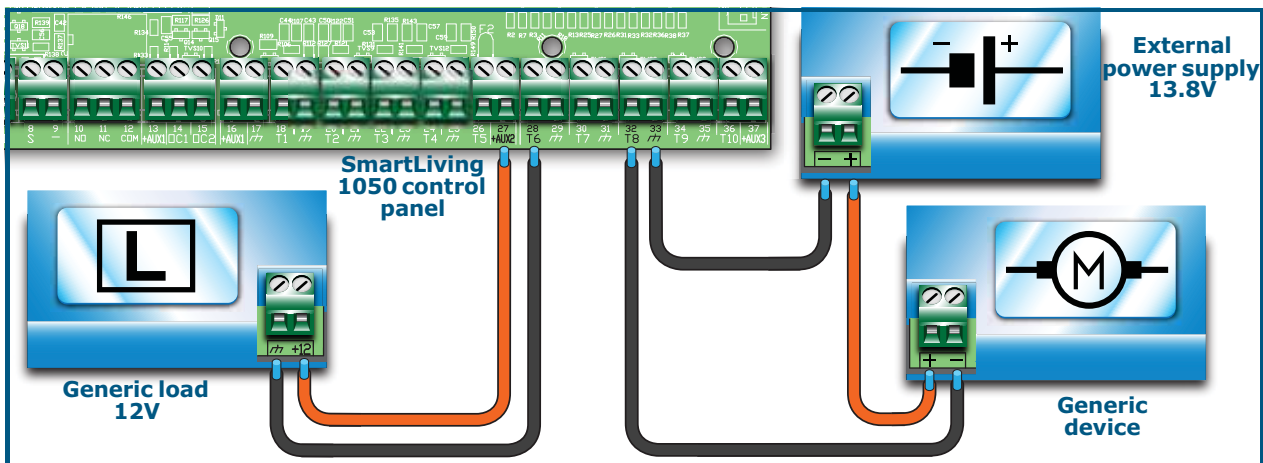

### Attachment boards

3-10

#### AUXREL32

3-10-1

The AUXREL32 power distribution board (accessory item) can be used with SmartLiving 1050L and 10100L models. It provides two relays and allows the system to take full advantage of the current supplied by the control-panel power-supply. It comprises 3 pairs of terminals protected by resettable fuses (GND/AUX1 - GND/AUX2 - GND/AUX3), each able to provide 12V@1A.

Each relay, has a voltage-free contact identified by terminals C1-NO1-NC1 and C2-NO2-NC2. The relays are activated by the control panel outputs OC1 and OC2.

Table 28: **AUXREL32 - description of parts**

<b>A</b>	Terminal board
<b>B</b>	12V connector
<b>C</b>	OC1/OC2 connector
<b>D</b>	Relay LED 1
<b>E</b>	Relay LED 2
<b>F</b>	12V present LED
<b>G</b>	Screw locations
<b>H</b>	OC1/OC2 connection wire
<b>I</b>	12V power wire

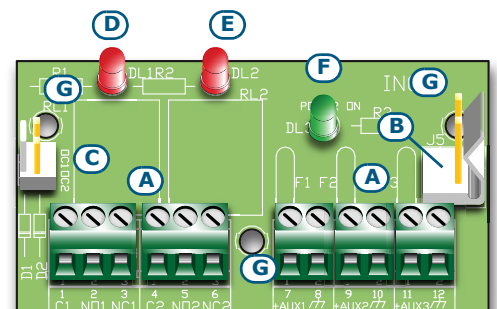

The activation of each relay is signaled by the on-board LED ([D] for relay 1 and [E] for relay 2).

If you intend installing this board, work carefully through the following steps.

1. Disconnect all sources of power to the control panel (Mains 230V a.c and battery power).
2. Insert the plastic supports into their respective locations (*Table 4: Control panels - description of parts, Z*) on the back of the metal enclosure.
3. Position the board holes [G] on the supports and push the board towards the back of the enclosure until it locks into position.
4. Insert the cable [H] into the connector [C].
5. Connect the two free wires of the cable [H] to terminals 14 (OC1) and 15 (OC2) on the control panel motherboard. Ensure that OC1 and OC2 on the control panel are appropriately connected to the connector [C].
6. Connect the cable [I] to the connector [B] and to the 2 free pins [J] of the connector on the switching power-supply, as shown in the figure.

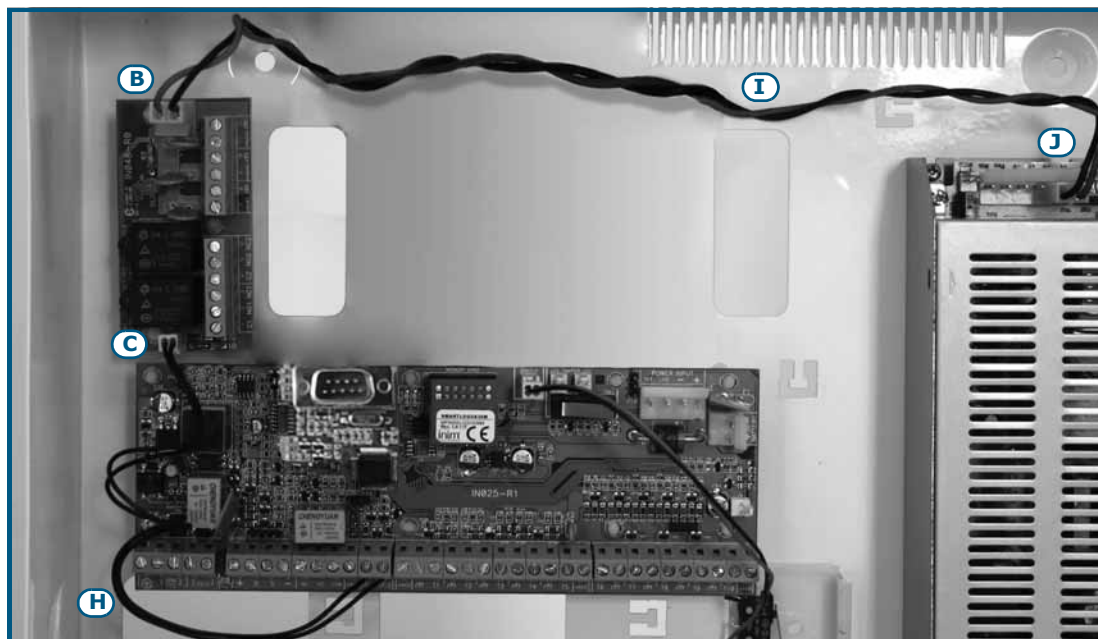
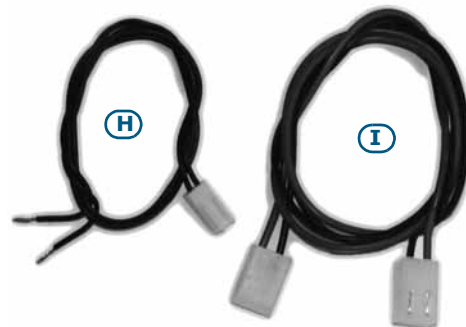

### SmartLink/GWB 3-10-2

The metal enclosures of SmartLiving 1050L and 10100L control panels provide housing for SmartLink/GWB accessory boards and the respective 12V@1.2Ah backup batteries.

For the technical features and functions provided by these boards, refer to paragraph 3-1-7 *Land-line connection (PSTN)*.

The SmartLink/GWB kit includes:

- SmartLink/G board
- GSM antenna with 3 meter cable
- Screws and star washers
- Plastic supports for box mounting
- 10 resistors @ 15KΩ 1/4W

The picture opposite shows the SmartLink mounted inside its enclosure. If you intend installing this board, work carefully through the following steps.

1. Disconnect all sources of power to the control panel (Mains 230V a.c and battery power).
2. Insert the plastic supports into their respective locations (*Table 4: Control panels - description of parts, C1*) on the back of the metal enclosure.
3. Position the board holes [A] on the supports and push the board towards the back of the enclosure until it locks into position.
4. Secure the screw and star washer in place [B].
5. Connect terminal "1" ([C] "PWR+") to a "+AUX" terminal on the control panel motherboard, and terminal "2" ([C] "PWR-") to a "GND" terminal on the control panel motherboard.
6. Power up the control panel (reconnect Mains 230V a.c and battery power).
7. Locate the battery properly into its housing (*Table 4: Control panels - description of parts, E1*) and connect the wires [D] (red-positive, black-negative).

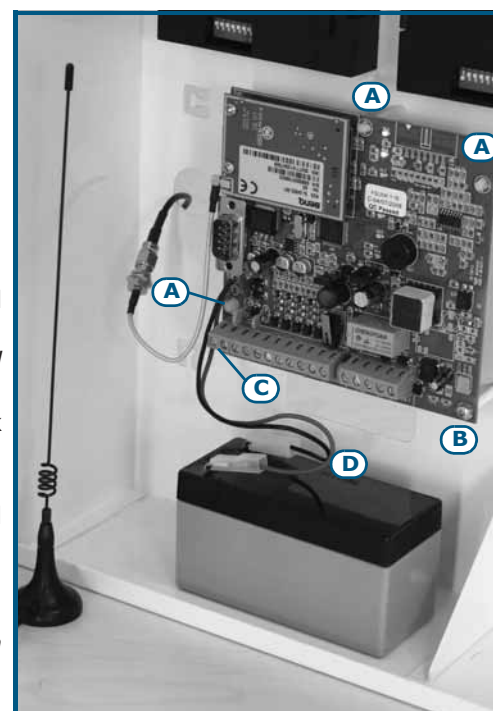

## Flex5/U 3-10-3

The metal enclosures of SmartLiving 1050L and 10100L control panels provide housing for two Flex5/U expansion boards (accessory items).

If you intend installing this type of board, work carefully through the following steps.

1. Disconnect all sources of power to the control panel (Mains 230V a.c and battery power).
2. Secure the plastic enclosure of the Flex5/U to the backplate of the control panel (*Table 4: Control panels - description of parts, B1*).
3. Connect it to BUS line as described in paragraph 3-2-1 *The I-BUS line wiring*.
4. Address it as described in paragraph 3-3-2 *Addressing FLEX5 expansions and the Air2-BS100 transceiver*.
5. Power up the control panel (reconnect Mains 230V a.c and battery power).

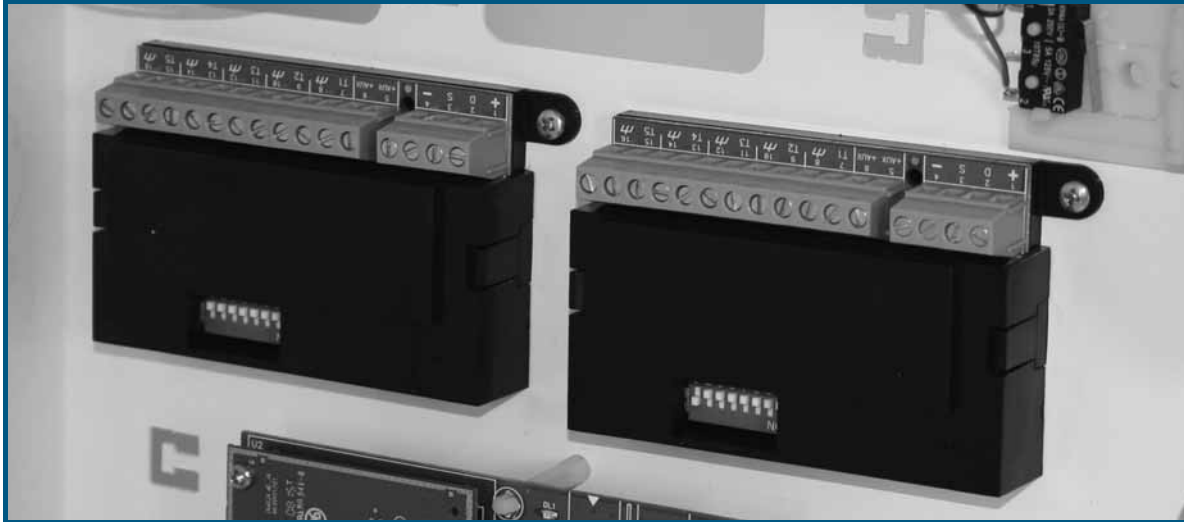

## SmartLAN 3-10-4

The SmartLAN board, available with SmartLAN/G and SmartLAN/SI versions, allows SmartLiving control panels to extend their connectivity to ethernet and internet networks.

The operating capacity of the SmartLAN board depends on the proper configuration of the networks it is connected to. Therefore, if you are installing a SmartLAN board, it is necessary to contact the network administrator in order to configure it correctly.

For a full description of the features and method of configuration of the SmartLAN board (IP address, gateway, e-mail, etc.), read carefully through the respective Guide.

The figure opposite shows the SmartLAN/SI board mounted inside the box. If you intend installing this board, work carefully through the following steps.

1. Disconnect all sources of power to the control panel (Mains 230V a.c and battery power).
2. Remove the earth connection screw [A] (*Table 4: Control panels - description of parts, A1*) from its location and replace it with the metal support (included).
3. Align the screw location on the board with the support and serial connector on the backplate [B], with the connector on the SmartLiving board (*Table 4: Control panels - description of parts, S*).
4. Fasten the screw [A] on the support.
5. Insert the board power jumper between pins 1 and 2 of the connector (*Table 4: Control panels - description of parts, O*). For SmartLiving 515 model without this connector, use the cable jack and connect it to the connector [C], then connect the free red [D] and black [E] wires respectively to terminals "+" and "-" of the control panel BUS.
6. Power up the control panel (reconnect Mains 230V a.c and battery power).

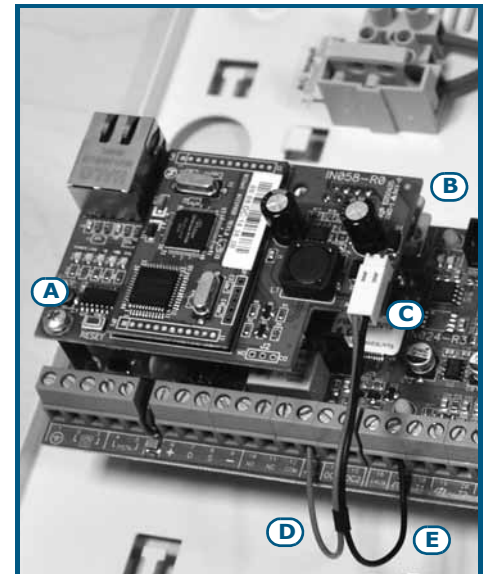

### Note

It is important to note that the e-mail service does not guarantee delivery time of e-mails and their attachments nor even their final delivery.

# Chapter 4

## FIRST POWER UP

On first power up, the control panel initializes the parameters at default (factory settings).

The control panel also enrolls all the peripherals it finds on the I-BUS automatically (automatic addressing phase). The default address of all expansions, keypads and readers is address 1, therefore, if the system is equipped with more than one of each type of device, the automatic enrolling operation will be erroneous. In order to allow the system to perform an accurate auto-enrolling operation on "First power-up", work carefully through the following steps.

---

The default address of all peripherals (keypads, readers and expansions) is set at address 1.

---



---

**When wiring the system, be careful not to allow any form of power (mains 230V or battery) to reach the control panel or its peripherals.**

---

1. Attach the control panel to the wall.
2. Complete the wiring of the peripherals to the BUS.
3. Connect the BUS wires to the control panel.
4. Complete the wiring and balancing of the system detectors.
5. Connect the detectors to the terminals.
6. Connect the outputs to the control panel and peripheral terminals.
7. Connect the control panel to the telephone line.
8. Connect the SmartLogos30M board to the appropriate connector on the control panel motherboard.
9. Insert the Service jumper in the "SERV" position.
10. Connect the primary power source (230V a.c.).
11. Connect the backup battery. The first line of the display of each keypad in the system will show the 'Maintenance' message and the keypad address at default. On first power up (first startup), all the keypads will show "K01" (refer to paragraph 3-1-10 *Maintenance status*).

---

If several keypads are connected to the I-BUS, their displays may be blank. If this occurs, disregard this aspect and go directly to the next step.

---

12. Address the peripherals (refer to paragraph 3-3 *Addressing the peripherals*). At least one keypad must be assigned to address 1. Using keypad 1, initialize the addressing phase for nBy/S and nBy/X readers (refer to paragraph 3-3-3 *Addressing nBy readers*).
13. If you wish to instruct the system to learn the "balancing values" of all the zones, initialize the procedure via the installer menu (refer to paragraph 6-23 *Default settings, Learn zone bal.*).
14. Remove the jumper from the "SERV" position and place it in the "RUN" position.
15. If necessary, specify the expansion terminals simulated by the Air2-BS100 transceiver (refer to paragraph 6-5 *Terminals*) as "Wireless" terminals.
16. If you decide to set up the voice and digital dialer functions and edit the contact numbers (refer to paragraph 6-8 *Telephone*).

**Note**

**ATTENTION!**

**Note**

# Chapter 5

## INSTALLATION PROJECT VIA SMARTLEAGUE SOFTWARE

The especially designed SmartLiving system can be programmed from a keypad or via PC. All programming functions can be accessed through the software programme. You will need:

- A computer (to be connected to the control panel)
- The SmartLeague software programme

### The SmartLeague software programme

### 5-1

The SmartLeague software programme allows the installer to prepare the majority of the parameters/settings without actually being connected to the control panel.

However, connection is required during the upload and download operations. The type of connection depends on the method used for upload/download operations to and from the control panel:

- RS232 serial port of the PC
- LAN (combined with the use of a SmartLAN/SI or SmartLAN/G board)
- Modem

The programming parameters of an installation constitute the "solution". The solution can be saved to the memory of the SmartLeague software programme, either for future use or as a "model" for other installations.

The homepage of the SmartLeague software programme is common to all the programmable devices and is always active, even during the programming session (in the form of a template):

Table 29: **SmartLeague software programme - homepage**

<b>A</b>	The menu bar, application icons and programming accessories.
<b>B</b>	List of recent solutions - which will allow you create new solutions or open existing solutions
<b>C</b>	Documentation installed on the computer.
<b>D</b>	Area dedicated to help and service via Internet. It is possible to consult FAQ page, make enquiries and suggestions via e-mail.
<b>E</b>	Access to the area reserved for registered users of the INIM website. After typing in a Username and Password, you can access the updated versions of the software programme, firmware, technical documentation and service.



## Using the software programme

## 5-2

Each project, from the most uncomplicated to the most complex of systems, is represented by a solution, which contains the programming parameters and installation structure.

A solution is dedicated to a specific type of apparatus and has its own programming interface. You can work on several solutions simultaneously, even if they involve different types of apparatus. Each solution has a template, located next to the "Homepage", which can be viewed at all times. In this way it is possible to compare different solutions and even keep two solutions open, one real and one for test purposes (in order to verify the effects of programming).

When a solution opens, the SmartLeague software programme presents the following interface:

Table 30: **SmartLeague - solutions**

<b>A</b>	The freshly opened template remains in the forefront whilst the other open template and the Homepage remain in the background.	
<b>B</b>	Installation tree structure.	
<b>C</b>	Project Template where you can select the system peripherals (keypads, readers, expansions, sounderflashers) and drag and drop them to the tree structure.	
<b>D</b>	Programming template of the component to be programmed (selected from the tree structure).	
<b>E</b>	Keys for data transfer	

A solution can be created or changed even without being connected to the apparatus. For example, you can plan the layout of an installation or set the options/parameters at your office and download the settings to the system at a later time.

In this case, you must:

- Enter the Installer PIN - select "SmartLiving System" from the tree menu on the left and type in the code in the "Parameters settings - Installer code" section on the right.
- Select the Type of connection - either from the "Settings - Application data" section, when using the serial port or a LAN connection, or by pressing the key, when using the SmartModem100.

For the full instructions regarding these connections, refer to the SmartLAN board or SmartModem100 Installation Manual.

## Creating a Project layout

## 5-3

The Project layout section, in the SmartLeague software programme, allows you to select the number of peripheral devices you wish to install and thus plan and configure the system.

You can either create a new solution or change an existing one. The existing solution can be either a project layout created through the SmartLeague application or a solution imported directly from a real system.

1. If you wish to create a new system, go to the "Recent Solutions" section and select "New solution", then select the type of control panel and firmware version.  
If you wish to modify an existing system, go to the "Recent solutions" section and select "Open solution".  
or  
import the data from a real control panel by clicking on the key, which will upload the control panel data.
2. Select the type of peripheral you wish to configure from the "Project" template, and drag and drop it to the part of the tree menu concerned.  
or  
Double-click on the peripheral to add it to the configuration.  
To remove a component from the structure, select it and press CANC on the computer keyboard.

3. To download the data to the control panel, click-on the  key. Downloading operations will:

- Block all system keypads.
- Broadcast the "PROGRAMMING" message to all the keypads.
- Force all the system keypads to standby status.
- Bring the call queue and events log to a temporary standstill, thus there will be no events saved to the log, no outputs activated and no outgoing calls.

When the downloading phase terminates, the control panel will restore the system to normal operations, as described in paragraph 6-2 *Programming from a keypad (accessing the installer menu)*.



## PROGRAMMING FROM COMPUTER

---

During uploading and downloading phases, ensure that the control panel partitions are disarmed. This condition is not necessary when you are viewing the events log.

---

### Note

The SmartLeague software programme provides data transfer buttons ( and ) for upload/download operations regarding all programming in progress, located under the Menu bar. And, also for upload/download operations relating to the project layout or open programming session, located in the top left-hand corner of the page.

4. The SmartLeague software programme also provides a key  which allows you to create WinMag interface file (contact your installer company for further details).



# Chapter 6

## OPTIONS AND PROGRAMMING METHODS

### Introduction 6-1

The options, functions and values of the SmartLiving control panel must be programmed by qualified persons only. The SmartLiving control panel is programmed at the factory with almost ready-to-go settings ("default settings") which require only minor changes during the system customization phase.

For example, all the zones, keypads and readers are assigned to (belong to) partition 1, alarm and tamper events related to partition 1 activate the relay output which is monostable set at 3 minutes (Monostable time = 3 minutes), etc.

All the parameters and programming data can be input via keypad or computer (equipped with the SmartLeague software programme) with the following exceptions.

- From the keypad you cannot programme:
  - Timer slot exceptions
  - Input calibration
  - The second partition entry time
  - Sounderflasher tone
  - BUS speed
  - Description of the "Emergency key duos"
  - Parameters relating to the SmartLAN board
  - Parameters relating to the Nexus GSM dialer
  - Parameters relating to the I-BUS Ivy-B
  - Programmable events
- Via the SmartLeague software programme you cannot programme:
  - DTMF sensitivity
  - The second Installer code
  - The Installer code PINs
  - The shortcut descriptions

The following chapter describes the programming flow of the system data as it appears in the Installer menu on the keypad. The description of both programming methods (from Keypad; Via PC) are provided.

### Programming from a keypad (accessing the installer menu) 6-2

If you wish to programme the system via the installer menu from a keypad, you must:

1. Disarm all the control panel partitions.
2. Type-in a valid PIN (installer code) on the keypad then press **OK**. The PIN is "9999" at default.

If you satisfy these conditions, the system will allow access to installer menu.

Once access to the installer menu is achieved, the system will:

- Block all system keypads except the one you are using.
- Broadcast the "PROGRAMMING" message to all the keypads.
- Force all the system keypads to standby status.
- Bring the call queue and events log to a temporary standstill, thus there will be no events saved to the log, no outputs activated and no outgoing calls.

To exit the installer menu, press **Esc** or **C**, and when the system asks: "EXIT?" Press **OK** (OK = YES).

When you exit the installer menu, the control panel will:

- Apply all the new settings and values.
- Restore the I-BUS, reprogramme and make all the peripherals fully operational.
- Restore the call queue, and events log to normal operations.

## Programming via the SmartLeague programme

Certain parameters (for example, relating to zones and outputs) can be programmed only after the project layout of the system has been completed (refer to paragraph 5-3 *Creating a Project layout*).

1. Go to the "Recent solutions" section and either create a new solution or open an existing solution, or import the programming data of a real control panel by clicking on the key to upload the control panel data.
2. Select the device you wish to configure from the tree menu on the left.
3. Set the parameters in the "Parameters settings" template on the right.
4. To download the data to the control panel, click-on the key.

The limitations described in paragraph 5-3 *Creating a Project layout* apply during the uploading and downloading phases.

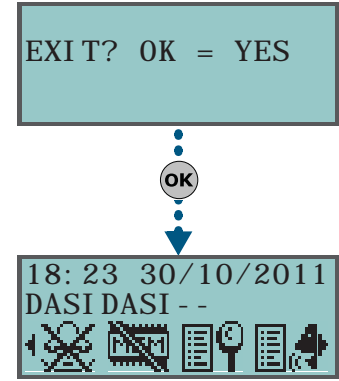

**Note**

## Panel options 6-4

The following options are provided by the control panel.

Table 31: Panel options

Option	If enabled	If disabled
<b>Dial tone check</b>	The control panel will engage the telephone line and check for the "dial tone", if present, the control panel will start dialing.	The control panel will engage the telephone line, wait two seconds then will start dialing (whether the dial tone is present or not).
<b>Pulse dialing</b>	The control panel will dial using pulse tone.	The control panel will dial using touch tone (DTMF).
<b>DTMF withoutCode</b>	Allows access to the User Menu over-the-phone (during voice calls from the control panel) in accordance with the access level (enabled options, etc.) of the last user code that operated on the control panel (code 30, 50 or 100).	Allows access to the User Menu over-the-phone during voice calls from the control panel, only after entry of a valid user-code PIN by the recipient.
<b>Line down signal</b>	If a "Tel.Line down" event occurs, the control panel will flash the respective icon  on the keypad displays.	The control panel will detect the "Tel.Line down" event, but it will not be revealed on the keypad displays.
<b>Double call</b>	The control panel will override the answerphone function.	
<b>Call allVoxNums</b>	If several voice calls - generated by the same event - are waiting in the outgoing call queue, the control panel will attempt to send voice calls to all the numbers.	If several voice calls - generated by the same event - are waiting in the outgoing Call Queue, the control panel will attempt to send voice calls until just one call ends successfully. Any other voice calls relating to the event in question will be cleared (deleted) automatically from the queue .
<b>Call all TLVNums</b>	The same as <b>Call all VoxNums</b> , but related to Alarm Receiving Centres.	
<b>RefreshMnstblOut</b>	Each event that triggers an already-activated monostable output will refresh (take back to zero) the programmed Monostable time.	Each event that triggers an already-activated monostable output will not refresh (take back to zero) the programmed Monostable time.
<b>Num10 ForTeleserv</b>	Telephone number 10 in the phonebook is reserved for Teleservice (maintenance over-the-phone). If an end-user makes a request for Teleservice, the control panel will contact the number in position 10. <b>Note</b> If you wish the control panel to call an installer company number which uses an INIM modem, you must set "None" in the Telephone Number Type field.	Telephone number 10 in the phonebook can be dedicated to either voice or Teleservice.

Table 31: Panel options

Option	If enabled	If disabled
<b>Install.callback</b>	The control panel will enable the Teleservice function if: <ul style="list-style-type: none"> <li>the installer calls the control panel</li> <li>the control panel detects the ring, picks up, recognizes the installer code and hangs up immediately</li> <li>the control panel calls the Teleservice number and allows access to the system</li> </ul>	
<b>ReaderBuzzer OFF</b>	No reader buzzers will emit audible signals during running entry time, exit time, output time or pre-arm time.	
<b>Keypad lockout</b>	If a wrong code is typed-in at a keypad more than 5 times in succession, the keypad will lock for 10 minutes and show the icon: <div style="text-align: right;"></div> <p><b>Note</b></p> <p>If you reset the control panel or access programming while the keypad-lockout time is running, it will refresh to zero and start again.</p>	
<b>View open zones</b>	The keypad will show the descriptions of any open zones (zones which are not in standby status) when the partitions disarm. Any autobypassable open-zones will be shown in white on a black background.	
<b>OpenZonesArmLock</b>	The control panel will not arm the partition if it detects any open zones (zones which are not in standby status). If there are zones with the "Auto-bypassable" or "No-Unbypassable" attribute amongst the open-zones (refer to paragraph 6-6 Zones), they will be shown on the keypad as "Not ready". If the user goes ahead with the arming operation, these zones will be bypassed automatically and the partition will arm.	
<b>DTMF sensitivity</b>	The sensitivity of incoming DTMF tones is increased.	
<b>BypassAlsoTamper</b>	If a zone is bypassed (disabled), it will also be unable to generate terminal tamper.	If a zone is bypassed (disabled), it will be able to generate terminal tamper.
<b>BypassVoiceCheck</b>	The control panel will start the voice message 5 seconds after dialing the respective contact number.	The control panel will not start the voice message until it recognizes a voice at the other end of the line.
<b>Confirm with "*"</b>	The control panel will consider the voice call successful when the recipient presses  OR  on the telephone keypad.	The control panel will consider the voice call successful as soon as it starts the voice message.
<b>NoUserTamp.reset</b>	No user will be allowed to delete of the following events: <ul style="list-style-type: none"> <li>terminal tamper</li> <li>control panel open-tamper</li> <li>control panel dislodgement-tamper</li> <li>peripheral tamper</li> <li>peripheral loss</li> <li>false key</li> </ul>	
<b>Encrypt data</b>	The control panel will encrypt data via LAN (for SmartLAN/SI only).	
<b>Instant restoral</b>	The restoral of the magnetic reed sensor in Air2-MC100 wireless detectors will be signaled instantly.	The restoral of the magnetic reed sensor in Air2-MC100 wireless detectors will be signaled with a 10 second delay (maximum).
<b>Teleserv. hidden</b>	The  symbol will not be shown on the keypad display.	If Teleservice is enabled, the  symbol will be shown on the keypad display.
<b>LockInstall.Code</b>	After hard reset (refer to paragraph 6-23 Default settings), all the control panel parameters with the exception of the installer PIN will reset to the factory default settings.	After hard reset (refer to ), all the control panel parameters including the installer PIN will reset to the factory default settings (installer PIN default is 9999).
<b>50131ReaderLedOFF</b>	If there are no keys present at the reader, the LEDs of nBy readers will be Off. If a key is waved across the reader, the status will be indicated on the LEDs for 30 seconds before switching Off again. During this 30 second phase, the user can hold the key in the vicinity of the reader and select the desired shortcut indicated by LEDs.	The reader LEDs indicate the related status.

Table 31: Panel options

Option	If enabled	If disabled
<b>50131StatHidden</b>	<p>The status of the partitions will be hidden. If a valid code is entered at a keypad, the real-time status will be indicated on the keypad concerned for 30 seconds.</p> <p>If the partitions are armed, the status of the system will be hidden from non-authorized users.</p> <ul style="list-style-type: none"> <li>• Red keypad LED Off</li> <li>• Yellow keypad LED Off</li> <li>• Green keypad LED On solid</li> <li>• Status icons not present</li> <li>• Alarm and Tamper memory hidden</li> <li>• If a particular event occurs more than 5 times when the partitions are armed, it will not be signaled as having occurred more than 5 times. This is due to the limitation placed on the counter of each event. The counters will reset to zero each time all the partitions are disarmed.</li> </ul> <p>If the partitions are DISARMED:</p> <ul style="list-style-type: none"> <li>• The LEDs will function normally.</li> <li>• Status icons present</li> <li>• Alarm and Tamper memory visible</li> </ul>	<p>The keypad will show the real-time status of the system at all times, regardless of the status of its partitions.</p>
<b>50131IconsHidden</b>	<p>If partitions are armed, the status icons will be hidden from non-authorized users.</p> <p>If a valid code is entered at a keypad, the status of the icons will be shown for 30 seconds.</p> <p>The keypad will show the real-time status of the icons when all the keypad partitions are disarmed.</p>	<p>The keypad will show the real-time status of the icons at all times, regardless of the status of its partitions.</p>
<b>50131AlarDelayed</b>	<p>If an instant-zone alarm occurs on a partition while entry time is running, the associated actions (calls, output activation, save to log, etc.) will not be generated until 30 seconds after the expiry of the entry time.</p> <p>If the partition (or partitions) are disarmed during this period, the associated actions will not be generated, however, the keypads will indicate the violation of the instant zone.</p>	<p>If an instant-zone alarm occurs on a partition while entry time is running, the associated actions (calls, output activation, save to log, etc.) will be activated instantly.</p>
<b>50131WarnLedMem</b>	<p>If the control panel detects a fault, the yellow LED on the keypads will go On and will remain On even after the fault clears.</p> <p>To switch the yellow LED Off, clear all activating causes and reset the partition.</p>	<p>If the control panel detects a fault, the yellow LED on the keypads will go On and will go Off automatically when the fault clears.</p>
<b>DayLightSav.time</b>	<p>The control panel clock will go back automatically one hour at 03:00 last Sunday in October, and it will go forwards automatically one hour at 02:00 last Sunday in March.</p>	<p>No automatic clock forward/back operations.</p>
<b>NoStringsSiaProt</b>	<p>The descriptive strings will not be sent in SIA reporting format.</p>	<p>The descriptive strings will be sent in SIA reporting format.</p>
<b>Nexus prior</b>	<p>Voice calls will be diverted to Nexus dialer.</p>	<p>Voice calls will be diverted to Nexus dialer only when the PSTN line is down.</p>
<b>Invert CONTACT-ID</b>	<p>Partition arming events using CONTACT-ID reporting format will send the "New event/Event activation" code when the partition is armed and the "Event ended/Event restore" when the partition is disarmed.</p>	<p>Partition arming events using CONTACT-ID reporting format will send the "New event/Event activation" code when the partition is disarmed and the "Event ended/Event restore" when the partition is armed.</p>

## Terminals

## 6-5

This section describes the configuration flexibility of the system terminals. The profile of each terminal can be configured as follows.

- Programme the type of terminal:
  - **Input (I)**
  - **Output (O)**
  - **Two way - supervised output (T)**
  - **Double Zone (D)**
  - **Unused (-)**
- Programme the parameters related to the selected configuration

**For critical events or events of particular importance, it is advisable to use keypad terminals T1 and T2 as the signal outputs. The status of these outputs may switch (On to Off and vice versa) in the event of BUS reset.**

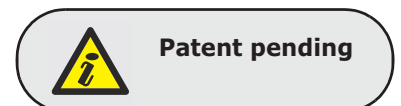

## ATTENTION!

### Via Keypad

1. Access the "Programming Terminals" section.

Type in Code (Installer PIN) **OK**, PROGRAMMING Terminals **OK**.

The display will show the:

- 1° riga: the number of terminals
- 2° line: the type of terminals and the selected terminal
- 3° line: the description of the selected terminal
- 4° line: the description of the second zone of the selected terminal if it configured as a DOUBLE ZONE.

2. Use and to select the device whose terminals you wish to configure. The terminals are arranged as follows:

- terminals from 1 to 5 on the control panel
- terminals from 6 to 10 on the control panel (SmartLiving 1050 and 10100)
- terminals on expansion boards
- terminals on keypads

3. Use and to scroll across the terminals. The selected terminal will blink. Configure the terminal by pressing:

- **1** ., to configure the terminal as an INPUT ("I")
- **2** abc to configure the terminal as an OUTPUT ("O")
- **3** def to configure the terminal as a TWO WAY - SUPERVISED OUTPUT ("T")
- **4** ghi to configure the terminal as a DOUBLE ZONE ("D")
- **5** jkl to configure the terminal as UNUSED ("-")
- **6** mno to enable/disable the terminal as "Wireless"

4. Once you have configured the terminal, press **OK**, , , or to configure its type.

If an UNUSED terminal is configured as **I**, **O**, **T** or **D** and the keypad emits an error "beep", it means that you have exceeded the maximum number of terminals available on the control panel. If you wish to employ the terminal concerned, you must first configure another terminal as UNUSED.

If you are working on a Flex5 expansion terminal, press key **6** mno to configure it, and consequently the entire expansion, as wireless. The "Wireless" string will be shown on the bottom line of the display. If you press key **6** mno again, the operation will undo.

To configure a terminal as a wireless output, proceed as follows:

1. Position the cursor on the terminal concerned.
2. Press **6** mno to configure the terminal, and consequently the entire expansion, as wireless.
3. Configure the terminal as an "input" (**1** .,).
4. Press **OK** to access the zone parameters programming section.
5. Go to the "Wireless" section.
6. Enroll the terminal as "Input 1 C.M." or "Input 2 C.M."
7. Press the "ENROLL" button on the Air2-MC100 device.
8. Enable the "Broadcast RF" option as follows:

Type in Code (Installer) **OK**, PROGRAMMING Zones **OK**, select the zone, Options **OK**, BroadcastRF. **OK**

The "Broadcast RF" option must be enabled for each terminal of the Air2-MC100 device concerned.

9. Go back to step 1 and configure the terminal as an output (**2** abc).
10. Press **OK** to access the output parameters programming section (description, options, etc.).

Press **OK** in correspondence with any terminal, provided that it is not an UNUSED terminal, to access the parameter programming section of the type of terminal selected, whether it is a zone or an output (refer to paragraph 6-6 Zones or paragraph 6-7 Outputs).

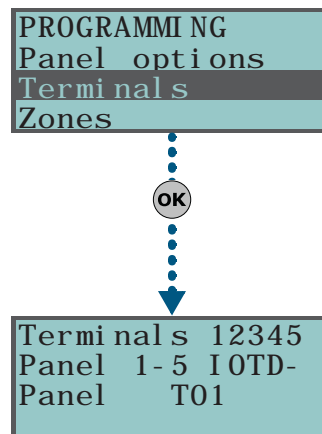

**To configure a wireless terminal as an "output", you must first enroll it as an "input", and then programme it as an "output", as described in the instructions (see opposite).**

### Note

### Via PC

Select "SmartLiving System - Terminals" from the tree menu on the left, then go to the "Parameters settings" template on the right:

All the terminals will be shown on the respective page. You must configure the terminal graphically using the mouse, as follows:

1. Point to the terminal you require.
2. Right click on the mouse and select the required type.
3. Double click to set the options for the terminal.
4. Position the mouse on the programming field instead of on the specific terminal to configure all the terminals in the same way.

If the terminal is configured as "Zone" (=INPUT) or "Double" (=DOUBLE ZONE), it will appear in the Zone programming section (paragraph 6-6 Zones). If the terminal is configured as an "Outputs" (=OUTPUT) or "I/O" (= TWO WAY), it will appear in the Outputs programming section (refer to paragraph 6-7 Zones).

## Zones 6-6

This programming section deals with all the zone parameters.

### Via Keypad

1. Access the "Programming Zones" section.

Type in Code (Installer PIN) , PROGRAMMING Zones .

2. Use keys and to select the zone then press .

#### Description

This is the editable label which identifies the zone. At default, all the zones assume the description of the peripheral they refer to, followed by the respective terminal.

- 1° *riga*: default description
- 2° *line*: current description
- 3° *line*: description being edited
- 4° *line*: letter/number selection

For example, the default description "Expansion 04 T03 corresponds to the zone located on terminal T3 of Expansion n. 4. The default descriptions "Panel T05" and "Panel T05D" correspond to the two zones located on terminal T5 of the control panel, configured as "Double Zone".

#### Partitions

These are the partitions the zone belongs to. A zone configured as "Automation" cannot be assigned to any partition.

Use \* and # to enable or disable the selected partition.

#### Type

Use and to select the type of zone, then press . The available Types are (refer to *Appendix A, Technical terminology and Glossary*):

- **Instant**
- **Delayed**
- **Delayed unhidden**
- **Route**
- **24 hour**
- **Automation**
- **Armed in Away mode**
- **Disarm**
- **Switch**
- **OnArm/OffDisarm**
- **Patrol**

For "Arm", "Disarm", "Switch", "OnArm/OffDisarm" "Follow" and "Patrol" zones, refer to *Appendix A, Technical terminology and Glossary, Command Zones*.

"Delayed" and "Delayed unhidden" zones are delayed during entry and exit phases, in accordance with the respective "Entry Time" and "Exit Time" settings (refer to paragraph 6-11 Partitions). A "Delayed unhidden" zone behave as follows:

- if violated when the system is disarmed, it will switch Off the blue LED on the keypad

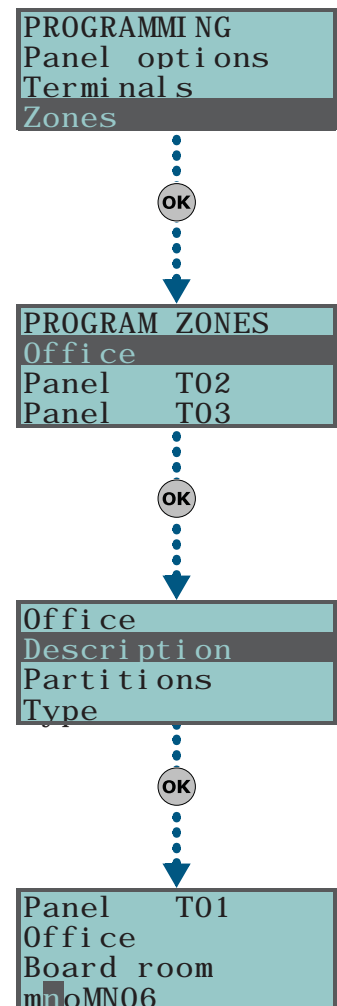

- if the "View open zones" option is enabled, it will be shown on the keypad
- it will not generate "Partition not ready" events
- On arming from a keypad, the zone will appear as a violated zone but, when the arming operation is confirmed, will behave as a delayed zone and will not generate an alarm.
- if the "OpenZonesArmLock" option is enabled and the zone is violated, it will appear as a violated zone but, when the arming operation is confirmed, will behave as a delayed zone and will not generate an alarm.
- if the "OpenZonesArmLock" option is enabled, the zone is violated and instant arming is required, the zone will appear as a violated zone and when the partition arming operation is confirmed, the partitions the zone belongs to will not be armed.

**Options**

The available options (refer to *Appendix A, Technical terminology and Glossary*) must be enabled/disabled by keys  \* and  #:

- **Interior**
- **Auto-bypassable**
- **Unbypassable**
- **Chime**
- **Test**
- **TampReed/FollPir**
- **Broadcast RF**
- **Use sensor LED**

The last three options apply to "Wireless" zones only, a full description of which follows.

Option	If enabled	If disabled
<b>TampReed/FollPir</b>	<ul style="list-style-type: none"> <li>• <b>Air2-IR100</b> - in order to increase battery life, the infrared sensor will deactivate when the partitions it belongs to are disarmed and will only activate when the partitions it belongs to arm. Deactivated detectors do not generate alarms. There may be up to a 3 minute delay between the partition arming command and when the detector actually arms.</li> <li>• <b>Air2-MC100</b> - detects magnetic-contact tamper when both reeds are in standby status.</li> </ul>	<ul style="list-style-type: none"> <li>• <b>Air2-IR100</b> - the PIR detector will be active at all times.</li> <li>• <b>Air2-MC100</b> - magnetic-contact tamper will not be detected under any circumstances.</li> </ul>
<b>Broadcast RF</b>	This option must be enabled when the zone and one of the terminals of the Air2-MC100 device ("T1" or "T2") is configured as an "output". Assures the activation/deactivation of the output within 2 seconds of the control panel command.	The activation/deactivation of the "wireless" output occurs within 2 minutes of the command from the control panel.
<b>Use sensor LED</b>	The red LED of Air2-IR100 and Air2-MC100 devices provides visual signaling of alarm and device tamper conditions. <b>Note</b> This option must be enabled on all the terminals of the Air2-MC100.	The red LED of Air2-IR100 and Air2-MC100 will be "Off" at all times.

- **No-Unbypassable** If this option is enabled, the zone will operate as an "Auto-bypassable" zone, with the difference that it will be automatically unbypassed when the partition next disarms.
- **NoArmIfNotReady**. If this option is enabled, the zone, even if it is a 24H, automation or delayed zone, will not arm when it is not in standby status. This option, for 24H or automation zones, can be used together with the control panel option "NoArmOpenZones", for management of the "antimask" function of detectors which have this feature.
- **Delay time 2**. If this option is enabled, delayed zones will activate the second partition entry time. If this option is not enabled, delayed zones will activate the first partition entry time.
- **Last exit zone**. If this option is enabled, and the zone passes from standby status to alarm status while the partition exit time is running, the exit time will be forced to 15 seconds. If the zone passes from alarm status to standby status, the exit time will be forced to 5 seconds.
- **UnbypassOnDisarm**. If this option is enabled, a zone which has been bypassed by a user, will be automatically unbypassed when the partition next disarms.
- **Hold-up**.
- **Fault zone**. If this option is enabled, violation of the zone will generate an Alarm event and contributes to fault signaling (yellow LED on the keypad).

## Wireless

Please note that this section will be operative only when the zone you are working on is configured as a wireless zone (refer to paragraph 6-5 *Terminals*).

This section allows you to carry out all the operations relating to the programming of Air2 wireless series devices. The wireless-device programming section is arranged as follows.

- **Enroll sensor** - allows you to enroll a wireless detector which has not yet been enrolled on the terminal concerned.



Press **OK** to initialize the enrollment process. Select the type of detector you wish to enroll:

- **PIR sensor** - allows you to enroll an Air2-IR100 detector
- **Magnetic contact** - allows you to enroll Air2-MC100 magnetic reed contact
- **Terminal T1 MC** - allows you to enroll the "T1" terminal of an Air2-MC100
- **Terminal T2 MC** - allows you to enroll the "T2" terminal of an Air2-MC100



After selecting the desired type, press **OK**. The first line of the keypad will show the "Programming" string.

To enroll the wireless device, press and release its on-board "ENROLL" button. As soon as the enrolling process is complete, the keypad will emit an audible signal (beep) to confirm the operation, and will show (in accordance with the type of device) the following:

- **Delete sensor** - allows you to delete (unenroll) an enrolled wireless detector from the terminal concerned.
- **PIR sensor** - allows you to change the parameters of an already enrolled Air2-IR100 detector. Press **OK** to programme the detector sensitivity and enter a value of between 1 (low sensitivity) and 4 (high sensitivity).

1. Use keys  or  to select the field you wish to change, then use the number keys (**1**, etc.) to edit the number.

or

Use key  or  to increase or decrease the number.

2. Press **OK** to confirm and exit.

- **Magnetic contact** - allows you to change the parameters of an already enrolled Air2-MC100 magnetic contact. Press **OK**, to access the following options:
  - **LongSide contact** - detection using the long side of the magnetic contact.
  - **ShortSideContact** - detection using the short side of the magnetic contact.
  - **Both contacts** - detection using both sides of the magnetic contact.

If you select the "Both contacts" option, standby status will be detected when either (or both) of the 2 reeds close. If you select either "LongSide contact" or "ShortSideContact", standby status will be detected when the selected reed closes and the other opens. If both reeds close, the system will generate a terminal-tamper event. In fact, the most common method of jamming this type of device is to hold a magnet in the vicinity of the magnetic contact, should this ever occur, both reed relays will close to trigger a tamper event.

- **Terminal T1 M.C.** and **Terminal T2 M.C.** - to change the parameters of terminal "T1" of an enrolled Air2-MC100. If you press **OK** at this point, the keypad will step back to the Zones menu and you can set up the parameters of the terminal: Balancing, Rollerblind, Times, etc.

Terminals "T1" and/or "T2" of the Air2-MC100 device can be set up in the same way as wired terminals, with the exception that wireless terminals cannot be configured as "double zones".

## Balancing

Balancing can be (refer to *Appendix A, Technical terminology and Glossary* and paragraph 3-5 *Wiring and balancing alarm detectors*):

- Norm. open (NO)
- Norm.closed (NC)
- Single balancing
- Double balancing
- Double Zone (without EOL)
- Double Zone EOL (with EOL)

## Note

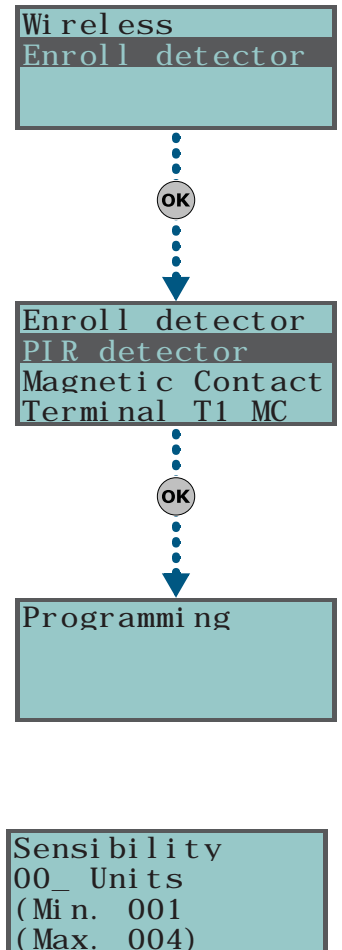



### Alarm cycles

This programmable parameter accepts values between 1 and 15. If you set the value at 15, the zone will operate as a "repetitive zone" (refer to *Appendix A, Technical terminology and Glossary, Alarm cycles*).

### Detector type

It is possible to configure a zone as:

- Generic zone
- Rollerblind
- Shock

The following Table shows the terminals which accept Generic, Rollerblind and Shock zones, and the respective zone-parameter fields for each type.

	Generic zone	Rollerblind	Shock
<b>Control panel terminals</b>	any	T1, T2	T1, T2
<b>Expansion terminals</b>	any	T1, T2, T3 or T4	T1, T2, T3 or T4
<b>Keypad terminals</b>	any	any	any
<b>Extra Parameters</b>	Al. pulse Duration Multipulse time Alarm pulses	Rollerblind time Rollerbl. pulses	Shock sensit. Shock time Shock pulses

#### Al. pulse Duration (generic zone)

This is the length of time (after detection of alarm conditions) the zone allows before generating an alarm. Expressed in multiples of 15 milliseconds or minutes (see "info" box).

#### Multipulse time (generic zone)

This parameter applies only when the "Alarm pulse num." parameter is more than 1.

This is the window during which a number of alarm pulses must be detected (each lasting as long as the programmed "Al.pulse Duration"). The number of alarm pulses must equal or exceed the value programmed for "Alarm pulses", before the system generates an alarm. This window can be expressed in seconds or minutes (see Note).

#### Alarm pulse num. (generic zone)

This is the number of pulses (each lasting as long as the programmed "Al.pulse Duration") necessary to generate a zone alarm event. If this value is more than 1, you must also programme the "Multipulse time" parameter.

#### Rollerblind time (rollerblind zone)

This parameter applies only when the value of the "Rollerbl. pulses" (see below) is more than 1.

This is the time window during which the system must detect a number of pulses equal to or higher than the value programmed for "Rollerbl. pulses" before generating a zone alarm. This window can be expressed in seconds or minutes (see Note).

#### Rollerbl. pulses (rollerblind zone)

This is the number of pulses necessary to generate a zone-alarm event. If this value is more than 1, you must also programme the "Rollerblind time" parameter.

#### Shock sensit. (shock zone)

This is an empirical parameter which regulates the sensitivity of the sensor. Increasing this value decreases detection sensitivity.

#### Shock time (shock zone)

This parameter applies only when the "Shock pulses" value is more than 1.

This is the window during which a number of pulses must be detected the number of alarm pulses must equal or exceed the value programmed for "Shock pulses", before the system generates an alarm. This window can be expressed in seconds or minutes (see Note).

#### Shock pulses (shock zone)

This is the number of pulses necessary to generate a zone-alarm event.

If this value is more than 1, you must also programme the "Shock time" parameter.

If this value is 0, the zone alarm will be generated by the "Shock sensit." parameter.

All the above-mentioned values can be programmed as follows:

**If this value is expressed in minutes, there is an error margin of 1 minute (for example, if you set 5 minutes, the period can vary between 4 and 5 minutes).**

1. Use and to select whether to indicate the time in multiples of 15 milliseconds, seconds or minutes (see "info" box).
2. Use keys or to select the field you wish to change, then use the number keys (**1**., etc.) to edit the number.  
or  
Use key or to increase or decrease the number.
3. Press **OK** to confirm and exit.

### Via PC

Programming zones via the SmartLeague application is accomplished by the selection and programming of the terminal configured as zone, described in paragraph 6-5 *Terminals*.

## Outputs 6-7

This programming section deals with all the output parameters.

SmartLiving control panels provide 3 outputs:

- Relay Output
- O.C. Output 1
- O.C. Output 2

### Via Keypad

1. Access the "Outputs" section.

Type-in Code (Installer PIN) **OK**, PROGRAMMING Outputs **OK**.

2. Use and to select the output then press **OK**.

#### Description

This is the editable output label (device description). At default all the outputs, except for the 3 outputs on the control panel motherboard, assume the description of the peripheral they refer to followed by the respective terminal.

Follow the instructions in paragraph 6-6 *Zones - Descriptions*.

#### Output options

Use and to enable or disable the selected option.

- **Norm. closed:** this will be the output status during standby.
- **Monostable**
- **Buzzer (beeper):** generates a 1Khz signal when the output activates - can be used to drive a buzzer.
- **Blinker:** generates an intermittent signal (0.5 sec ON and 0.5 sec OFF) when the output activates - can be employed in direct control of a visual signaling device (e.g. flasher).
- **ON afterRestoral:** the output does not restore-to-standby (reset) when the trigger-event clears. This option is useful in situations that require a trigger event for output activation and a reset event for its deactivation.

This option applies to "Bistable" outputs only. If it is enabled for a bistable output with reset-event configuration, it will deactivate the output instead of activating it (refer to paragraph 6-9 *Events*).

This option is useful in situations that require the output to reveal event "memory" (event signaling which continues even after the event clears). In this case, the output is deactivated by a different event which restores it directly to standby (resets the output).

For example:

- O.C. Output 1 is configured as "ON afterRestoral"
- the activation of "Mains failure" event is programmed to trigger O.C. Output 1
- the restoral (reset) of "Valid code" event is programmed to trigger O.C. Output 1

In the event of Mains failure, O.C. Output 1 will activate but will not restore to standby (reset) when the Mains failure condition clears. It will restore to standby (reset) only when "CODE 1" is entered a keypad and generates a "Valid code" for the "CODE 1" event.

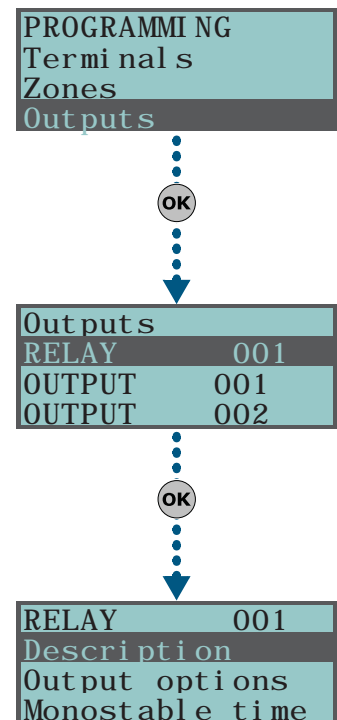

### Monostable time

This parameter applies to "Monostable" outputs only. This interval can be expressed in seconds or minutes (see "info" box).

When a "Monostable" output receives an activation signal, it will remain active (On) for the programmed time, regardless of the status of the trigger-event. In some cases, "Monostable" outputs can be forced to standby before the programmed monostable time runs out.

Use keys and and the number keys to set the times.

**If this value is expressed in minutes, there is an error margin of 1 minute (for example, if you set 5 minutes, the period can vary between 4 and 5 minutes).**

### Via PC

Programming zones via the SmartLeague application is accomplished by the selection and programming of the terminal configured as output, described in paragraph 6-5 *Terminals*.

## Telephone

## 6-8

This programming section deals with all the telephone parameters.

The built-in ATS device (alarm transmitting system) provides the following features (in compliance with EN50131 relating to the notification of information).

- Type B notification apparatus (refer to EN50131-1:2008-02, paragraph 8.6 Notification, Table 10, page 46, Grade 2).
- The ATS2 notification apparatus specified in the table, is characterized by:
  - Transmission time - classification D2 (60 seconds)
  - Transmission time - max. values M2 (120 seconds)
  - Classification time - classification T2 (25 hours)
  - Substitution security - S0 (no detection of device substitution)
  - Information security - I0 (no detection of message substitution)

### Via Keypad

Type-in Code (Installer PIN) , PROGRAMMING Telephone .

#### Select number

Use keys and to access the Phonebook which provides 10 number positions with the following programming fields.

- **Number:** edit field for the contact number (maximum 20 digits). Accepts also "," (= 2 second pause), "\*" and "#".
- **Description:** edit field for the name of the contact person. Follow the instructions in paragraph 6-6 *Zones*.
- **Type:**
  - **None** - the selected number can receive SMS text messages only
  - **Voice** - the selected number can receive voice calls and SMS text messages

If the number refers to the Alarm Receiving Centre, assigns the **ARC** protocol (reporting format):

- **Ademco 10bps**
- **Ademco 14bps**
- **Franklin 20bps**
- **Radionics 40bps**
- **Scantronic 10bps**
- **CONTACT-ID**
- **SIA** - Level 1 SIA is applied This reporting format (protocol) is capable of sending descriptions of the objects in ASCII characters. if you do not wish to send the descriptions in ASCII characters, select "No SIA strings" (refer to paragraph 6-4 *Panel options*). You can set a 4, 5 or 6 digit customer code for this protocol.
- **Ademco Express**

Use and to select the Type of number, then press .

- **Account code:** a 4-character alphanumeric code which identifies the caller in reports to the Alarm Receiving Centre. Some protocols (reporting formats) accept digits only, whilst others accept also "A", "B", "C", "D", "E" and "F", available using keys .

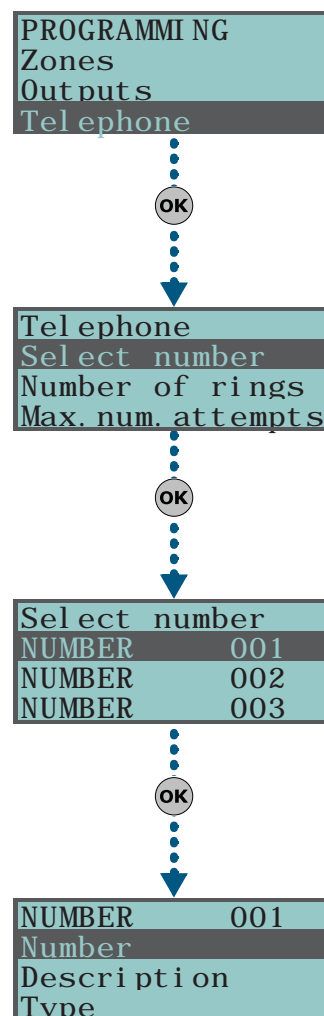

- **Partitions:** you can associate each telephone number with specific partitions. By selecting the partitions, using Keys and , you enable/disable the users (who have at least one of these partitions in common with the telephone number) to modify the number concerned.

**Number of rings**

This value determines the number of rings the system allows before picking up an incoming call.

**Max.num.attempts**

This value determines the number of calls attempts the system will make before deleting the contact number from the call queue.

**Message repeats**

This value determines the number of times the voice message will be played during the call.

All the above-mentioned values can be programmed as follows:

1. Use keys or to select the field you wish to change, then use the number keys (, etc.) to edit the number.  
or  
Use key or to increase or decrease the number.
2. Press to confirm and exit.

**Via PC**

Table 32: **Telephone - via the SmartLeague software programme**

Option	Part of the system	Template/section
Select number	SmartLiving System - Telephone	Programming
Number of rings		Parameters settings - Telephone line parameters
Max.num.attempts		Parameters settings - Telephone dialer parameters
Message repeats		

Via the SmartLeague software programme, you can enable the **“Enable to receive SMS text messages”** option which (in addition to the other signals programmed for when the event occurs) enables the telephone number to receive an SMS text message from the Nexus GSM dialer.

# Events 6-9

This programming section deals with all the event-generated output actions.

The control panel recognizes all of the events described in this paragraph and, for each them, in accordance with programming, can generate actions both when the event occurs and when it restores/ends.

The operations that can be carried out at the control panel are: output activation, event notification via telephone, save to event memory, voice message management, voice message management and management of all the options relative to each event. These actions are triggered as soon as the event occurs (or restores).

Telephone notifications (calls) are queued and sent out in chronological order. However, some events may need to be notified immediately (for example, use of a code under duress), therefore, such events can be given priority by selecting the “Priority” option.

Event notification via e-mail requires the use of a SmartLAN/G board (refer to paragraph 3-10-4 *SmartLAN*).

Event notification via predefined SMS messages requires the use of a Nexus (refer to paragraph 6-26-4 *Text for SMS messages*).

The following table shows the events the control panel recognizes, the number of events for each type, the trigger and restoral method of each event and the event category (Pulse).

Table 33: Event type

Name	Occurs when...	Restores when ...	Number of events	Pulse events
<b>Zone alarm</b>	A zone generates an alarm	A zone restores	One event for each zone	no
<b>Terminal tamper</b>	A terminal detects tamper (short-circuit or wire cutting)	A terminal restores	One event for each terminal	no
<b>Partition alarm</b>	A 24h zone which belongs to the partition generates an alarm, or a zone which belongs to the partition generates an alarm during Away mode.	All the zones belonging to the partition restore (reset).	One event for each partition	no
<b>StayPartit.alarm</b>	A zone which belongs to a partition armed in Stay or Instant mode, generates an alarm.	All the zones belonging to the partition restore (reset).	One event for each partition	no
<b>Partition tamper</b>	A zone which belongs to the partition detects tamper (short-circuit or wire cutting).	All the zones belonging to the partition restore (reset).	One event for each partition	no
<b>Zone bypass</b>	A zone is inhibited	A zone is enabled (switched On)	One event for each zone	no
<b>Real-time zone</b>	The electrical status of a zone switches from standby to alarm	The electrical status of a zone switches from alarm to standby	One event for each zone	no
	The event is independent of the zone type and the armed/disarmed status of the partitions.			
<b>Partit.not ready</b>	A zone which belongs to the partition is not in standby status.	All the zones belonging to the partition are in standby status.	One event for each partition	no
<b>Away arm request</b>	A request is made to arm the interior and perimeter zones of the partition	A request is made to disarm the partition	One event for each partition	Yes
<b>Overtime request</b>	A request is made to arm the partition in Stay mode (perimeter zones only) or in Instant mode	A request is made to disarm the partition	One event for each partition	Yes
<b>Partit.AwayArmed</b>	The partition interior and perimeter zones have been armed effectively	The partition has been disarmed effectively	One event for each partition	no
<b>Partit.StayArmed armed</b>	The partition has been armed effectively in Stay or Instant mode	The partition has been disarmed effectively	One event for each partition	no
<b>Partition reset</b>	A request is made to reset the partition		One event for each partition	Yes
<b>Exit time</b>	The partition exit time is running	The partition exit time expires	One event for each partition	no
<b>Entry time</b>	The partition entry time is running	The partition entry time expires	One event for each partition	no
<b>Pre-arm time</b>	The partition Pre-arm time is running	The partition Pre-arm time expires	One event for each partition	no
<b>Overtime request</b>	A request for overtime relating to the partition is made		One event for each partition	Yes
<b>Chime</b>	A chime zone belonging to the partition is violated		One event for each partition	Yes
<b>Forced arming</b>	At the time of an arming command, relating to one or more partitions, there are open zones on the partition/partitions involved, or there are other conditions present which lower system security, nonetheless, the user arms the system.		One event for each partition	Yes
<b>Failed to arm</b>	The "OpenZonesArmLock" option is enabled at the time of a partition arming command and there is at least one open zone on the partition/s involved. or when one or more of the conditions described in "LossTamp.ongoing" is present (refer to "FaultNotReady", paragraph 6-25 Other parameters).		One event for each partition	Yes
<b>Valid code</b>	A user-code PIN entered at a keypad is recognized as valid		One event for each code	Yes
<b>Valid key</b>	A key used at a reader is recognized as valid on the reader		One event for each key	Yes
<b>Valid Code AtKeyp.</b>	A user-code PIN entered at a keypad is recognized as valid on the keypad		One event for each keypad	Yes
<b>ValidKeyAtReader</b>	A key used at a reader is recognized as valid on the reader		One event for each reader	Yes
<b>Partition code</b>	A user-code PIN entered at a keypad is recognized as valid on the partition		One event for each partition	Yes
<b>Partition key</b>	A key used at a reader is recognized as valid on the partition		One event for each partition	Yes
<b>Failed call</b>	A call is not answered		One event for each contact telephone number	Yes
<b>Timer activated</b>	The timer is enabled (On)	The timer is disabled (Off)	One event for each timer	no
<b>Thermostat ON</b>	The activation conditions set for the keypad thermostat occur.	The deactivation conditions set for the keypad thermostat occur.	One event for each keypad	no

Table 33: Event type

Name	Occurs when...	Restores when ...	Number of events	Pulse events
<b>Scenario ON</b>	The status of all the partitions corresponds exactly to the pre-set scenario.	The status of all least one of the partitions does not correspond to the pre-set scenario.	One event for each scenario	no
<b>ProgrammableEvt</b>	See paragraph 6-9-1 Programmable events			no
<b>Emergency key</b>	One of the emergency-key duos is pressed		One event for each emergency-key duo	Yes
<b>Panel opened</b>	The control-panel enclosure cover is opened	The control-panel enclosure cover is replaced	1	no
<b>Dislodged panel</b>			1	no
<b>Zone fuse fault</b>	The zone protection fuse on the control panel is not operational (blown)	The zone protection fuse on the control panel restores	1	no
<b>IBUS fuse fault</b>	The I-BUS protection fuse is not operational (blown)	The I-BUS protection fuse restores	1	no
<b>Low battery</b>	The backup battery is low (voltage below 10.4V)	The backup battery is charged (voltage above 11.4V)	1	no
<b>Mains failure</b>	The primary 230V a.c. power source is absent (blackout)	The primary 230V a.c. power source restores	1	no
<b>Expansion tamper</b>	An expansion board signals tamper conditions	Tamper conditions clear on all the system expansion boards	1	no
<b>Keypad tamper</b>	A keypad signals tamper conditions	Tamper conditions clear on all the system keypads	1	no
<b>Reader tamper</b>	A reader signals tamper conditions	Tamper conditions clear on all the system readers	1	no
<b>Sound.flash.Tamp</b>	A sounderflasher connected to the BUS signals tamper	All the sounderflashers connected to the BUS reset	1	no
<b>Nexus tamper</b>	The GSM dialer Nexus signals tamper	Tamper conditions clear on the Nexus	1	no
<b>Expansion loss</b>	An expansion board cannot be found on the BUS	All expansion boards can be found on the BUS	1	no
<b>Keypad loss</b>	A keypad cannot be found on the BUS	All keypads can be found on the BUS	1	no
<b>Reader loss</b>	A reader cannot be found on the BUS	All readers can be found on the BUS	1	no
<b>Sound.flash.Loss</b>	A sounderflasher cannot be found on the BUS	All sounderflashers can be found on the BUS	1	no
<b>Nexus loss</b>	The control panel is unable to communicate the Nexus 100	Communication between the control panel and the Nexus restores	1	no
<b>Jamming</b>	Wireless interference detected	Wireless interference cleared	1	no
<b>Low battery WLS</b>	The battery of a least one wireless detector is running low	All the wireless detectors are running on low batteries	1	no
<b>WLS zone loss</b>	Loss of at least one wireless detector has been signaled (supervisory time-out)	All the wireless detector are present	1	no
<b>Installer code</b>	An Installer PIN entered at a keypad is recognized as valid		1	Yes
<b>Invalid code</b>	An invalid code is entered at a keypad		1	Yes
<b>False key</b>	An invalid key is used at a reader		1	Yes
<b>Nexus fault</b>	The GSM dialer Nexus signals a fault (see Chapter 7 - Errors and faults)	Fault conditions clear on the Nexus	1	no
<b>Tel. line down</b>	The land line is not working	The land line restores	1	no
<b>Periodic event</b>	The Periodic Event occurs		1	Yes
<b>Hard reset</b>	The control panel re-initializes. The system clock may be wrong or not working properly.		1	Yes
<b>Call queue full</b>	There are no more slots left in the outgoing call queue		1	Yes
<b>Successful call</b>	The call is answered		1	Yes
<b>Programming</b>	Access to system programming is authorized	End of system programming	1	no
<b>Ongoing call</b>	A call is sent	A call ends	1	no
<b>SMSMessageFailed</b>	Nexus failed to send SMS message		1	Yes
<b>Output fault</b>	An output fails to switch status as commanded		1	Yes

Each event can be associated with 3 voice messages, selected from the message list (refer to *Appendix D, Voice messages*).

- Message type
- Message A
- Message B

This feature allows you to create messages which will be played during event-related voice calls to contact numbers, both at the start and end of the event.

The choice of messages and the number of times they are played depends on the "AutomaticDialer" settings.

## Via Keypad

1. Accessing the "Events" section

Type-in Code (Installer PIN) **OK**, PROGRAMMING Events **OK**.

2. Use keys and to select the event type (if you are dealing with a group of events, repeat the operation) then press **OK**.

3. Select:

- **Activation** - to programme the actions to be carried out when the event occurs.
- **Restoral** - to programme the actions to be carried out when the event ends.

4. Successively, the parameters to programme are:

### TelephoneNumbers

Programme the call recipient numbers

### Message type

#### Message A

#### Message B

Select the number of the message (see *Table 34: Event-related messages* and *Appendix D, Voice messages*):

1. Use keys or to select the field you wish to change, then use the number keys (**1** .., etc.) to edit the number.

or

Use keys and to increase or decrease the number.

2. Press **OK** to confirm and exit.

The following table shows the voice-message sequence in accordance with the previously mentioned parameters and options.

Table 34: Event-related messages

	"Automatic dialer" enabled	"Automatic dialer" disabled
<b>Message type</b>	Plays the message relating to the event type (e.g. "zone alarm", "Mains failure") This message should not be changed.	You can select any message from 1 to 219
<b>Message A</b>	Blank message, editable	
<b>Message B</b>	Contains event details, for events which are not distinctive (e.g. the "zone alarm" event provides information regarding the zone concerned).	
<b>Event Activation Sequence</b>	1. Message type + 260 2. Message A 3. Message B 4. "Location" (244)	1. Message type 2. Message B 3. "Location" (244)
<b>Sequence in the event of Restoral</b>	1. "Restoral" (97) 2. Message type 3. Message A 4. Message B 5. "Location" (244)	1. Message A 2. Message B 3. "Location" (244)

If an event is associated with the "Automatic dialer", the "Type Message" option refers to messages 261 to 312, that is to say, the messages containing the event descriptions (event types).

### Note

### Options

To be activated by keys and :

Option	If enabled	If disabled
<b>Event ON to log</b>	When the event occurs, it will be saved to the events log.	When the event occurs, it will not be saved to the events log.
<b>Event OFF to log</b>	When the event clears, it will be saved to the events log.	When the event clears, it will not be saved to the events log.
<b>StartPeriodicEv.</b>	When the event occurs, the system will generate the Periodic event.	
<b>Silent event</b>	If the event occurs, the system will generate silent calls which will not be signaled on the keypads.	If the event occurs, the system will generate calls which will be signaled on the keypads.
<b>Clear call queue</b>	When the event occurs, the system will cancel the outgoing call queue.	
<b>Send address</b>	In the case of voice calls, the system will include the address of the location alarm (refer to the <i>Table 34: Event-related messages</i> )	In the case of voice calls, the system will not include the address of the location alarm (refer to the <i>Table 34: Event-related messages</i> )

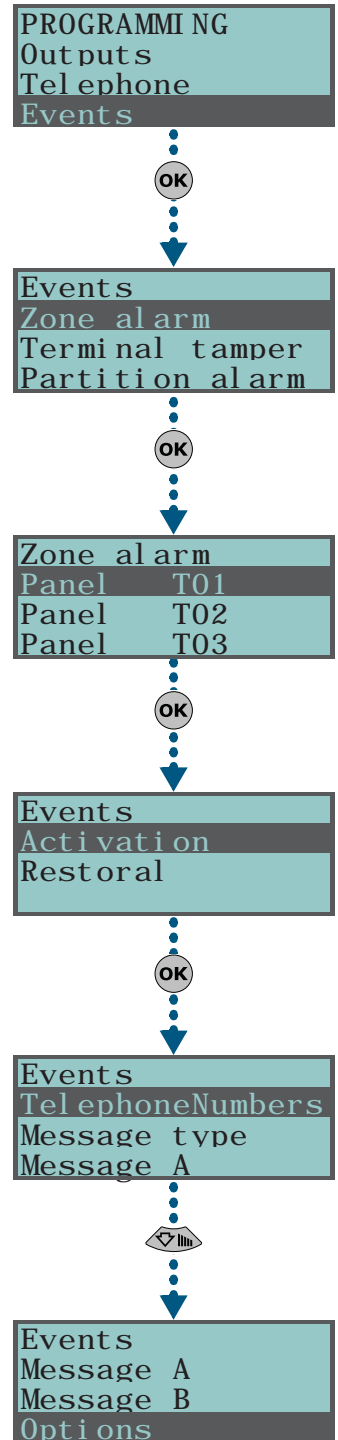

Option		If enabled	If disabled
<b>Local Message ON</b>		When the event occurs, the system will play the event-related voice message on keypad speaker n. 1	
<b>Local Message OFF</b>		When the event occurs, the system will not play the event-related voice message on keypad speaker n. 1	
<b>Automatic Dialler</b>		Refer to the <i>Table 34: Event-related messages</i>	
<b>Priority</b>		Calls associated with this type of event have priority over all other calls. Therefore, if a priority event occurs, any ongoing calls will be interrupted and the priority-event call will be sent immediately.	
<b>Switch to GSM</b>	This option is applicable only when a Nexus device is installed	All the programmed telephone calls will be managed by the Nexus	All the programmed telephone calls will be sent over the PSTN line, however, when this is unavailable (linedown, etc.), they will be managed by the Nexus
<b>Send SMS</b>		When the event occurs, the control panel will send an SMS message to all the duly enabled telephone numbers (refer paragraph 6-8 Telephone)	When the event occurs, the control panel will not send an SMS message
<b>Automatic SMS message</b>		The dispatched SMS message will consist of the event description in the Events log	The SMS text message can be selected from the 50 messages provided by the Nexus device. The SMS text message is identified by the "SMS message number/index", as described below.

**Class code**

This is the CONTACT-ID reporting format Class-Code which corresponds to the event.

**Event code**

This is the 2-character alphanumeric code, which corresponds to the event sent the alarm receiving centre (ARC). For zone and terminal events (alarm, tamper, bypass), the "CCC" field of the CONTACT-ID protocol counts the number of hard terminals in accordance with the Hard terminals table (refer to *Appendix E, Screw Terminals*).

**Outputs**

When programming the Event-Activation section, you must programme the main output which will be activated when the event occurs. When programming the Event-Restoral section, you must programme the main output which will be activated when the event ends.

Select the output from the list (which includes the Relay outputs, OC1, OC2 and the terminals configured as outputs and also the sounderflashers) and press

If the output has the "ON afterRestoral" option enabled (refer to paragraph 6-7 Outputs) and it is programmed on event restoral, the output will deactivate when the event occurs.

**Note**

For Zone alarm, Terminal tamper, Partition alarm, Stay partition alarm and Partition tamper events, monostable outputs programmed in the "Outputs" section will restore these events when, on expiry of the monostable time, the event concerned has effectively returned to standby status. If the event status restores to standby while the monostable time is running, the event itself will not be restored.

**Other outputs**

This section allows activation of added outputs (as well as the output programmed in the "Outputs" parameter) when the event occurs or restores.

These added outputs can be selected by means of keys and from a programmable list in the "Added Outputs" section.

**OtherOutputsProg**

This section allows the creation of the list of outputs (16 for "Activation" or 8 for "Restoral" to be programmed in the "Other outputs" section.

This is the sole list for the entire control panel and is independent of the type of event.

**Note**

Use keys and to select and to confirm.

**Siren sound types**

This section allows you to select the audible-visual signals emitted by the sounderflashers, when these are programmed in the "Outputs" and "Other outputs" section.

Please note that the "Tone Type" is a parameter of the event. Therefore, if several sounderflashers have been programmed in relation to a specific event, they will all emit the programmed tone when the event occurs. If a sounderflasher has been programmed in relation to several events, it will emit the last tone type setting received in order of time.

Use keys and to select and to confirm.

For further information regarding the "Outputs", "Other outputs" and "Tone type" parameters of each event, refer to *Appendix F, Combination of outputs triggered by events*.



Via PC

**SMS message number/index**

This option can be programmed solely via the SmartLeague software programme. This option is applied only when a Nexus device is installed and the "Automatic SMS" option is disabled. It determines which of the 50 available SMS messages will be sent (refer to paragraph 6-26-4 Text for SMS messages) when the event occurs.

Table 35: **Events - via SmartLeague software programme**

Option	Part of the system	Template/section
<b>TelephoneNumbers</b>	SmartLiving System - Events - select the event type	Programming
<b>Message type</b>		
<b>Message A</b>		
<b>Message B</b>		
<b>Options</b>		
<b>Class code</b>		
<b>Event code</b>		
<b>Outputs</b>		
<b>Other outputs</b>		
<b>OtherOutputsProg</b>	SmartLiving System - Events	Parameters settings - Outputs
<b>Siren sound types</b>	SmartLiving System - Events - select the event type	SmartLiving System - Siren pattern
<b>SMS message number/index</b>	SmartLiving System - Events - select the event type	Parameters settings - Nexus

**Programmable events**

**6-9-1**

A group of events is available for installer programming. Event activation and restoral depend on a combination of other control panel events based on logical operations, counters and temporizers.

On account of their enhanced flexibility, special attention is required during the programming and testing phases of the programmable events. The effects of the programmable events must always be rigorously tested.

Each programmable event consists of a structure of mathematical-logical operations, counters and temporizers. The programming structure consists of:

- 10 programmable events for SmartLiving 505 and 515 control panels, 30 for SmartLiving 1050 and 1050L and 50 for SmartLiving 10100L
- 20 temporizers
- 10 counters

Via PC

This programming process can be done only via the SmartLeague software programme. Select a programmable event from "SmartLiving System - Programmable event" from the tree menu on the left, then go to the "Parameters settings" template on the right. The Programmable event key (next to the data transfer buttons) opens a window which will allow you to define the event. This window is divided into tree sections:

**Programmable event**

This section allows you to compile the logical expression of the event. You must include all the various parameters, which may have a "real" value (either "1" or "active" - as in the case of a verified event) or a "false" value (either "0" or "not active" - as in the case of a restored event):

Table 36: **Programmable event**

<b>A</b>	Keys for the inclusion of the logical operators in the expression	
<b>B</b>	The selection field of the verified control-panel event to be included. The restoral of the event is included using the event followed by the "NOT" operator.	
<b>C</b>	The selection field of the numeric value to be included in the expression.	
<b>D</b>	Keys for the deletion of the entire expression or the last element of the expression.	
<b>E</b>	View expression field.	

## Temporizers

A temporizer is a logical expression element (it may have an "active" or "non active" value). It is characterized by an interval, therefore, you must specify an interval (in seconds) for each temporizer you wish to include.

You can select up to four "Start events" (i.e. control panel events which trigger the temporizer) and up to four "Reset events" (i.e. control panel events which interrupt the temporizer). You can specify the "Edge" for each of the eight events, that is, the status passage of the selected event ("Activation", "Reset" or "Both").

The last two options allow you to choose when the temporizer will be "active":

- **Temporizer active on Start event.** The temporizer will become "active" on start, that is, when a start event occurs, and will remain "active" for the set time. The temporizer will become "non active" when the set time expires or when a reset event occurs.
- **Temporizer active with delay.** The temporizer will remain "non active" on start, that is, when a start event occurs and will remain "non active" for the specified time. The temporizer will become "active" when the specified time expires.

---

A temporizer with the "Temporizer active with delay" option enabled will remain "active" until a reset event makes it "non active" again.

---

### Note

## Counters

A counter is a logical expression element. It is characterized by an increasing value ("Count"). The counter will have a "non active" value until it reaches the set value, which will take the counter to the "active" value.

You can select up to four "Start events" (i.e. control panel events which increase the counter value) and up to four "Reset events" (i.e. control panel events which annul the counter). You can specify the "Edge" for each of the eight events, that is, the status passage of the selected event ("Activation", "Reset" or "Both").

It is necessary to define an "Autoreset" time that will zero the count when, between two successive increases, a superior time elapses. If you do not desire an "Autoreset" time, you must set the time at "65535" (already set at default), in order to ensure that the count never expires.

---

You should not set an "Autoreset" value of less than 5 seconds.

---

### Note

Once the event programming process is complete and the event is sent to the control panel, the event programming values will be checked for errors.

If you wish to generate an alarm (i.e. activate sounderflashers and dialer calls) when only two PIRs (DET1 and DET2) go into alarm status within a pre-set time.

- T0000; temporizer 1 will activate when the "Zone alarm DET1" Start event activates for 30 seconds
- T0001; temporizer 2 will activate when the "Zone alarm DET2" Start event activates for 30 seconds
- Both conditions must occur together (AND)

T0000 AND T0001

- You must set the activation of the sounderflasher and dialer calls on a similarly-configured programmable event.
- If the programmable event activates an on-BUS sounderflasher, associate its deactivation with an event.

If you wish to activate an output for 40 seconds when key 17 is used to arm partition 1, and to disarm and the same output when the partition disarms.

- T0000; associate temporizer 1 with the activation of the Start event of key 17 recognition
- T0000; temporizer 1 with a 40 second timeout, "temporizer active with delay" option enabled
- T0000; associate temporizer 1 with the restoral of the reset event of partition 1
- Programmable event 1 must be programmed as:

T0000

- Select the output you wish to activate in concurrence with the programmable event
- If the programmable event activates an on-BUS sounderflasher, associate its deactivation with an event.

If you wish to receive a telephone call when a zone q, which belongs to partitions 1 and 2, is violated and one of the two partitions is armed

The automation zone q always generates the zone alarm event (even when the partitions are disarmed). However, the programmable event will occur only when the zone q is in alarm status and at least one of the two partitions is armed.

- Configure zone q as "automation" belonging to partitions 1 and 2
- Remove all the outputs and phone calls associated with the "Alarm zone q" event
- The programmable event must be programmed as "Alarm zone q" AND ("Partition 1 armed in away mode" OR "Partition 2 armed in away mode"):

E0010 AND ( E0790 OR E0791 )

## EXAMPLES

- Associate the programmable event with the telephone call you wish to receive

If you wish to activate a telephone call after 3 consecutive wrong code entries (with a maximum of 120 seconds between each entry).

- C0000; counter 1 will activate on activation of the "False code" Start event, with a count of 3, 120 second autoreset time
- The programmable event must be programmed as:

C0000

- Associate the programmable event with the telephone call you wish to receive

If you wish to activate a telephone call and output when at least two detectors out of 5 go into alarm status.

- The programmable event must be programmed as ("Alarm zone 1" + "Alarm zone 2" + "Alarm zone 3" + "Alarm zone 4" + "Alarm zone 5")>=2

( E0000 + E0001 + E0002 + E0003 + E0004 ) >= V0002

- Associate the programmable event with the telephone call you wish to receive and the output you wish to activate.

## Timer

This programming section deals with the 10 system Timers.

A timer can be associated with a:

- **Partition** - if a partition is associated with a timer which controls automatic-arming operations (refer to *paragraph 5-4 Attivazioni* in the *User's Manual*), it will arm when the timer switches ON and disarm when the timer switches OFF.
- **Code** - if a code is associated with a timer, it will be enabled to operate the system when the timer switches ON, and disabled when the timer switches OFF.
- **Key** - if a key is associated with a timer, it will be enabled to operate the system when the timer switches ON, and disabled when the timer switches OFF.

In order to associate timers with the partitions, codes and keys, it is necessary to access the respective control-panel programming section.

The timers must be enabled/disabled by the user (refer to *paragraph 5-4 Attivazioni* in the *User's Manual*).

When you exit the programming session (via keypad, PC or modem) all the timers will be enabled automatically, therefore, it will be necessary to reset the timers as before.

### Via Keypad

1. Accessing the "Timers" section:

Type-in Code (Installer PIN) **OK**, PROGRAMMING Timers **OK**.

2. Use keys and to select the Timer then press **OK**.
3. Using the same keys, select the day of the week.
4. Select "Activation" and/or "Restoral".

5. Use keys and to set the time (expressed in hours and minutes) and and to select the number.

6. Press **OK** to confirm and exit.

It is also possible to programme timer activation or restoral only.

If you do not wish to programme the timer activation or restoral setting, enter "--:--" in the field you do not wish to program.

### Via PC

Select an item from "SmartLiving System - Timers" from the tree menu on the left, then go to the "Parameters settings" template on the right:

The SmartLeague software programme allows you to set up 15 setting exceptions for each timer (for holiday periods, etc.).

Each "timer exception" allows you to define different On and Off times for the selected interval (1 or more days, 1 week, etc.). The pre-set times will be applied for the entire interval. The system does not accept intervals which go over the end of the year. Therefore, it is impossible to program an interval such as 12th December to 5th January. In such situations, you must program 2 "timer exceptions", one from 12th to 31st December and the other from the 1st to 5th January, both with the same On and Off settings.

## 6-10

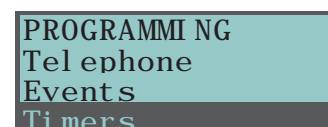

**OK**

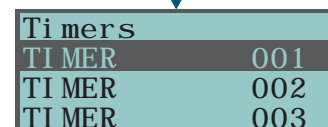

**OK**

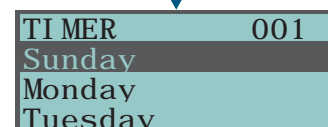

**OK**



**OK**

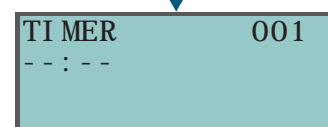

**Note**

**Note**

The exceptions have priority over the days of the week. For example, If a "timer exception", lets say 1st May, falls on a Tuesday the settings programmed for 1st May will be applied.

---

The "timer exceptions" cannot be programmed via keypad.

---

**Note**

## Partitions

## 6-11

This programming section deals with the system Partitions and the respective options and parameters.

### Via Keypad

1. Accessing the "Partitions" section:

Type-in Code (Installer PIN) **OK**, PROGRAMMING Partitions **OK**.

2. Use keys and to select the partition then press **OK**.

### Description

This is the editable partition label (description).

### Exit time

A period, expressed in minutes or seconds, during which the user must LEAVE the partition after arming the system (see the "info" box). If you set "0" in this field, there will be no Exit time (delay), therefore, any delayed zones, which belong to the partition, will generate alarms if they are not in standby status when the system arms.

### Entry time

A period (expressed in minutes or seconds) that the system allows the user to disarm the partition after violation of a delayed zone (for example, after opening the front door). If the system is not disarmed within the set time it will generate an alarm (see "info" box). If you set "0" in this field, there will be no Entry time (delay), therefore, any delayed zones will generate alarms instantly if they are violated when the system is armed.

### Pre-arm time

This is the period (expressed in minutes) before an automatic arming operation (see "info" box).

In order to comply with EN50131 instructions, the "Pre-arm" time must be set at a value that is not "0".

### Patrol time

An "Inspection" period (expressed in minutes) which allows patrol-key/code holders (security staff, night watchmen, etc.) to check the premises (see "info" box).

All the above-mentioned "times" can be programmed as follows:

1. Use keys and to choose whether to indicate the time in seconds or minutes (see "info" box)..
2. Use keys and to select the field you wish to change, then use the number keys (**1**., etc.) to edit the number.  
or  
Use keys or to increase or decrease the number.
3. Press **OK** to confirm and exit.

### Timers

Select the timer you wish to associate with the "auto-am" operations.

---

Ensure that the partition "auto-arm" option is enabled in the respective section:

Type in Code (User) **OK**, Activations **OK**.

---

Forced auto-arm operations may occur, generated by events active at the time of the auto-arm operation.

### Options

- **Auto-resetMemory** - if enabled by means of the key, each partition arming operation will reset the partition alarm/tamper memory automatically.



**If this value is expressed in minutes, there is an error margin of 1 minute (for example, if you set 5 minutes, the period can vary between 4 and 5 minutes).**

**Note**

- **Auto-arm STAYmode** - if enabled by means of the key, the partition will arm in Stay mode at the pre-set auto-arm time. If disabled by means of , the partition will arm in Away mode at the pre-set auto-arm time.
- **StopTelOn Disarm** - if enabled, the call queue will clear when the partition disarms.

### Via PC

Select an item from "SmartLiving System - Partitions" from the tree menu on the left, then go to the "Parameters settings" template on the right:

## User Codes

# 6-12

This programming section deals with the user code options/parameters.

The user code PINs must comprise 4, 5 or 6 digits. The PIN of user code n. 1 is "0001" at default. The PINs of the successive user codes are "0002", "0003", etc.

### Via Keypad

1. Accessing the "Codes" section:

Type-in Code (Installer PIN) , PROGRAMMING Codes .

2. Use keys and to select the code then press .

### Description

This is an editable programming field for the code user's name.

### Partitions

Select the partitions the user code is assigned to. Press , to enable the partition and to disable it.

### Options

Use and to enable/disable the code options.

- **Main User** - a main user can:
  - enable/disable all user codes except other Main User codes
  - change its own PIN, and the PINs of all user codes except other Main User codes

If this option is not enabled the user code will not have "Main User" status.

- **Partition filter** - if this option is enabled for codes with "Main User" status, the user will have the authority of a "Main User" only on the partitions it is assigned to. For example, if a code is configured as "Main User" with Partition filter and is assigned to partitions 1, 3, 5 and 7, it will be able to enable/disable and change the PINs of all user codes but not Main User codes assigned to these partitions.
- **Text menu and User menu** - the combination of these two options allows instant access to the respective menus (the menu screens appear instantly on the keypad display) when the user PIN is typed-in at a keypad and is pressed. Refer to the following table.

Case	Text menu	User menu	Description
A	Disabled	Enabled	Accesses the standard user-menu; at this point the user can scroll the list using  and  and select the required option.
B	Disabled	Disabled	Shows the personalized user-icons associated with function keys <b>F1</b> , ..., <b>F4</b> ; at this point the user can press the required function key and activate the respective shortcut.
C	Enabled	Disabled	Shows the descriptions of the personalized user-ions associated with function keys. instead of the shortcut icons. The user can use  and  to scroll the list and select the shortcut, which can be activated by means of the  key.
D	Enabled	Enabled	The same as "C"

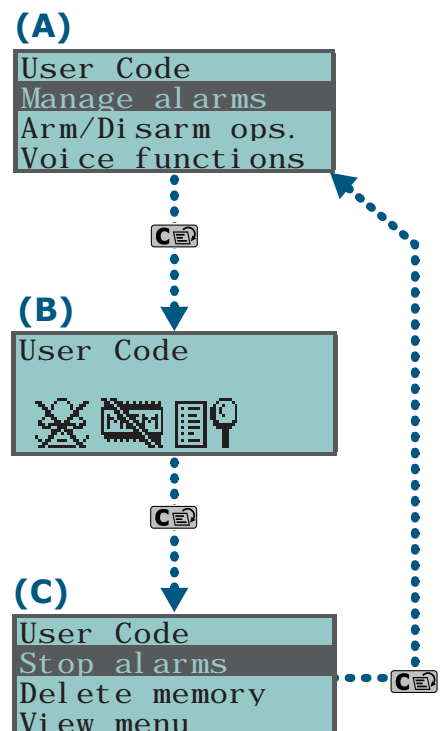
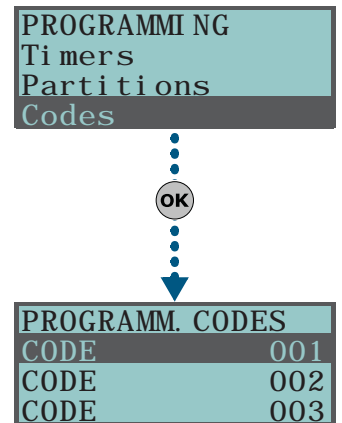

### Note

In all methods of access (A, B and C), the key allows you to access/view the other cases in succession, see figure.

- **AnnounceShortcut** - (for JOY/MAX keypad only) if enabled, after PIN entry followed by **OK**, the voice guide will announce the available shortcuts for the user-code concerned and the respective number keys on the keypad.

Set the "Loc.KpadMess Time" (refer to paragraph 6-25 *Other parameters*) to allow the system to play the messages associated with all the shortcuts assigned to number keys **0**, ..., **9**.

- **Remote access** - if enabled, the code PIN can be used to operate the system from any remote telephone.

If the code PIN is entered on a remote telephone keypad, only the shortcuts associated with keys 0 to 9 can be used to:

- Arm/Disarm
- Stop alarms
- Clear call queue
- Delete memory
- Activate outputs
- Deactiv. outputs
- Listen-in
- Arming status

Any other type of command will have no effect.

- **Patrol** - if enabled, the code will be able to disable the system for the pre-set "Patrol time".





### Func.KeyShortcuts

This section allows you to programme up to 12 shortcuts associated with keys **F1**, ..., **F4**. After valid PIN entry followed by **OK**, the keypad will show the icons that correspond to shortcut keys **F1**, ..., **F4**. Press the corresponding key to activate the respective shortcut.

### 0/9 Key shortcuts





This section allows you to programme up to 10 shortcuts associated with keys **0**, ..., **9**. After valid PIN entry followed by **OK**, the user will be able to activate specific shortcuts by means of the number keys.

To assign the shortcuts to the function keys, work through the following steps.

1. Use key  or  to select the key you wish to associate with the shortcut then press **OK**.
2. Press **OK** then use key  or  to select the shortcut you wish to associate with the key from the "Type" list.
3. Press **OK** to confirm and exit.
4. If the shortcut is associated with "Arm/Disarm" operations, the application will ask you to select a scenario. If the associated shortcut is "Activate outputs" or "Deactiv. outputs", the application will ask you to select an output.

### Assigned outputs

This section allows you to enable/disable the outputs the code user can control manually via the **User Menu>Outputs ON/OFF**.

1. Use keys  and  to select the desired output.
2. Use keys  and  to enable/disable manual control of the output for the code concerned.
3. Press **OK** to confirm and exit.

### Timers

This section allows you to assign a timer to the code. The code will be operative only at the pre-set times.

### Enable/disable

This section allows you to enable/disable access to the various sections of the User Menu.

For further details regarding the User Menu, refer to the "User Menu" section.

The programming steps are identical to those of "Outputs ON/OFF".

## Note

### Via PC

Select an item from "SmartLiving System - Users - Codes" from the tree menu on the left, then go to the "Parameters settings" template on the right.

## Installer codes

This section allows you to programme the functions of the 2 installer codes. The user code PINs must comprise 4, 5 or 6 digits.

### Via Keypad

Type-in a valid code (Installer) **OK**, PROGRAMMING Installer code **OK**.

#### ChangeInst. PIN 1

For security reasons, you must change the PIN of the primary installer code (type-in twice). The PIN is "9999" at default.

#### ChangeInst. PIN 2

For security reasons, you must change the PIN of the secondary installer code (type-in twice). The PIN is "9998" at default.

#### Inst.code2Access

Use **[\*]** and **[#]** to enable/disable the Installer-Menu sections the secondary installer code can access.

In this section, the secondary installer code can access Inst.CodePIN2 section only.

## 6-13

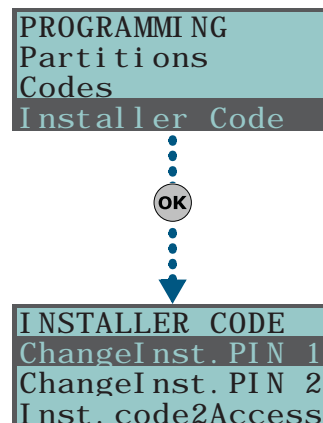

### Note

## Keys

This section will allow you to programme the parameters of the digital keys and Air2-KF100 wireless keyfobs (for details regarding the wireless keyfobs, refer to the Air2-BS100 Transceiver Installation guide).

### Via Keypad

Type-in Code (Installer PIN) **OK**, PROGRAMMING Keys **OK**.

#### Enroll

Each digital key and wireless keyfob must be enrolled separately on the system in order to allow it to operate. The enrolling procedure is as follows.

1. View the readers in the control panel configuration. Select the reader you wish to use in order to enroll the key/s, then press **OK**. If you select a reader simulated by the Air2-BS100, a "W" will be shown at the end of the description.
2. Select the digital key you wish to enroll and press **OK**. If you are using an nBy/S or nBy/X reader, all the LEDs will begin to blink to indicate that it is ready to enroll the key.
3. The keypad will indicate the current description of the digital key concerned.
4. Hold the digital key in the vicinity of the reader and then move it away. For Air2-KF100 wireless keyfobs, press contemporarily keys 3 and 4.
5. The keypad will emit a beep to confirm that the digital key has been successfully enrolled. If you are using an nBy/S or nBy/X reader, the red LED will go On. The digital key description will go to the next key automatically. This method (from step 4.) allows you to enroll as many digital keys as the system requires.
6. Once you have completed the enrolling process, press **Esc** or **C**.

All the enrolled keys will be enabled to operate the system immediately.

## 6-14

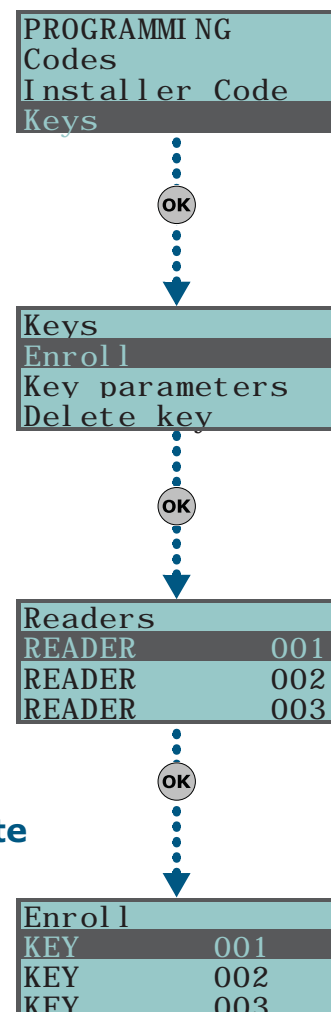

### Note

## Key parameters

This section allows you to programme all the parameters of the selected digital key.

- **Description** - editable field for the name of the digital key user.
- **Partitions** - the partitions the digital key is assigned to and therefore can control.
- **Options** - activated by means of keys and , are:

Option	If enabled	If disabled	
<b>Patrol</b>	The digital key will be able to disarm specific partitions for patrol purposes.		
<b>Maintenance</b>	The digital key will be able to block alarm/tamper outputs for the time that it is held in front of a reader.		
<b>Use keyShortcuts</b>	If a digital key is held in the vicinity of a reader, only the digital key shortcuts will be indicated, and not the reader shortcuts.	If a digital key is held in the vicinity of a reader, only the reader shortcuts will be indicated and, if configured, the first shortcut programmed on the digital key.	<b>These options do not apply to Air2-KF100 wireless keyfobs.</b>
<b>DisarmNotAllowed</b>	If a digital key is held in the vicinity of a reader when partitions are armed, the Disarm option will be inhibited (all LEDs Off).	If a digital key is held in the vicinity of a reader when partitions are armed, the Disarm option will be allowed (all LEDs Off).	

- **Timers** - this section allows you to associate a timer with the digital key. The key will be able to operate the system only when the associated timer is "On".
- **Shortcuts** - this section allows you to programme up to 4 shortcuts (F1, F2, F3, F4) for each key.

The shortcut associated with the key can be one of the following types:

- None
- Arm/disarm
- Stop alarms
- Clear Call Queue
- Delete memory
- Activate Output
- Deactiv. outputs
- Overtime
- Teleservice req.
- Voice guide

If a digital key is held in the vicinity of an nBy/S or nBy/X reader, the LEDs will run through a series of visual signals with the following meanings:

LED indicator sequence		Option: Use keyShortcuts	
		enabled	disabled
<b>1</b>	Red LED On	Digital key shortcut F1	shortcut associated with the red LED on the reader
<b>2</b>	Blue LED On	Digital key shortcut F2	shortcut associated with the blue LED on the reader
<b>3</b>	Green LED On	Digital key shortcut F3	shortcut associated with the green LED on the reader
<b>4</b>	Yellow LED On	Digital key shortcut F4	shortcut associated with the yellow LED on the reader
<b>5</b>	All LEDs On	This sequence does not occur	Digital key shortcut F1
<b>6</b>	All LEDs Off	Option: DisarmNotAllowed	
		enabled	disabled
		No request to arm ALL the partitions common to both the key and reader.	Request to arm ALL the partitions common to both the key and reader.

## Delete key

This section allows you to delete enrolled digital keys from the system configuration. The enrolled digital keys can be found in the list with the symbol.

1. Use or to select the digital key you wish to delete.
2. Press to delete the selected digital key.
3. Press to confirm and exit.

## Enable/disable

This section allows you to enable/disable the digital keys:

1. Use or to select the digital key you wish to enable/disable
2. Use keys or to enable/disable the selected digital key.
3. Press to confirm and exit.

## Via PC

Select an item from "SmartLiving System - Users - Digital keys" from the tree menu on the left, then go to the "Parameters settings" template on the right.



## Arming scenarios

### 6-15

This section allows you to configure up to different 30 arming scenarios.

#### Via Keypad

1. Access "Arming scenarios" section.

Type-in Code (Installer) **OK**, PROGRAMMING Arming scenarios **OK**.

2. Use keys or to select the scenario then press **OK**.

#### Description

Editable field for the description of the scenario.

#### Icon

This section allows you to select the icon you wish to assign to the scenario, simply by indicating the icon number (refer to *Appendix B, Shortcuts at default*):

1. Use keys or to scroll across the digits.
2. Use the number keys (**1**., etc.) to edit the number.
3. Press **OK** to confirm and exit.

The "Arm" shortcut associated with function key **F1 Fn** to **F4** will use (reveal) the icon selected in this section.

#### Partitions

This section allows you to configure the scenarios of all the partitions managed by the various models.

1. Use keys or to select the partition, then press **OK**.
  2. Use keys or to select the operating mode (Away, Stay, Disarm, etc.).
- **None** - the current operating mode of the partition will not be changed.
  - **Away** - the partition will arm in Away mode (interior and perimeter).
  - **Stay** - the partition will arm in Stay mode (perimeter only).
  - **Instant** - the partition will arm in Instant mode (perimeter only with zero delay).
  - **Disarm** - the partition will disarm.

#### Output

Each scenario, when applied, can activate one output (via keypad, at reader, over-the-phone, etc.). Use or to select the output then press **OK**.

It is possible to use a scenario to activate an output. This can be done through the Scenarios section by simply leaving the respective "Partition" programming fields free (None), thus allowing the association of the Icons with the outputs.

3. Press **OK** to confirm and exit.

#### Via PC

Select an item from "SmartLiving System - Scenarios" from the tree menu on the left, then go to the "Parameters settings" template on the right.

## Shortcuts

### 6-16

This section allows you to create up to 36 different shortcuts.

#### Via Keypad

1. Accessing the "Shortcuts" section:

Type-in Code (Installer PIN) **OK**, PROGRAMMING Shortcuts **OK**.

2. Use keys or to select the shortcut then press **OK**.

#### Description

This is the editable label which identifies the shortcut.

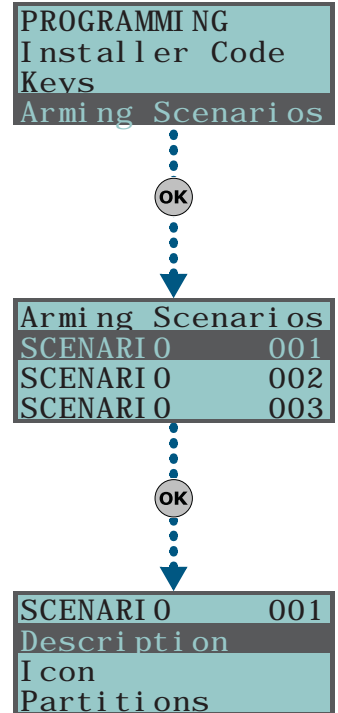

#### Note

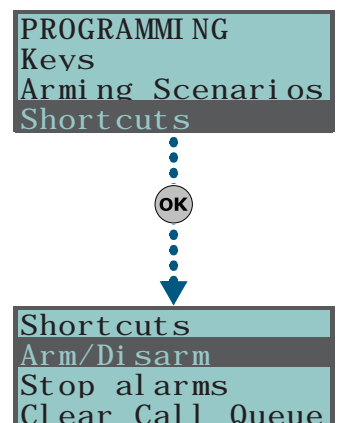

**Icon**

This section allows you to select the icon you wish to represent the scenario, simply by indicating the icon number (refer to *Appendix B, Shortcuts at default*):

1. Use keys or to scroll across the digits.
2. Use the number keys ( , etc.) to edit the number.
3. Press to confirm and exit.

**Via PC**

Select an item from "SmartLiving System - Shortcut icons" from the tree menu on the left, then go to the "Parameters settings" template on the right.

**Expansions**

This section allows you to programme the parameters of the expansions.

**Via Keypad**

Type-in Code (Installer PIN) , PROGRAMMING Expansions .

**Enable/disable**

This section allows you to add/remove expansions from the I-BUS configuration, by means of keys and .

**ChoosePeripheral**

This section allows you to edit the description of each expansion board.

**Via PC**

Table 37: **Expansions - via SmartLeague software programme**

Option	Part of the system	Template/section
Enable/disable	/	Project
ChoosePeripheral	Expansions - select the expansion	Programming

**6-17**

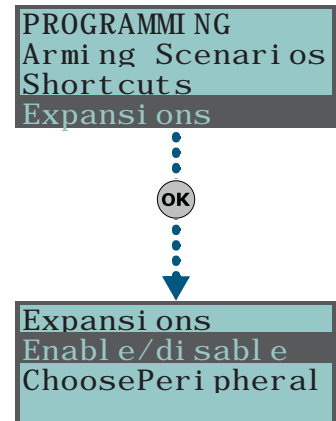

**Keypads**

This section allows you to programme the parameters of the keypads.

**Via Keypad**

Type-in Code (Installer PIN) , PROGRAMMING Keypads .

**Enable/disable**

This section allows you to add/remove expansions from the I-BUS configuration, by means of keys and .

**ChoosePeripheral**

This section allows you to programme the various options of the selected keypad.

- **Description** - editable field for the name of the digital key user.
- **Partitions** - use and to enable/disable the keypad on the system partitions.
- **Options:**
  - **Temperature off** - if this option is enabled, the room temperature will be flashed in alternation on the display. This option applies to JOY/MAX keypads only.
  - **SilentExitTime** - enable/disable the buzzer during partition Exit Time.
  - **SilentEntryTime** - enable/disable the buzzer during entry partition Entry time
  - **SignalExitTime** - enable/disable the buzzer when terminal T1 on the keypad is activated as an output.
- **Func.KeyShortcuts** - shortcuts assigned to keys **F1 Fn** , ... , **F4 Fn** . Function keys F1 to F12 must be selected separately and programmed as follows:
  - **Type** - this is the shortcut action which can be selected from those available (refer to *Appendix B, Shortcuts at default*). It is necessary to programme an extra parameter for some shortcuts:
    - "Arm/disarm", this parameter refers to one of the 30 scenarios

**6-18**

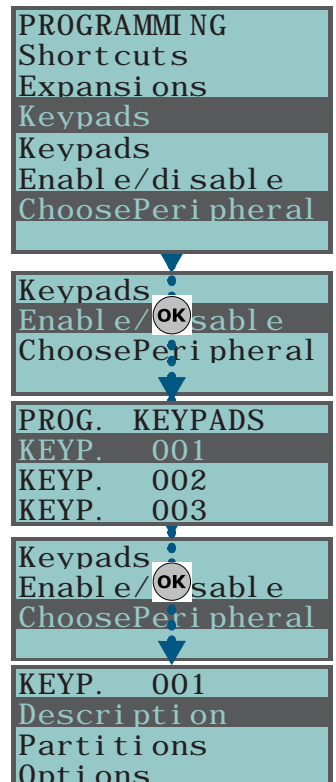

- "Activate outputs", this parameter refers to the output that will be deactivated
- "Deactiv. outputs", this parameter refers to the output that will be deactivated

The "Listen-in" and "Arming status" will have no effect if the respective command is entered at a keypad.

- **Options** - activated by means of \* and #:
  - **Requires code** - if enabled, the system will ask for user-code entry before activating the shortcut. If the system recognizes the entered user code, it will activate the shortcut command.
  - **SecurityRiskCode** - if you enable this option, you must also enable the "Requires code" option. When this option is enabled and the selected shortcut involves a scenario that completely disarms a partition, or switches a partition from Away mode to Stay mode, the security of your system will obviously be at risk, therefore, the system will request code entry.
  - **Confirm** - if enabled, the system will ask the user for confirmation (press **OK**) before activating the function-key shortcut. This method draws the users attention to requested operations that do not require codes, and thus avoids accidental arm/disarm operations, etc.

Via PC

Table 38: Keypads - via SmartLeague software programme

Option	Part of the system	Template/section
Enable/disable	/	Project
ChoosePeripheral	Keypads - select the keypad	Programming

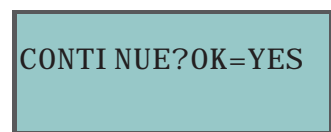

## Readers

## 6-19

This section allows you to programme the reader options.

Via Keypad

Type-in Code (Installer PIN) **OK**, PROGRAMMING Readers **OK**.

### Enable/disable

This section allows you to add/remove readers to the I-BUS configuration, by means of keys \* and #.

This is a reader simulated by the Air2-BS100, a "W" will be shown at the end of the description.

### ChoosePeripheral

This section allows you to programme the various options of the selected reader.

- **Description** - editable field for the name of the digital key user.
- **Partitions** - use \* or # to enable/disable the reader on the system partitions.
- **Shortcuts** - this section allows you to programme the shortcuts associated with the 4 differently-coloured LEDs on the reader. In order:
  - Red LED shortcut
  - Blue LED shortcut
  - Green LED shortcut
  - Yellow LED shortcut

The shortcut associated with the LED can be one of the following types:

- None
- Arm/Disarm
- Stop alarms
- Clear call queue
- Delete memory
- Activate outputs
- Deactiv. outputs
- Overtime
- Teleservice req.
- View faults

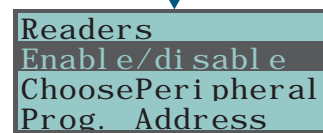
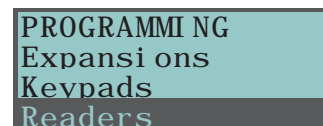

### Prog. Address

This section allows you to activate the enrolling phase and programme the addresses of nBy/S and nBy/X readers.

Follow the instructions for addressing readers in paragraph 3-3-3 Addressing nBy readers.

#### Via PC

Table 39: Readers - via SmartLeague software programme

Option	Part of the system	Template/section
Enable/disable	/	Project
ChoosePeripheral	Proximity readers - select the reader	Programming
Prog. Address	Proximity readers	Programming

## Sounders

## 6-20

This section allows you to programme the parameters of the sounderflashers connected to the IBUS.

#### Via Keypad

Type-in Code (Installer PIN) , PROGRAMMING Sounders .

#### Enable/disable

This section allows you to add/remove sounderflashers from the I-BUS configuration, by means of keys and .

#### ChoosePeripheral

This section allows you to edit the description of each sounderflasher.

#### Via PC

Table 40: Sounderflashers - via SmartLeague software programme

Option	Part of the system	Template/section
Enable/disable	/	Project
ChoosePeripheral	Sounders - select the sounder/flasher	Programming

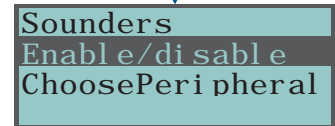
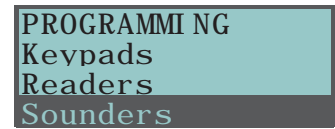

## 6-21

## Language

#### Via Keypad

This option allows you to select the language the system uses in the User and Installer menus (fault/alarm descriptions, etc.). However, the edited descriptions of the various system elements such as: zone, partitions, outputs, codes, descriptions will remain unchanged.

Use keys or to select the desired language and to confirm.

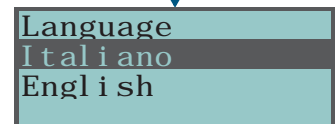
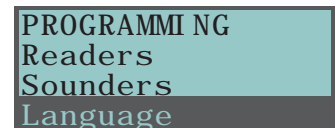

## Messages

This section allows you to record (and playback) all the voice messages. The Table in the Appendix shows all the pre-recorded messages provided by the SmartLogos30M voice board.

### Via Keypad

1. Accessing the "Messages" section:

Type-in Code (Installer PIN) **OK**, PROGRAMMING Messages **OK**.

2. Use keys or to select the field you wish to change, then use the number keys (**1**., etc.) to edit the number.

or

Use keys or to increase or decrease the number.

3. Press **OK**.
4. Use or to select the instructions for the selected message then press **OK**.

### Record

Before recording a voice message, you must first select:

- **No Message** - no recording or playback
- **High quality** - for superior recording/playback quality
- **Average quality** - for good recording/playback quality (similar to phone-line quality).

High quality messages occupy twice the memory space of average quality messages of the same length.

The recording will start when **OK** is pressed, the running recording time (seconds) will be indicated by a second-counter on the keypad display. If you wish to interrupt the record/playback operation manually press **OK**, otherwise, it will end automatically when the pre-set time-out expires.

### Play

Message playback section. You can adjust the volume during the playback phase using keys and .

### Delete

Delete message section. The control panel will ask for confirmation before deleting the message, by means of the (**OK**) key.

### Via PC

The Parameters settings template of the "SmartLiving System - Announcements" will allow you to:

- upload all the voice messages
- download all the voice messages
- format voice board

Select an item from "SmartLiving System - Announcements" from the tree menu on the left, then go to the "Parameters settings" template on the right and programme the selected message.

## 6-22

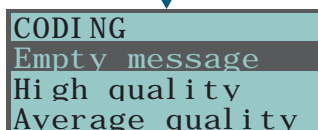
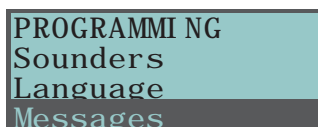
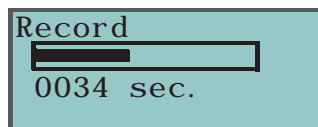

## Default settings

This section allows you to reset to default settings all the control panel parameters, auto-learn zone balancing values, auto-enroll I-BUS peripherals and restore the event codes of CONTACT-ID reporting format.

Reset to default can be carried out at a keypad via the installer menu (details follow), or via the control panel motherboard, using the following procedure.

1. Disconnect all power to the control panel (Mains and and battery power).
2. Short-circuit terminals "2" and "3" of the serial cable connector (refer to *Table 4: Control panels - description of parts, S*).
3. Power-up the control panel and maintain the short-circuit condition on terminals "2" and "3" for at least 5 seconds.

## 6-23

Serial port

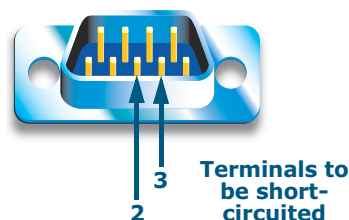

4. Restore the short-circuit condition.

Within 70 seconds the control panel will reset to default settings, re-enroll all the peripherals currently on the I-BUS and, if a keypad is connected, will ask you to select the Language.

Reset to factory default will not clear the events log.

### Via Keypad

1. Access the "Default settings" section:

Type in Code (Installer) **OK**, PROGRAMMING Default settings **OK**.

2. Use keys or to select the function then press **OK**:

#### Factory data

If you select this option, the control panel will reset entirely to default settings.

**This operations deletes all the previously programmed parameters.**

#### Learn zone bal.

If you select this option, the control panel will learn (save to memory) automatically all the balancing settings of all the zones (**Patent Pending**).

The zone-balancing options are:

- Normally Open
- Normally Closed
- Balancing (Single balancing)
- Double balancing
- Rollerblind with EOL

The balancing settings which are not acquired accurately are:

- Rollerblind without EOL (which is classified as a normally-closed generic zone)
- Double zone without EOL (which is classified as a normally-closed generic zone)
- Double zone with EOL (which is classified as a generic zone with Double balancing)

In order to allow accurate acquisition of the balancing settings of all the zones, you must:

- Wire and select the balancing settings of all the zones.
- Ensure that all the zones are in standby status
- Select the "Learn zone bal." option.
- Verify that the operation has been carried properly and that all the settings are accurate (if any zones are not in standby status during this process their settings will not be acquired accurately).
- Set manually any inaccurate settings.

#### Auto enrol Periph

If you select this option, the control panel will enroll automatically all the peripherals it finds on the I-BUS.

#### CONTACT-ID only

If you select this option, the control panel will reset to default settings all the event codes used for the CONTACT-ID reporting format.

#### DeletePrg.events

Press the **OK** key to delete all the events saved to the control panel events log (activation and restoral events):

- All outputs
- All calls
- All options

#### WLS data reset

Press the **OK** key to delete all the data relating to the Air2-BS100 device.

The data relating to the wireless detectors and keyfobs will not reset on the control panel, nor will the devices simulated by the Air2-BS100 transceiver be deleted from the configuration.

3. The control panel will ask for confirmation of this command (press **OK**).

### ATTENTION!

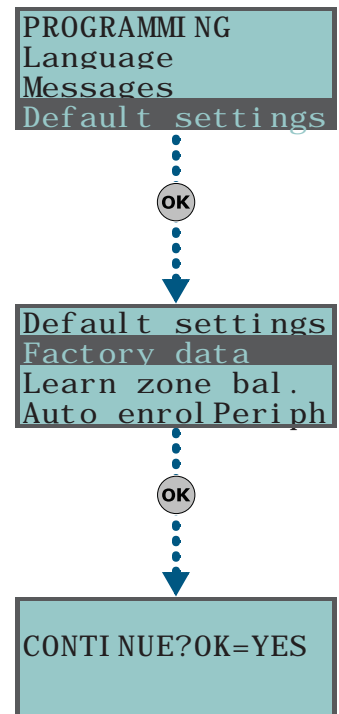

### Note

## User functions

## 6-24

This section describes the functions the installer has in common with the user.

### Via Keypad

1. Access the "User functions" section:

Type-in Code (Installer) **OK**, PROGRAMMING User functions **OK**.

2. Use keys and to select the User functions then press **OK**.

#### View

- **Events log** - allows you to view all the events saved to the log.
- **Alarms log** - allows you to view all the events relating to zone/partition alarm and tamper saved to the log.
- **Faults log** - allows you to view all the fault events saved to the log.
- **Arm/Disarm ops.** - allows you to view all the arm/disarm operations saved to the log.

Use key or to scroll the chronological events list. For some events, key allows you to view the partitions details. For example, the details of an "Arm" command will show the code and keypad concerned and, if you press , the list of partitions involved.

- **Nexus status** - allows you to view (on the display) the following parameters of the Nexus device:
  - 1° line: GSM network provider (Vodafone, etc.)
  - 2° line: GSM signal reception (value between 1 and 100)
  - 3° line: balance, at the last operation (expressed in the local currency)
  - 4° line: faults present; if faults are present, access the "View-Faults" section for details.
- **System voltage** - allows you to view the voltage the system uses.
- **Zone status** - allows you to view the status of all the zones. Use key or to scroll the list of accessible zones.  
The "Zone status" section allows you to view the zone status ("Standby", "Alarm", "Shorted", "Tamper"), the operating status (Unbypassed - able to generate alarms, or Bypassed - unable to generate alarms) and also the resistor value expressed in Ohm.
- **Faults** - allows you to view any current faults.
- **Panel version** - allows you to view the firmware version and model of the SmartLiving control panel.

#### Outputs ON/OFF

Allows manual activation/deactivation of the outputs by means of keys and .

#### Set date/time

Allows you to set the date and time of the control panel.

1. Use key or to select the programming field you wish to change (hour, minutes, etc.).
2. Use key or to change the value in the selected field.
3. Press **OK** to save and exit.

### Via PC

Table 41: **User functions - via SmartLeague software programme**

Option	Part of the system	Template/section
<b>View/Log</b>	SmartLiving system - Log	Programming
<b>Set date/time</b>	SmartLiving System	Programming

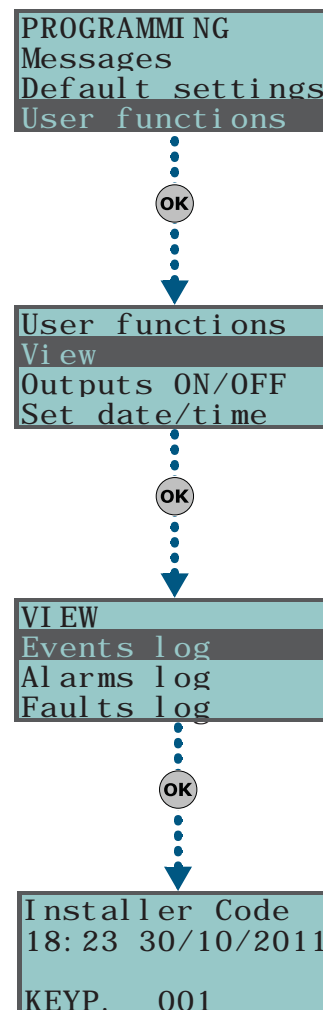

## Other parameters

## 6-25

This option allows you to programme the advanced functions of the control panel.

### Via Keypad

1. Access the "Other parameters" section.

Type-in Code (Installer PIN) **OK**, PROGRAMMING Other parameters **OK**.

2. Use key  or  to select the parameter then press **OK**.

### Periodic event

This parameter allows you to set the time (hh/mm), day, month and year of the first "Periodic event" (refer to paragraph 6-9 *Events*).

The time/date setting of this parameter must be later than the control panel clock setting.

### PeriodicInterval

This parameter allows you to set the interval between "Periodic events" (expressed in hours).

To disable the "Periodic event", set "0".

### Mains fail.Delay

This parameter allows you to programme the delay, expressed in minutes (see "info" box), between mains failure and the "Mains failure" fault event signal.

### LockpadMessTimes

The number of times messages, relating to the events recorded on the keypad, will be played (JOY/MAX keypads only).

The playback phase can be stopped by pressing any key. If you set a value of "255" the playback can be stopped by pressing any key, this is the only method of stopping playback.

### OverThePhoneVol.

This is the volume of the voice messages over-the-phone.

### Ring sensitivity

This value determines the reception sensitivity of incoming call rings. This option is useful in situations of bad reception (break up) or noisy lines.

At default this value is set at 50. Accepted values: 1 to 100. The higher the value the higher the sensitivity.

### Wireless superv.

This value determines the wireless-detector supervision time. Once the pre-set time expires, the detectors which do not respond will be signaled as lost. Accepted values: 12 to 250 minutes.

### Tel. input gain

This value determines the volume of the incoming call signal. This option is useful in situations which require better comprehension of DTMF tones and improvement of teleservice intervention via modem.

### Adj. temperature

This parameter will allow you to enter the effective value of the room temperature read by an external thermometer. This value will replace the keypad temperature reading and thus allow you to correct the temperature sensor on the keypad you are working on (Joy/MAX only).

The entered value must be expressed in °C decimals (for example, type in 25.2 if the temperature is 25.2 °C).

### LowBattery delay

This parameter allows you to programme the delay, expressed in minutes, which will be applied before "LowBattery" events are signaled.

### LinedownDelay

This parameter allows you to programme the delay, expressed in seconds, which will be applied before signaling of "LineDownDelay" events occurs.

All the above-mentioned parameters can be programmed as follows.

### Note



**If this value is expressed in minutes, there is an error margin of 1 minute (for example, if you set 5 minutes, the period can vary between 4 and 5 minutes).**

```
OverThePhoneVol .
00 Units
(Min. 010)
(Max. 100)
```

```
Tel. input gain
00 Units
(Min. 001)
(Max. 080)
```



**If this value is expressed in minutes, there is an error margin of 4 minutes (for example, if you set 7 minutes, the period can vary between 3 and 7 minutes).**



3. Use key or to select the field you wish to change, then use the number keys (**1** .., etc.) to edit the number.

or

Use key or to increase or decrease the number.

### FaultNotReady

This section allows you to select which events, other than zones in alarm status, will be signaled as system security-risk conditions when the partition arms.

Following are the events which can be enabled/disabled by means of keys \* and #:

- Zone fuse fault
- IBUS fuse fault
- Low battery
- Mains failure
- Tel. line down
- Jamming
- Low battery WLS
- WLS zone loss
- LossTamp.ongoing

The last item groups the following events:

- Panel opened
- Dislodged panel
- Expansion tamper
- Keypad tamper
- Reader tamper
- Sound.flash.Tamp
- Nexus tamper
- Expansion loss
- Keypad loss
- Reader loss
- Sound.flash.Loss
- Nexus loss

4. Press to confirm and exit.

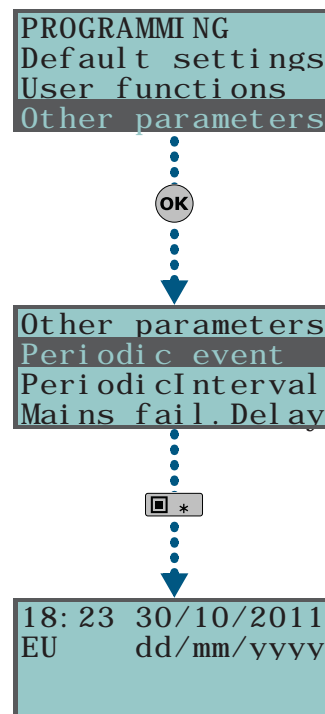

### Via PC

Table 42: Options - via SmartLeague software programme

Option	Part of the system	Template/section
<b>Periodic event</b>	SmartLiving System	Parameters settings - periodic event
<b>PeriodicInterval</b>		Parameters settings - I-BUS parameters
<b>Mains fail.Delay</b>		Parameters settings - Keypad parameters
<b>LockpadMessTimes</b>	Keypads	Parameters settings - Telephone options
<b>OverThePhoneVol.</b>	SmartLiving System	Parameters settings - Telephone line parameters
<b>Ring sensitivity</b>	SmartLiving System - Telephone	Parameters settings - Control panel parameters
<b>Wireless superv.</b>	SmartLiving System	Parameters settings - Telephone options
<b>Tel. input gain</b>		Parameters settings - I-BUS parameters
<b>LowBattery delay</b>		Parameters settings - Telephone dialer parameters
<b>LinedownDelay</b>	SmartLiving System - Telephone	Parameters settings - 50131 Parameters
<b>FaultNotReady</b>	SmartLiving System	

## Telephone line adjustment

## 6-25-1

The "OverThePhoneVol." and "Tel. input gain" parameters can be used to correct the voice functions of the dialer and the DTMF tones. The values of these parameters affect each other, therefore, and a good result is always a compromise.

If you are not using a GSM interface, you should:

- Adjust one parameter at a time and carry out tests to verify the result.
- Increase/decrease the values in small steps (for example, from 25 to 22 and not from 25 to 15).
- If the DTMF tones are not recognized, or are recognized with difficulty, decrease the value of the "Volume Tel.voice" parameter (in small steps of 2 or 3 units) and verify the effect. If there is no improvement, increase the value of the "VolumeTel. In." parameter until an acceptable combination is achieved.  
Do not increase the "VolumeTel. In" parameter excessively, as an excessive value may cause incorrect interpretation of DTMF tones.
- If the volume of the telephone messages is low, increase the "Volume Tel.voice" (in small steps of 1 or 2 units) and verify the effect. An excessive value of the "Volume Tel.voice." parameter may cause incorrect interpretation of DTMF tones.

In most cases, the value of the "Volume Tel.voice" parameter is between 15 and 25, whereas, the value of the "VolumeTel. In." parameter is between 20 and 30.

If you are not using a SmartLink GSM interface, you should:

- If the DTMF tones are not recognized, or are recognized with difficulty, increase the value of the SmartLINK "VolumeTel.In" parameter by 1 or 2 notches over the medium value "M" then verify the effect. If there is no improvement, decrease the value of the "VolumeTel.In." parameter of the SmartLiving control panel until an acceptable combination is achieved..

Any changes to the value of the SmartLink "VolumeTel.In." parameter come into effect almost 2 minutes after the setting change, therefore, you must allow this time to pass before verifying the effect.

### Note

## Programming the Nexus

## 6-26

The Nexus programming phase allows you to select which actions the control panel will implement on receiving a voice call/SMS message (from an authorized user) over the GSM network. Each command comprises a group of fully-programmable parameters.

Each time a user requests an operation - via a correctly formatted SMS message or voice call to the SIM card of the Nexus - the control panel will activate the respective shortcut/event and send confirmation (feedback) of the successfully implemented command.

The following parameters can be programmed solely via the SmartLeague software programme. Select the "Nexus" item from the SmartLiving system layout (on the left) and then go to the "Programming" section on the right to programme the relative parameters.

### SMS Commands

### 6-26-1

The "Programming - SMS Commands" section allows you to programme up to 30 SMS-activated commands.

- **Action** - this identifies the number of the command in the table displayed.
- **SMS Text** - this is an identification string for SMS message command.
- **Shortcut** - this field will allow you to select one of the following shortcuts:
  - Arm/Disarm
  - Stop alarms
  - Clear call queue
  - Delete memory
  - Activate outputs
  - Deactiv. outputs
  - Balance enquiry - this command (which is not a control-panel shortcut command) generates a balance enquiry relating to the SIM inside the Nexus (refer to paragraph 6-26-3 *General parameters*)
  - Status - this command (which is not a control-panel shortcut command) generates a status enquiry relating to the Nexus (refer to paragraph 6-26-3 *General parameters*)

### PANEL OPTIONS

- Inhibit (bypass) control panel zones
- Activate (unbypass) control panel zones
- **Shortcut option** - field for the selection of the parameter relating to the shortcut.
- **Shortcut 2** - field for the selection of a second shortcut which is to be activated the one selected previously (as above).
- **Shortcut option 2** - as per "Shortcut option" but applies to "Shortcut 2".
- **Feedback** - identifies the type of command feedback.
  - **SMS** - feedback will be provided by an SMS text to the telephone number of the caller (command dispatcher).
    - Positive outcome: <SMS Text>: "done"
    - Negative outcome: <SMS Text>: "failed"<Cause>
    - <Cause> is the explanation of failure to carry out the command.
      - "Invalid code"
      - "Invalid terminal"
      - "Terminal already in the requested status"
      - "Code not enabled"
      - "Zone not ready"
      - "Unbypassable zone"
  - **Ring** - feedback is provided on the telephone of the caller (command dispatcher). Positive outcome is indicated by a "ring"; negative outcome is indicated by no "ring".

---

Both SMS and Ring feedback occur only when the caller's telephone number is available (caller number not hidden).

---

## Note

- **Buzzer** - feedback is provided by an audible signal on the Nexus buzzer. Positive outcome is indicated by a three short audible signals; negative outcome is indicated by five long audible signals.

Users who wish to activate a command via SMS text must enter the command details as follows:

<xxxxxx> <SMS Text>

where:

- <xxxxxx> stands for the user-access PIN
- a blank space must be keyed in after PIN entry
- <SMS Text> which is the command identifier, as previously described

You wish the control panel to activate "Scenario 3", switch On the perimeter lights and confirm the operation via SMS text. For an operation of this type, proceed as follows:

## COMMAND USING SMS TEXT

## EXAMPLE

1. "SMS Text" - choose the desired description, for example "Night mode"
2. "Shortcut" - select the "Arm/Disarm" shortcut
3. "Shortcut option": "Scenario 3"
4. "Shortcut 2" - select the "Activate outputs" shortcut
5. "Shortcut option 2" - the output associated with the perimeter lights
6. "Confirm" - SMS

When a user keys in the following SMS text on a mobile (cellular) phone:

123456 Night mode

where "123456" stands for the User's access PIN and this message is sent to the number of the SIM card of the Nexus, the control panel will carry out the requested operations and will send confirmation to the mobile phone of the caller who dispatched the command.

The installer by modify the five predefined default commands:

## DEFAULT COMMANDS

- **"CREDIT"** for balance enquiries relating to the SIM card of the Nexus - the user will receive an SMS text indicating the remaining credit.
- **"STATUS"** for status enquiries relating to the Nexus - the user will receive an SMS text indicating the:
  - device name and firmware revision
  - GSM network provider
  - GSM signal reception level
  - device tamper status
  - BUS status
  - Balance (remaining credit)

- "EXC" (or "ESC"), to inhibit the control panel zones
- "INC", to activate the control panel zones

For the last two commands, the message text must be:

<xxxxxx> EXC <zone description>

where:

- <xxxxxx> is the PIN of a control-panel user coded, followed by a blank space
- "EXC" (or "ESC" or "INC") is the command to be implemented on the zone, followed by a space
- <zone description> is the name zone to be inhibited or activated

## Caller ID commands

## 6-26-2

The "Programming - Caller ID commands" section will allow you to programme up to 200 telephone numbers and the commands which will be implemented when each telephone number is recognized by the control panel. If a voice call is received from a telephone number, the command you select from those programmed in the "SMS Commands" section will be carried out.

- **Telephone number** - this is the telephone number of the caller (system user) who dispatches the command to the Nexus.
- **Code** - this field associates the user code with the telephone number. The code determines which partitions the user can operate on.
- **Actions** - this is the identifier number of the command, selected from the 30 commands programmed in the "Programming - SMS Commands" section.
- **Refuse call**
  - Enabled - when the telephone number calls, the Nexus will not answer the call but will carry out the command associated with the telephone number concerned.
  - Disabled - when the telephone number calls, the SmartLiving will answer the call and will allow it to proceed in such a way that the SmartLiving control panel can activate (if so programmed) the dialer after the programmed number of rings.
- **Receive diverted SMS** - option which, when activated, enables the selected number to receive SMS messages from the Nexus dialer which do not comply with the command-activation format.

## PANEL OPTIONS

---

A SMS "command" text message cannot be diverted.

---

## Note

## General parameters

## 6-26-3

The "Programming - General parameters" section will allow you to programme some of functions relating to management of the Nexus device.

- **Credit balance enquiry** - this identifies the method used by the Nexus to make balance enquiries to the GSM provider (regarding its own SIM).
  - **Automatic** - the Nexus will make balance enquiries to the GSM provider (regarding its own SIM) without need of programming.
  - **Manual - SMS** - balance enquiries will be made via an SMS text sent by the Nexus to the GSM provider.
  - **Manual - Call** - balance enquiries will be made via a call which will be diverted by the Nexus to the GSM provider.
  - **Manual - Network Command** - balance enquiries will be made via a special command made available by the GSM provider.
    - **Balance enquiry number** - this is the telephone number or Network command (made available by the GSM provider) for balance enquiries. This field must be programmed regardless of the type of manual mode selected (SMS, Call or Network command).
    - **Balance enquiry message** - this is the text message that will be sent to the previously mentioned number. This field must be programmed only when Manual - SMS mode is selected.
    - **Balance enquiry answer number** - this is the telephone number (made available by the GSM provider) balance information will come from. This field must be programmed regardless of the selected manual mode (SMS, call or Network command).
    - **Balance enquiry answer message** - part of the SMS answer message used to filter the information. You must type in the text which precedes the numeric value of the balance. For example, if the message sent by the GSM provider reads - "Dear customer, your remaining credit is: €15", you must type in "your remaining credit is: ".

- **Low credit threshold** - remaining credit limit, expressed in local currency. If credit drops below this limit, the Nexus dialer will signal "Low credit".
- **Credit enquiry interval** - interval, expressed in hours, which must pass between one automatic balance-enquiry and another.

If the GSM provider in question is non standard, or has modified the standard credit-notification process, you must use the manual credit-enquiry method.

- **Input volume** - this option allows you to adjust the volume of the input signal to the Nexus and thus the volume of the incoming signal to the control panel.
- **Output volume** - this option allows you to adjust the volume of the output signal from the Nexus to recipient telephone devices.
- **Volume adjust** - this option allows to balance the ratio between input and output volumes.
- **Disable tamper** - this option, if enabled, deactivates tamper signalling from the Nexus dialer.
- **Delay for Emergency signal (sec)** - interval, expressed in seconds, which the Nexus dialer allows to pass before automatically generating the signals programmed for the "Nexus loss" event.

## Note

### Text for SMS messages

### 6-26-4

The "Parameters settings - Customizable SMS Messages" section will allow you to create up to 50 SMS text messages of 80 alphanumeric characters each. These messages can be associated with the events by means of the "SMS message number/index" option described in paragraph 6-9 *Events*.



# Chapter 7

## ERRORS AND FAULTS

### Faults detected by the control panel

### 7-1

The following table shows the system faults which are signaled on the yellow LED on the keypad  :

FAULT	Message on the User menu, "View/Faults"	Probable cause	Note
<b>Zone fuse blown</b>	Zone fuse fault	Excessive current draw on the "+AUX" terminals of the control panel	
<b>BUS fuse blown</b>	IBUS fuse fault	Excessive current draw on the "+" terminal of the control panel	
<b>Backup battery inefficient or not connected</b>	Low battery	The backup battery of the control panel is almost empty or disconnected.	
<b>Primary power-source loss</b>	Mai ns fail ure	The primary power source voltage (230 Vac) has failed or has been disconnected	
<b>The PSTN landline is unavailable</b>	Tel . line down	Trouble on the PSTN landline	
<b>Interference</b>	Jammi ng	Wireless transmission is poor	
<b>Wireless detector battery low</b>	Low battery WLS	The battery of at least one wireless detector is running out	To view "LowBatt. WLS" and "LostWLSzone" events, access the "View/Faults" section of the User menu, then press 
<b>Wireless detector not operative</b>	WLS zone loss	At least one wireless detector is not operating	to view the list of devices involved in the fault event.
<b>Nexus GSM dialer faults</b>	GSM fault / Low signal	The GSM network signal is insufficient	Press  on "Nexus Fault" to access the list of current faults.
	GSM fault / GSM module fault	The GSM module of the Nexus dialer is not operating properly. Call your installer company.	
	GSM fault / SIM commun. fault	The SIM card does not respond or is not present. The SIM card PIN is not disabled.	
	Nexus Fault / Low Credit	The credit left on the SIM card is below the minimum credit threshold.	
	GSM fault / Provi der mi ssi ng	The GSM network provider of the SIM in use is unavailable.	
<b>Device loss or tamper in progress</b>	LossTamp. ongoi ng	One of the following events has occurred: <ul style="list-style-type: none"> <li>• Panel opened</li> <li>• Dislodged panel</li> <li>• Expansion tamper</li> <li>• Keypad tamper</li> <li>• Reader tamper</li> <li>• Sound.flash.Tamp</li> <li>• Expansion loss</li> <li>• Keypad loss</li> <li>• Reader loss</li> <li>• Sound.flash.Loss</li> </ul>	

<b>Faults on IVY-BUS sounderflasher</b>	Sounder faults / Horn fault	A defect/damage has been detected on the horn/sounder.	Press <b>OK</b> on "Sounder faults" to access the list of devices which have at least one fault present.  Press <b>OK</b> on the selected sounderflasher to access the list of current faults on the device concerned.
	Sounderflasher faults / LowBatt. Soundfl.	A low-voltage value has been detected on the sounderflasher battery. If the voltage drops below 10V, the device will inhibit the sounder and activate only the flasher (in the event of an alarm). If the voltage drops below 8V, the device will inhibit both the sounder and the flasher.	
	Sounderflasher Faults / Battery resist.	An excessive internal resistance has been detected on the sounderflasher battery. This type of deep fault indicates corrosion inside the battery, therefore, the battery must be replaced.	
<b>Violation of zones with faults</b>	Faults on zones	Violation has occurred on one or more zones with the "Fault zone" option enabled.	Press <b>OK</b> to access the list of zones involved.

## Communication BUS (I-BUS)

## 7-2

The control panel monitors the I-BUS continuously.

If no signals (control panel and peripheral signals) are detected on the I-BUS for over 40 seconds, the keypad displays will show the warning opposite. The display will show the:

1. Keypad model
2. Keypad firmware version
3. Error type
4. Keypad address and built-in reader address (Joy/MAX only)

First check that cable "D" of the I-BUS is connected properly. Then check the proper operating capacity of the I-BUS and the general integrity of the entire system.

If the message opposite appears on the keypad display, it means that I-BUS is operating properly but cannot communicate with the keypad in question.

Therefore, the keypad is not present in the system configuration.

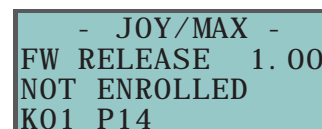
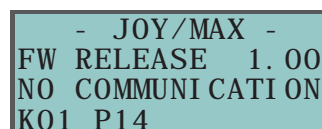

One of the two messages shown in the figures may also appear during the control panel firmware updates.

**Note**

## LED activity

## 7-3

The blue and yellow LEDs on the control panel motherboard (refer to *Table 4: Control panels - description of parts, X*) may help in providing information regarding the proper operating capacity of the control panel firmware and I-BUS, as follows.

### Blue LED

If the control panel is operating properly, the blue LED on the motherboard will blink rapidly. However, at the end of a programming session via keypad or PC, or during restoral of default settings or re-programming operations, the LED may be either On solid or Off. It will blink rapidly once the operation is completed.

If the LED is On or Off permanently for no apparent reason (see above), it means that all the system functions are blocked.

Shut the system down and contact your dealer immediately.

### Yellow LED

If the control panel is operating properly, the yellow LED on the motherboard should flicker. However, at the end of a programming session via keypad or PC, or during restoral of default settings or re-programming operations, the LED may be either On solid or Off. It will blink rapidly once the operation is completed.

If the yellow LED is On or Off permanently, it means that there is trouble on the I-BUS.

If the LED is On or Off permanently for no apparent reason (see above), it means that the I-BUS is blocked. This condition is confirmed by the loss of communication with the keypads, readers and expansions.

Check the integrity of the I-BUS line.

## Ring Sensitivity

## 7-4

The various configurations of modern telephone lines and the multiplicity of signals that transit along them, require major attention in the design of phone-line interfaces. The optimized phone-line interface on-board SmartLiving control panels has been especially designed to satisfy present day requirements. In addition to the traditional telephone plug for land line (PSTN) connections, there are usually boards for ISDN or ADSL connections.

If there are ADSL filters on the line, it will be necessary to connect the control panel downstream of the filters, to the line dedicated to telephone equipment (this line is clearly indicated on the filters).

Following are two "trouble" conditions which may be caused by ISDN or ADSL connections, etc. , and the "actions" you must take if you encounter such problems.

- **Problem** - The control panel is enabled for "Answerphone" and "Teleservice" functions but fails to pick up incoming calls after the programmed number of rings or picks up after more rings than programmed. **Answer** - Increase the value of the "Ring Sensitivity" parameter to a suitable level.
- **Problem** - The control panel is enabled for "Answerphone" and "Teleservice" functions but picks up during "through" calls (calls that should not involve the control panel). **Answer** - Decrease the value of the "Ring Sensitivity" parameter to a suitable level.



# Appendix A

## TECHNICAL TERMINOLOGY AND GLOSSARY

Violation of a zone with this attribute will generate an instant alarm even when the partitions it belongs to are disabled. The system will generate the respective alarms which will be shown on the keypad.

These zones usually monitor conditions that are not directly connected to intrusion control. For example, Water tank overflow and flooding detectors are usually configured as 24H zones.

If you are installing a fire detector, please remember that the inputs of SmartLiving control panels are not compliant with EN 50131-1 and EN 50131-3.

These are 4, 5 or 6 digit PINs which allow the building occupants (users) to access the system. Each code can be programmed to control specific functions only, and to operate the system to suit the requirements of the Main user.

Code types

- **Installer code:** used by the installer company technician
- **User code:** assigned to the building occupants

Detection of non-authorized entry into the protected building. More specifically, activation of alarm signaling devices (detectors).

A parameter generally associated with zones. This value determines the number of alarm events a zone can generate before the partitions it belongs to disarm. This value (number of alarm events) resets to zero when the zone partitions re-arm or reset.

If a zone is allowed to generate an unlimited number of alarm events, it is classified as a "repetitive" zone.

In the event of:

- Zone Alarm
- terminal tamper
- open panel or dislodged panel
- peripheral tamper (keypads, expansions, readers)
- peripheral loss (keypads, expansions, readers)
- false key

The red LEDs on the system keypads and readers go On each time one of the previously-mentioned events occur. This visual warning signal is held even after the event ends (alarm memory), in order to warn you that an event occurred during your absence. This visual warning signal will be held until you clear the event memory (refer to Delete Memory).

This is a private company that monitors premises protected by intrusion control systems equipped with Digital or Voice dialers (refer to Digital dialer and Voice dialer).

Alarm Receiving Centres receive alarm reports from monitored systems and take all the necessary actions to protect the occupants of the protected premises.

The "Answerphone" function, if enabled by the user, allows the control panel to answer incoming calls after a pre-set number of rings. The control panel will pick-up and play the recorded answer message.

During the call, the recipient can type-in a valid PIN (enabled for over-the-phone control) and access the authorized functions.

User operations on one or more partitions. These generally indicate also the status of the partitions. Under normal circumstances, the zones of armed partitions can generate alarms. Under normal circumstances, the zones of disarmed partitions cannot generate alarms. The system generates tamper alarms even when partitions are disarmed.

You can enable/disable the Auto-arm function on each separate partition.

If the auto-arm option is enabled on a timer-controlled partition, the partition will arm/disarm in accordance with the ON/OFF settings of the timer.

A zone with this attribute will be bypassed automatically by the control panel, if the partition it belongs to arms when the zone is not in standby status.

The zone will be unbypassed automatically when it restores to standby or when the partition it belongs to is disarms.

These zones operate in the same way as 24h zones, but do not generate partition alarms or visual signals on the system reader and keypad LEDs.

Zones configured in this way can be used for automation applications.

**24 HOUR ZONE**

**ACCESS CODES**

**ALARM**

**ALARM CYCLES**

**ALARM OR TAMPER MEMORY**

**ALARM RECEIVING CENTRE (ARC)**

**ANSWERPHONE**

**ARM/DISARM**

**AUTO-ARM**

**AUTO-BYPASSABLE ZONES**

**AUTOMATION ZONE**

This is the secondary power source of the system. If primary (230 Vac) power failure occurs, the battery will take over.

SmartLiving control panels use sealed lead batteries. The battery housing determines the maximum size of the battery and therefore, its power-storage capacity. SmartLiving control panels provide housing for one battery @12V 7Ah. The control panel monitors the battery continuously and keeps it under constant charge (from Mains).

Connection of a zone to a terminal configured as an input.

It is necessary to programme the balancing of each separate zone and wire the terminal accordingly. The SmartLiving intrusion control panel provides 6 different types of balancing, as follows:

- Normally Open
- Normally Closed
- EOL
- DEOL
- Double zones (only terminals with DOUBLING configuration)
- Double zones with EOL (only for terminals with DOUBLING configuration)

DEOL and customized zones can discriminate 4 conditions:

- Short-circuit
- standby
- alarm
- tamper

If you observe the Events list, you will see that there is an alarm event for each zone and a tamper event for each terminal. This is because a terminal configured as a double zone (or double zone with EOL) must be able to discriminate between alarm and standby conditions on each single zone, whereas tamper and short-circuit conditions involve the entire terminal and not the single zone.

An output, that once activated, requires an explicit command to deactivate it.

Generally, bistable outputs are used to provide immediate signaling (in real-time) of specific events that occur on the system. For example, if the "Mains Failure" event is associated with a bistable output that is connected to a LED, the LED will signal the event immediately.

A bypassed (disabled) zone cannot generate alarms. Each zone can be bypassed/unbypassed manually by the system users, or automatically by the control panel. Automatic bypass operations can take place only when the zone is configured as "Auto-bypassable" and the conditions that regulate auto-bypass operations are in effect (refer to Zone Attributes – Auto-bypassable).

Zone deactivation is useful when detectors are not working properly and you wish to avoid false alarms. Under normal circumstances, bypassed (disabled) zones can still generate tamper events. If you do not wish this to occur you must set the "Bypass Tamper" option on the control panel.

A list of outgoing event-associated calls the control panel must send to programmed contact numbers.

Enabled users can clear the call queue manually.

A zone with this attribute will generate "Chime on partition" events, if violated when the partitions it belongs to are disarmed.

Keypads which have partitions in common with the chime zone will emit an audible signal when the "Chime on partition" event occurs. If all the partitions the zone belongs to are armed, the zone will operate as programmed. This function is widely used in commercial buildings (shops, etc.), and is generally associated with the zone that monitors the entrance to the premises in order to signal the arrival of customers.

Activation of a zone with this configuration generates the command it is assigned to.

SmartLiving control panels manage the following commands:

- **Disarm zone:** if activated, it will disarm all the partitions it belongs to. Zones configured in this way can be used to disarm partitions by means of a keyswitch.
- **Arm zone:** if activated, it will arm all the partitions it belongs to. For example, keyswitches are usually configured as command zones.
- **OnArm/OffDisarm zone:** if activated, it will generate an arm-partitions command and, the instant it restores to standby, a disarm-partitions command. The command will affect only the partitions the zone belongs to. Zones configured in this way can be used to arm/disarm partitions by means of a keyswitch.
- **Switch zone:** if activated when all the partitions it belongs to are disarmed, it will arm all the partitions. If activated when even one of the partitions it belongs to is armed, it will disarm all of its partitions. The command will affect only the partitions the zone belongs to. Zones configured in this way can be used to arm/disarm partitions by means of a keyswitch.
- **Patrol zone:** if activated, it will have a patrol function in all the partitions it belongs to.

A group of operating parameters set at the factory by the manufacturer. The purpose of these settings is to reduce the work of the installer during the installation phase.

The installer can restore the system to "Default Settings" if necessary.

Violation of a zone with this configuration will not generate an alarm but will trigger the associated Timer (Entry time). If the user does not disarm the partition/s within the set "Entry time", the system will generate an alarm.

For example, the zone that monitors the main door of a building is usually configured as a Delayed Entry Zone, in order to give building occupants time to enter the building and disarm the partition without generating an alarm.

## BACKUP BATTERY

## BALANCING

## BISTABLE OUTPUT

## BYPASS - ZONE DEACTIVATION

## CALL QUEUE

## CHIME ZONE

## COMMAND ZONE

## DEFAULT SETTINGS

## DELAYED ENTRY ZONE

Violation of a zone with this configuration will not generate an alarm but will trigger the associated Timer (refer to Exit time). For example, the zone that monitors the main door of a residence or building is usually configured as a delayed exit zone, in order to give occupants time to leave the partition after an arming operation. If the user does not leave the zone within the set "Exit time", the system will generate an alarm.

**DELAYED EXIT ZONE**

This is an explicit user-command which ends signaling on the red keypad/reader LEDs of the following events:

- Zone Alarm
- terminal tamper
- open panel or dislodged panel
- peripheral tamper (keypads, expansions, readers)
- peripheral loss (keypads, expansions, readers)
- false key

**DELETE ALARM/  
TAMPER MEMORY**

If you delete the alarm/tamper memory, the visual signals on the red reader/keypad LEDs will clear.

This device allows the control panel to send report calls to Alarm Receiving centres (ARC). SmartLiving control panels provide a built-in digital dialer which supports all the most widely used protocols.

**DIGITAL DIALER**

An electrical input point used for the management/supervision of signals coming from 2 intrusion detection devices.

**DOUBLE ZONE**

The terminal the zone is connected to must be configured as a "double input zone". Terminals with this configuration allow the system to distinguish between two distinct alarms coming from the two different zones it is connected to.

The time (expressed in minutes or seconds) that the system allows the user to disarm the partition after zone violation. If the system is not disarmed within the set time it will generate an alarm.

**ENTRY TIME  
(OR ENTRY DELAY)**

Each partition can be programmed with its own Entry time.

**EVENT**

A status or operative mode recognized by the system.

For example: detector alarm, mains failure, user-code recognition, etc.

Each event (e.g. mains failure) can be associated with an activation event (when the event occurs) and a restoral event (when the event ends).

Each event can be programmed to generate the following actions:

- activation of one or more outputs
- transmission of one or more e-mails
- send one or more SMS messages
- activation of one or more voice calls
- activation of one or more digital calls

For example, it is possible to activate output 3 when the event starts and to activate output 5 when it restores.

**EVENTS LOG  
(OR EVENTS  
MEMORY)**

This is the non-volatile portion of the memory the panels saves events to. The events are saved in chronological order with the following details:

- event description - with details regarding new events and restorals
- information regarding the user or the cause of event
- event location
- event date and time

The events log can be viewed by the system users and the installer.

Partition events (zone alarms, partition alarms, arm/disarm operations, recognized codes and keys, etc.) can be viewed by users with at least one partition in common with the event element.

For example, if a user arms several partitions from a keypad, the events log will show:

- description of the event - "Arm request"
- description of the code and partitions involved
- description (label) of the keypad involved
- date and time of the request

**EXIT TIME  
(OR EXIT DELAY)**

A short period (expressed in minutes or seconds) during which the user must disarm the partition after violation (for example, after opening the front door) otherwise the system will generate an alarm.

Each partition can be programmed with its own Exit time.

**EXPANSION BOARDS  
(FLEX5)**

These boards can be used to increase the number of terminals (zones or outputs) and/or the size of the system (in order to extend it over a larger area). Expansion boards can be connected to the system via the I-BUS.

The Flex5 expansion has:

- 5 fully-programmable terminals
- a Buzzer (for audible signals)
- 1 analogue output

**FAULT**

A condition which indicates that a system component is not working properly.

Some faults can jeopardize the performance of the entire system. Mains failure (230V a.c.), telephone line-down and low battery are typical faults.

**GENERIC ZONE**

This type of zone usually comprises a motion detector which senses for the presence of movement in the protected partition. For example, PIRs, Double technology detectors, magnetic contacts on doors and windows.

A device which allows the control panel to make telephone calls over the GSM network and also allows users to interact with the control panel over-the-phone or by means of SMS text messages.

The Nexus dialer is a peripheral device which is completely SmartLiving-system-integrated and is managed through the control panel BUS.

INIM's SmartLink is a similar device which is also compatible with control panels manufactured by other makers. This device is capable of providing the control panel with a telephone line even in the event of telephone line tamper (line cutting). This function increases the level of security considerably.

Activation of a zone with this configuration generates an immediate alarm even when the partition it belongs to is disarmed. However, audible and/or visual signaling devices will not be activated (silent alarm), therefore, even calls generated by the alarm will not be revealed audibly or visually on the keypad display and LEDs.

Under normal circumstances zones with this attribute are activated manually (using hidden buttons or similar devices) in situations of duress (armed robbery, etc.).

This is the two-way communication line (4 wires only) which connects the peripheral devices (keypads, readers, expansions, etc.) to the control panel.

The 4 easily identifiable wires, on the control panel motherboard and on the expansions, are:

- "+" power 12 Volt
- "D" data
- "S" data
- "-" Ground

A terminal configured as a Controlled Output (I/O, input-output) is capable of reading the status of the output.

This configuration can be used for creating automations, for example the condition of an alarm condition on "AND" zones:

- the single alarm events of two zones activate respectively an output terminal and an I/O terminal
- both the outputs are monostable, for example at 30 seconds
- the terminals are shorted

The input section of I/O terminals triggers the alarm actions (calls and sounderflashers), only when the two zones are both violated (AND) within the monostable time of the outputs.

The Installer code is identified by a 4, 5 or 6 digit PIN. This PIN allows the installer to access the system Programming Menu either from a keypad or via the respective software programme, on condition that all the system partitions are disarmed.

List of system functions and respective parameters accessed via keypad.

This menu allows the installer to program, check and change nearly all of the system parameters. The Installer Menu can be accessed from any keypad (after entry of a valid PIN) or via computer using the SmartLeague software programme, on condition that all the system partitions are disarmed.

Violation of a zone with this attribute will generate an immediate alarm (no delay).

A zone that monitors the inside of the protected building.

For example, the interior zones of an office building are the zones that monitor offices and entrance points.

If a partition that a zone belongs to is armed in Stay mode, it will be unable to generate alarms.

A control device (card or keyfob) which allows the authorized user to access the system.

The key must be held in the vicinity of the reader in such a way to allow the system to read it and permit access to authorized operations.

Each key is programmed with:

- A random code selected from over 4 billion possible combinations.
- A label (usually the name of the user).
- The partitions it controls (arms, disarms, etc.).
- A group of pre-set parameters which allow the key user to operate the system in accordance with the authorized access level (for example, a key can be programmed to arm or disarm the system only at certain times of the day).

This device allows users to access and control the system. Keypads can be connected to the system via the I-BUS.

The keypad is equipped with:

- LCD graphic display
- 2 terminals
- alphanumeric keys for code and data entry
- LEDs for visual signals
- a buzzer (for audible signals)
- microphone and speaker (Joy/MAX only)
- built-in reader (Joy/MAX only)
- temperature sensor (Joy/MAX only)

The keypad allows users to access and control the partitions which are common to both the code and keypad in use. The user can arm/disarm partitions, view the status of the zones, stop visual and audible signaling devices.

A generic magnetic-contact is a detector/sensor based on an magnet which, when placed near the sensor, provokes the mechanical closure of an electrical contact.

The Air2-MC100 wireless device comprises a magnetic-contact with 2 terminals (T1 and T2) which can be configured as either inputs or outputs. The magnetic-contact is equipped with a horizontal magnetic sensor and a vertical magnetic sensor, positioned along the sides of the device.

## **GSM DIALER**

## **HOLD-UP ZONE (OR PANIC ZONE OR SILENT ZONE)**

## **I-BUS**

## **I/O TERMINAL**

## **INSTALLER CODE**

## **INSTALLER MENU**

## **INSTANT ZONE**

## **INTERIOR ZONE**

## **KEY**

## **KEYPAD (JOY)**

## **MAGNETIC CONTACT (AIR2-MC100)**

If you wish to carry out maintenance work on the control without generating false alarms (tamper and intrusion), you must put the control panel in "Maintenance" mode. The control panel must also be in "Maintenance" mode during the keypad and reader addressing process. The other functions of the control panel are still available (arm/disarm operations, events, calls, etc.).

An output, that once activated, does not require an explicit command to deactivate it. This output must be programmed with a timeout (Monostable time expressed in seconds or minutes). Once activated, this output will remain active until the pre-set Monostable time expires.

Generally, monostable outputs are used to provide continuous signaling of the events they are associated with. For example, if the "Alarm Partition 1" event is associated with a monostable output with a 2 minute timeout, the output (sounder) will signal the event for 2 minutes then will deactivate automatically.

An advanced wireless-technology system in which the control panel and its devices are equipped with a transceiver module. If a detector senses an alarm condition, it will generate a number of event transmissions which under the right circumstances should reach the control panel.

An electrical output point connected to a signaling or control device activated/deactivated by the control panel in response to programmed events.

The terminal the device is connected to must be configured as an "output".

Outputs are usually connected to audible or visual signaling devices but can be used for other purposes such as: switching on lights or opening doors/gates.

A group of zones.

A partition identifies a group of zones that belong to a spatial or logical portion of the protected premises. For example, a partition may comprise all the zones that protect the downstairs partition of a house (spatial partition), or all the entrances of an office building (logical partition).

This refers to the status of a partition as requested by the user.

The user can carry out the following operations.

- **Disarm** - this operation disables the partition completely. In this way, none of the zones belonging to the partition can generate alarms.
- **Away mode** - this operation enables the interior and perimeter zones of the partition. In this way, all of the zones of the partition can generate alarms.
- **Stay mode** - this operation enables only the perimeter zones of the partition. In this way, only the perimeter zones of the partition can generate alarms.
- **Instant mode** - this operation enables the partition perimeter zones only and annuls delays. In this way, violation of the perimeter zones of the partition will generate instant alarms.
- **Hold** - this operation forces the partition to hold its current status.

A periodic inspection of the protected premises carried out by authorized security staff.

Patrol staff can disarm each partition for the pre-set time only (programmable separately for each partition). The partitions concerned will rearm-as-before automatically when the pre-set time expires. Persons involved in periodic security inspections require codes with the "Patrol" attribute.

If the system receives a partition disarm command (generated by a code or key) while the patrol time is running, the "Patrol" function will be interrupted immediately. In this case, when the patrol time expires the partition will not be re-armed automatically and therefore, will be disarmed.

A zone that monitors the entrance points of the protected building.

Perimeter zones are usually direct entrance points such as doors and windows. For example, the front door of an apartment and windows that allow access from outside.

Devices connected to the control panel via the I-BUS.

SmartLiving control panels manage the following peripherals:

- JOY series Keypads
- Proximity Readers (nBy)
- Expansions (Flex5)
- Transceiver (Air2-BS100)
- Sounderflashers (Ivy)
- Isolators (IB100)
- GSM dialer (Nexus)

The period (expressed in minutes) before an automatic arming operation.

For example, if a partition is set to arm automatically at 10:30 with a Pre-arm time of 5 minutes, all the partition keypads and readers will initiate an audible countdown at 10:25 in order to warn users of the forthcoming arming operation.

Each partition can be programmed with its own Pre-arm time.

The installation site.

Identifies the building or part protected by the intrusion control system, generally, a house or office.

Under normal circumstances, the mains power supply (230Vac) 50 Hz (110V a.c. 60Hz in some countries).

Usually connected to a switching power supply or transformer (depending on the model) that provides the stabilized voltage to the system and the charge source to the batteries.

## MAINTENANCE

## MONOSTABLE OUTPUT

## ONE-WAY WIRELESS SYSTEM

## OUTPUT

## PARTITION

## PARTITION ARM/ DISARM OPERATIONS

## PATROL

## PERIMETER ZONE

## PERIPHERALS

## PRE-ARM TIME

## PREMISES

## PRIMARY POWER SOURCE

Pulse events are events which are a combination of other control panel events based on logical operations, counters and temporizers.

For example, when it is necessary for more than one PIR detector to signal violation within a pre-set time in order to generate an alarm.

Spot events are events which restore automatically immediately after their activation. Some of the previously mentioned events are spot events.

For example, the "valid code" event activates as soon as the code is entered at the keypad, therefore, it is impossible to determine its restoration as it starts and ends instantly.

Pulse events (Spot events) can be programmed to activate:

- an output and calls when the event occurs
- an output when the event restores (only if the output has the option "ON afterRestoral" activated)

Under normal circumstances, spot events are assigned to monostable outputs (Refer to Monostable Outputs).

This device allows users to access and control the system. The system readers are connected to the control panel via the I-BUS.

Readers are equipped with:

- LEDs for visual signals
- a buzzer for audible signals (nBy/S only)
- key reader (TAG)

The key (TAG) allows the user to activate shortcuts (refer to Shortcuts) and arm/disarm the partitions which are common to both the key (TAG) and reader in use. The key (TAG) must be held in the vicinity of the reader in such a way to allow the system to read it and permit access to authorized operations. Although readers provide a more limited access to the system, they are the easiest way of carrying out day-to-day operations (arm, disarm, etc.).

This type of zone comprises a sensor that detects any movement of the protected rollerblind.

Violation of a zone with this configuration will not generate an alarm during the pre-set Entry time (refer to Entry time).

For example, the zones that monitor the way to a command device (Keypad/Reader) are usually configured as Path Zones, in order to give building occupants time to enter the building, reach the command device (Keypad/Reader) and disarm the partition without generating an alarm.

Violation of a zone with this configuration will generate an instant alarm if the Entry time (Entry delay) has been revoked (as per Stay Mode).

A pre-set arming configuration which applies various operating modes to the system partitions.

Following is an example of a pre-set scenario:

- Partition 1Disarm
- Partition 2Away arm
- Partition 3Stay arm
- Partition 4Hold
- Partition 5Disarm

SmartLiving control panels can be programmed (by the installer) with as many as 30 scenarios in accordance with user requirements.

The "Arm/disarm" shortcut must always be associated with one of the 30 available scenarios. When the system applies the selected scenario, the partitions will arm accordingly.

This type of zone usually comprises a shock detector (e.g Glassbreak detector) which senses for shock waves (vibration caused by hard blows).

The shortcuts allow quick access to User Menu options which normally require several step-by-step operations.

For example, to activate/deactivate an output manually, you must:

1. Type in a user code.
2. Access the User Menu.
3. Select the option (activate outputs).
4. Select the required element (output).
5. Activate/Deactivate the selected element (output).

Instead, the "Activate outputs" and "Deactiv. outputs" shortcuts allow you to activate/deactivate an output by simply pressing a single key or, if required for security reasons, after entering a user code.

The shortcuts can be assigned to:

- keypads
- codes (entered at the keypad or via remote telephone)
- readers
- keys

Some shortcuts (for example, "Activate Outputs") require details before the system can implement them. These details (parameter, value, etc.) depend on the source of the shortcut command (keypad, code, reader, keys).

Refer to the details in the *Appendix B* a pagina 89 shortcuts list.

Shortcuts 0 to 8 implement their associated actions instantly whereas, shortcuts 10 to 35, which can be activated from keypads only, access the menu section specified by the user.

An output that is monitored and therefore allows verification of its improper operating capacity (unsuccessful activation/deactivation).

## PROGRAMMABLE EVENT

## PULSE EVENTS

## READER (NBY)

## ROLLERBLIND ZONE

## ROUTE ZONE

## SCENARIO

## SHOCK ZONE

## SHORTCUTS

## SUPERVISED OUTPUT

The "supervision time" is the interval during which the wireless-system devices (in general wireless detectors in permanent placements) must signal to the control panel that they are operating in the network. If a wireless device fails to signal before the "supervision time" expires, it will be classified as "Lost" and the control panel will trigger a "peripheral-loss" fault event.

Detection of a serious condition that jeopardizes the operating capacity of the device concerned and thus puts the system at risk.

Tamper conditions are detected by tamper switches connected to the system zones, keypads, readers, expansions and control panel. Generally, these events are triggered by system violation such as unauthorized opening of a keypad cover.

These are calls sent to programmed contact numbers when specific events start and end (restoral).

This is a service provided by the installer company. The installer company requires the user's collaboration and authorization before opening a teleservice session and working on the system via telephone line.

A screw terminal for the connection of zones (detection devices) and/or outputs (command/signaling devices).

The terminals (with some exceptions) of the control panel, keypads and expansion boards can be configured as:

- Input zone
- Double zone (ZONE DOUBLING)
- Output
- Supervised output
- Unused terminal

A zone with this attribute cannot generate alarms (activate audible and visual signaling devices). However, any alarm events that occur will be saved to the events memory.

The installer usually assigns the "test" attribute when the system is undergoing tests, in order to avoid false alarms. In this way, the installer can see if a zone is operating properly by simply referring to the events log.

A logical entity for automatic time-management of programmed peripherals or elements.

SmartLiving control panels provide 10 timers.

Each timer can be programmed to manage:

- An activation time (ON Time) and a deactivation time (OFF Time) on preset days of the week and specific dates.
- 5 timer-slot exceptions. Each "exception" refers to a specific interval of one or more days, which can be programmed with an ON and OFF Time.

The timers can be used for different purposes:

- If a timer is associated with a partition, the system will arm and disarm the partition automatically in accordance with the On/Off settings of the timer.
- If a timer is associated with a code, the latter will be allowed to access the system only when the timer is On.
- If a timer is associated with a key, the latter will be allowed to access the system only when the timer is On.
- If the "Timer xxx" event is assigned to an output, the latter will activate/deactivate the connected device in accordance with the On/Off settings of the timer.

No matter how they are employed, the timers must always be enabled by the user.

Transceiver-equipped devices

In two-way wireless systems, all the devices are equipped with transceivers. In one-way wireless systems, the main unit is equipped with a receiver module whereas the peripheral devices are equipped with transmitters.

A wireless-technology system in which the control panel and its devices are equipped with a transmitter module and a receiver module.

These systems are more reliable than one-way wireless systems as each device transmission is validated by a reverse transmission.

A zone with this attribute cannot be bypassed, manually (by the user) or automatically (by the control panel).

This attribute is usually assigned to high-security zones.

If a terminal is configured as an "unused" terminal, it will not be included in the terminal configuration (total sum of control panel terminals).

This ensures that any "Unused" terminals on the expansion boards and keypads are still available for use.

Each code is programmed with:

- A 4, 5 or 6 digit PIN which allows access the system.
- A label which identifies the user (usually the user's name).
- The group of partitions it controls (arms, disarms, etc.).
- A group of pre-set parameters which allow the operator to work on the system in accordance with its authorized access level (for example, a code can be enabled to consult the events log but not to change the date and time).

List of functions available to the user after valid code entry at a keypad.

This is a delayed entry and exit zone and does not generate alarms when violation occurs during the running entry/exit time, however, the violation will be signaled on the keypad.

**SUPERVISION****TAMPER****TELEPHONE ACTIONS****TELESERVICE****TERMINAL****TEST ZONE****TIMER****TRANSCEIVER****TWO-WAY WIRELESS SYSTEM****UNBYPASSABLE ZONE****UNUSED TERMINAL****USER CODE****USER MENU****VIEWABLE DELAYED ZONE**

This device allows the control panel to send voice calls to programmed contact numbers. In SmartLiving control panels the voice dialer function is provided by the SmartLogos30M board (accessory item).

**VOICE DIALER**

If the system is equipped with a SmartLogos30M voice board, each JOY/MAX keypad, in the system configuration will allow users to record memos. Memos can be recorded, played and deleted as required.

**VOICE MEMO**

An intrusion control system whose devices (detectors, keypads, keyfobs) communicate with the control panel over radio waves.

**WIRELESS**

Usually, only the control panel of wireless-systems is mains powered (220Va.c.) while, the wireless devices are battery powered. The battery life is of utmost importance in the design layout and operational capacity of these systems.

An electrical input point used for the management/supervision of signals coming from an intrusion detection device. The terminal the zone is connected to must be configured as an "input" zone.

**ZONE**

Zones are usually connected to a single device, however, it is possible (if the zone is duly wired and configured) to connect more than one device. If a zone is connected to more than one device it is impossible to identify the alarm-trigger device in the event of an alarm.

The conditions which generate a zone alarm, on the understanding that the zone belongs to several partitions, are as follows: the zone must detect violation and all the partitions it belongs to must be armed.

**ZONE ALARM**

Zone alarms provoke activation of audible and visual signaling devices (sounders, flashers, reader/keypad LEDs, etc.) and generate voice and digital calls. Zone alarm events automatically generate partition alarm events on all the partitions the zone belongs to.

A violated zone will not generate alarms if:

- it belongs to several partitions and one of them is disarmed
- it is inhibited
- it is in test status (the event will be saved to the events log only)
- it an "interior" zone, and one of the partitions it belongs to is armed in Stay or Instant mode



# Appendix B

## SHORTCUTS AT DEFAULT

macro num.	ICON	description	function	parameter
1		<b>Arm/Disarm</b>	Applies a pre-set scenario	Scenario
2		<b>Stop alarms</b>	Immediately deactivates the outputs relative to zone/partition alarm and tamper events and system tamper events.	
3		<b>Clear call queue</b>	Cancels the call queue and stops ongoing calls (if any).	
4		<b>Delete memory</b>	Carries out a "Stop alarms" operation and, at the same time, deletes memory of system and partition alarm and tamper events.	
5		<b>Activate outputs</b>	Activates one of the programmed outputs.	Output
6		<b>Deactiv. outputs</b>	Deactivates one of the programmed outputs.	Output
7		<b>Overtime</b>	Delays auto-arming time of partitions by 30 minutes.	
8		<b>Teleservice req.</b>	Sends a call to the Installer company number (Teleservice number).	
9		<b>Voice menu</b>	Plays a recorded voice message which announces the shortcuts assigned to the number keys.	User code
10		<b>Listen-in</b>	Allows eavesdropping over-the-phone by means of a microphone located on suitably placed keypad.	Keypad
11		<b>Intercom Call</b>	Accesses the User Menu section: Voice functions/ Intercom Call	
12		<b>Arm/disarm menu</b>	Accesses the User Menu section: Arm/Disarm	
13		<b>Alarm menu</b>	Accesses the User Menu section: Manage alarms	
14		<b>Voice func. menu</b>	Accesses the User Menu section: Voice functions	
15		<b>Activations menu</b>	Accesses the User Menu section: Activations	
16		<b>View menu</b>	Accesses the User Menu section: View	
17		<b>Arming status</b>	Provides voice information regarding the armed/disarmed status of the partitions.	
18		<b>Keypad sett. menu</b>	Accesses the User Menu section: Keypad Keypad	

macro num.	ICON	description	function
19		<b>ZoneBypass menu</b>	Accesses the User Menu section: Activations/Zones
20		<b>Voice memo</b>	Accesses the User Menu section: Voice functions
21		<b>Output control</b>	Accesses the User Menu section: Outputs ON/OFF
22		<b>Enab.answerphone</b>	Accesses the User Menu section: Activations/ Answerphone
23		<b>Enab.teleservice</b>	Accesses the User Menu section: Activations/ Teleservice
24		<b>Enable codes</b>	Accesses the User Menu section: Activations/Codes
25		<b>Enable keys</b>	Accesses the User Menu section: Activations/Keys
26		<b>Enable timers</b>	Accesses the User Menu section: Activations/Timers
27		<b>Enab. auto-arm</b>	Accesses the User Menu section: Activations/Auto-arm
28		<b>View events log</b>	Accesses the User Menu section: View/Events log
29		<b>View alarm log</b>	Accesses the User Menu section: View/Alarms log
30		<b>View faults log</b>	Accesses the User Menu section: View/Faults log
31		<b>View arm ops log</b>	Accesses the User Menu section: View/Arm/Disarm ops.
32		<b>ViewSystemStatus</b>	Accesses the User Menu section: View/System Voltage
33		<b>View zone status</b>	Accesses the User Menu section: View/Zone status
34		<b>Change PIN</b>	Accesses the User Menu section: Change PIN
35		<b>Time/Date</b>	Accesses the User Menu section: Time/Date
36		<b>View faults</b>	Accesses the User Menu section: View/Faults
37		<b>Thermostat</b>	Accesses the User Menu section: Thermostat

# Appendix C

## AVAILABLE ICONS

The following table shows the icons provided at default. The icons can be customized to suit the keypad shortcuts.

icon number	ICON	icon number	ICON	icon number	ICON
1		19		37	
2		20		38	
3		21		39	
4		22		40	
5		23		41	
6		24		42	
7		25		43	
8		26		44	
9		27		45	
10		28		46	
11		29		47	
12		30		48	
13		31		49	
14		32		50	
15		33			
16		34			
17		35			
18		36			

# Appendix D

## VOICE MESSAGES

The SmartLogos30M voice board provides 500 voice message slots, 291 of which are pre-recorded at factory. The messages are arranged in such way as to produce event-related voice calls which clearly describe the related event.

The following Table shows the message numbers and their purpose, together with the respective recording time.

Type	Number	Default message	Message duration (seconds)	
			High quality	Average quality
Available user-messages	1 - 100	∞	169 (for all 100 messages)	271 (for all 100 messages)
None available	101 - 165	∞		
Arming scenarios	166	Scenario 1	2.5	4
	167	Scenario 2	2.5	4
	168	Scenario 3	2.5	4
	169	Scenario 4	2.5	4
	170	Scenario 5	2.5	4
	171	Scenario 6	2.5	4
	172	Scenario 7	2.5	4
	173	Scenario 8	2.5	4
	174	Scenario 9	2.5	4
	175	Scenario 10	2.5	4
	176	Scenario 11	2.5	4
	177	Scenario 12	2.5	4
	178	Scenario 13	2.5	4
	179	Scenario 14	2.5	4
	180	Scenario 15	2.5	4
	181	Scenario 16	2.5	4
	182	Scenario 17	2.5	4
	183	Scenario 18	2.5	4
	184	Scenario 19	2.5	4
	185	Scenario 20	2.5	4
	186	Scenario 21	2.5	4
	187	Scenario 22	2.5	4
	188	Scenario 23	2.5	4
	189	Scenario 24	2.5	4
	190	Scenario 25	2.5	4
	191	Scenario 26	2.5	4
	192	Scenario 27	2.5	4
	193	Scenario 28	2.5	4
	194	Scenario 29	2.5	4
	195	Scenario 30	2.5	4
Shortcuts	196	Armed in Away mode	2.5	4
	197	Stop alarm	2.5	4
	198	Stop call queue	2.5	4
	199	Delete memory	2.5	4
	200	Activate output	2.5	4
	201	Deactivate output	2.5	4
	202	Overtime request	2.5	4
	203	Request maintenance	2.5	4
	204	StartVoiceNotifier	2.5	4
	205	Listen-in	2.5	4
	206	Intercom Call	2.5	4
	207	Access arm/disarm menu	2.5	4
	208	Access manage alarms menu	2.5	4
	209	Voice menu	2.5	4
	210	Activations menu	2.5	4
	211	View menu	2.5	4
	212	System status	2.5	4
	213	Keypad settings menu	2.5	4
	214	Zone activations menu	2.5	4
	215	Voice memo	2.5	4
	216	Output management menu	2.5	4
	217	Enable/Disable answerphone	2.5	4
	218	Enable teleservice	2.5	4
	219	Enable codes	2.5	4
	220	Enable keys	2.5	4
	221	Enable timers	2.5	4
	222	Enable auto-arming	2.5	4
	223	View events log	2.5	4
	224	View alarms log	2.5	4
	225	View faults log	2.5	4
	226	View arm/disarm operations	2.5	4
	227	View battery status	2.5	4
	228	View zone status	2.5	4
	229	Change PIN	2.5	4

Type	Number	Default message	Message duration (seconds)	
			High quality	Average quality
Zone Terminal	330	Zone 60	3.13	5
	331	Zone 61	3.13	5
	332	Zone 62	3.13	5
	333	Zone 63	3.13	5
	334	Zone 64	3.13	5
	335	Zone 65	3.13	5
	336	Zone 66	3.13	5
	337	Zone 67	3.13	5
	338	Zone 68	3.13	5
	339	Zone 69	3.13	5
	340	Zone 70	3.13	5
	341	Zone 71	3.13	5
	342	Zone 72	3.13	5
	343	Zone 73	3.13	5
	344	Zone 74	3.13	5
	345	Zone 75	3.13	5
	346	Zone 76	3.13	5
	347	Zone 77	3.13	5
	348	Zone 78	3.13	5
	349	Zone 79	3.13	5
	350	Zone 80	3.13	5
	351	Zone 81	3.13	5
	352	Zone 82	3.13	5
	353	Zone 83	3.13	5
	354	Zone 84	3.13	5
	355	Zone 85	3.13	5
	356	Zone 86	3.13	5
	357	Zone 87	3.13	5
	358	Zone 88	3.13	5
	359	Zone 89	3.13	5
	360	Zone 90	3.13	5
	361	Zone 91	3.13	5
	362	Zone 92	3.13	5
	363	Zone 93	3.13	5
	364	Zone 94	3.13	5
365	Zone 95	3.13	5	
366	Zone 96	3.13	5	
367	Zone 97	3.13	5	
368	Zone 98	3.13	5	
369	Zone 99	3.13	5	
370	Zone 100	3.13	5	
Partition	371	Partition 1	3.13	5
	372	Partition 2	3.13	5
	373	Partition 3	3.13	5
	374	Partition 4	3.13	5
	375	Partition 5	3.13	5
	376	Partition 6	3.13	5
	377	Partition 7	3.13	5
	378	Partition 8	3.13	5
	379	Partition 9	3.13	5
	380	Partition 10	3.13	5
	381	Partition 11	3.13	5
	382	Partition 12	3.13	5
	383	Partition 13	3.13	5
	384	Partition 14	3.13	5
	Codes	385	Partition 15	3.13
386		Code 1	2.5	4
387		Code 2	2.5	4
388		Code 3	2.5	4
389		Code 4	2.5	4
390		Code 5	2.5	4
391		Code 6	2.5	4
392		Code 7	2.5	4
393		Code 8	2.5	4
394		Code 9	2.5	4
395		Code 10	2.5	4

Type	Number	Default message	Message duration (seconds)	
			High quality	Average quality
Shortcuts	230	Date/Time settings	2.5	4
	231	Faults list	2.5	4
None available	232 - 240	''		
Generic messages	241	Restoral	1.25	2
	242	To	0.63	1
	243	Press	1.25	2
	244	Location	6.25	10
	245	Zero	2.5	4
	246	One	2.5	4
	247	Two	2.5	4
	248	Three	2.5	4
	249	Four	2.5	4
	250	Five	2.5	4
	251	Six	2.5	4
	252	Seven	2.5	4
	253	Eight	2.5	4
	254	Nine	2.5	4
Partition status	255	Away mode	3.13	5
	256	Armed in Stay mode	3.13	5
	257	Instant mode	3.13	5
	258	Disarm	3.13	5
Menu	259	To go back to previous menu press	3.13	5
Activation / Deactivation	260	To activate	1.88	3
	261	To deactivate	1.88	3
Type-in user-code PIN	262	Type-in user-code PIN followed by #	2.5	4
Outputs	263	Relay	2.5	4
	264	Output 1	2.5	4
	265	Output 2	2.5	4
None available	266 - 270	''		
Zone Terminal	271	Zone 1	3.13	5
	272	Zone 2	3.13	5
	273	Zone 3	3.13	5
	274	Zone 4	3.13	5
	275	Zone 5	3.13	5
	276	Zone 6	3.13	5
	277	Zone 7	3.13	5
	278	Zone 8	3.13	5
	279	Zone 9	3.13	5
	280	Zone 10	3.13	5
	281	Zone 11	3.13	5
	282	Zone 12	3.13	5
	283	Zone 13	3.13	5
	284	Zone 14	3.13	5
	285	Zone 15	3.13	5
	286	Zone 16	3.13	5
	287	Zone 17	3.13	5
	288	Zone 18	3.13	5
	289	Zone 19	3.13	5
	290	Zone 20	3.13	5
	291	Zone 21	3.13	5
	292	Zone 22	3.13	5
	293	Zone 23	3.13	5
	294	Zone 24	3.13	5
	295	Zone 25	3.13	5
	296	Zone 26	3.13	5
	297	Zone 27	3.13	5
	298	Zone 28	3.13	5
	299	Zone 29	3.13	5
	300	Zone 30	3.13	5
	301	Zone 31	3.13	5
	302	Zone 32	3.13	5
	303	Zone 33	3.13	5
	304	Zone 34	3.13	5
	305	Zone 35	3.13	5
	306	Zone 36	3.13	5
	307	Zone 37	3.13	5
	308	Zone 38	3.13	5
	309	Zone 39	3.13	5
	310	Zone 40	3.13	5
	311	Zone 41	3.13	5
	312	Zone 42	3.13	5
	313	Zone 43	3.13	5
	314	Zone 44	3.13	5
	315	Zone 45	3.13	5
	316	Zone 46	3.13	5
317	Zone 47	3.13	5	
318	Zone 48	3.13	5	
319	Zone 49	3.13	5	
320	Zone 50	3.13	5	
321	Zone 51	3.13	5	
322	Zone 52	3.13	5	
323	Zone 53	3.13	5	
324	Zone 54	3.13	5	
325	Zone 55	3.13	5	
326	Zone 56	3.13	5	
327	Zone 57	3.13	5	
328	Zone 58	3.13	5	
329	Zone 59	3.13	5	
330	Zone 60	3.13	5	

Type	Number	Default message	Message duration (seconds)	
			High quality	Average quality
Keys	396	Key 1	2.5	4
	397	Key 2	2.5	4
	398	Key 3	2.5	4
	399	Key 4	2.5	4
	400	Key 5	2.5	4
	401	Key 6	2.5	4
	402	Key 7	2.5	4
	403	Key 8	2.5	4
	404	Key 9	2.5	4
	405	Key 10	2.5	4
Keypads	406	Keypad 1	2.5	4
	407	Keypad 2	2.5	4
	408	Keypad 3	2.5	4
	409	Keypad 4	2.5	4
	410	Keypad 5	2.5	4
Readers	411	Reader 1	2.5	4
	412	Reader 2	2.5	4
	413	Reader 3	2.5	4
	414	Reader 4	2.5	4
	415	Reader 5	2.5	4
Function keys Emergency	416	Fire	2.5	4
	417	Ambulance	2.5	4
	418	Police	2.5	4
None available	419	''		
Event type	420	Zone alarm	2.5	4
	421	Terminal tamper	2.5	4
	422	Partition alarm	2.5	4
	423	Stay alarm	2.5	4
	424	Partition tamper	2.5	4
	425	Zone bypass	2.5	4
	426	Real time zone	2.5	4
	427	Partition not-ready-to-arm	2.5	4
	428	Away arm request	2.5	4
	429	Stay arm request	2.5	4
	430	Armed in Away mode	2.5	4
	431	Armed in Stay mode	2.5	4
	432	Reset partition	2.5	4
	433	Partition armed, leave partition	2.5	4
	434	Disarm partition	2.5	4
	435	Pre-arm alert	2.5	4
	436	Overtime request	2.5	4
	437	Welcome	2.5	4
	438	Forced arming	2.5	4
	439	Failed to arm	2.5	4
	440	Valid user-code	2.5	4
	441	Valid key	2.5	4
	442	Valid user-code at keypad	2.5	4
	443	Valid key at reader	2.5	4
	444	Valid user-code on partition	2.5	4
	445	Valid key on partition	2.5	4
	446	Failed call	2.5	4
	447	Timer activated	2.5	4
	448	Thermostat	2.5	4
	449	Scenario	2.5	4
	450	Programmable event	2.5	4
	451	Emergency	2.5	4
	452	Open-panel tamper	2.5	4
	453	Dislodged-panel tamper	2.5	4
	454	Zone fuse fault	2.5	4
	455	I-BUS fuse fault	2.5	4
	456	Battery fault	2.5	4
	457	Mains failure	2.5	4
	458	Expansion tamper	2.5	4
	459	Keypad Tamper	2.5	4
	460	Reader Tamper	2.5	4
	461	Sounder flasher tamper	2.5	4
	462	Nexus tamper	2.5	4
	463	Expansion Loss	2.5	4
	464	Keypad Loss	2.5	4
	465	Reader Loss	2.5	4
	466	Sounder flasher loss	2.5	4
	467	Nexus loss	2.5	4
468	Jamming	2.5	4	
469	Low battery wireless zone	2.5	4	
470	Wireless zone loss	2.5	4	
471	Valid Installer code	2.5	4	
472	Invalid code			
473	False key			
474	Nexus fault			
475	Telephone line down			
476	Periodic test event			
477	Hard reset			
478	Call queue full			
479	Successful call			
480	Initialize programming			
481	Ongoing call			
482	Failed to send message			
483	Output fault			
None available	484 - 485	''		
Voice memo slots	486 - 500	''	37.5 (for all 15 messages)	60 (for all 15 messages)

# Appendix E

## SCREW TERMINALS

All the terminals on the SmartLiving control panel and its peripherals (expansions and keypads) are identified by distinctive numbers transcribed in the "CCC" programming field of the "CONTACT-ID" protocol, in order to allow the precise localization of events related to zones or terminals.

In the case of double zones, the second zone will be identified by the number "500 + n." (where "n." stands for the number of the terminal).

n.	SLiving 505	SLiving 515	SLiving 1050	SLiving 10100
1	Panel T1	Panel T1	Panel T1	Panel T1
2	Panel T2	Panel T2	Panel T2	Panel T2
3	Panel T3	Panel T3	Panel T3	Panel T3
4	Panel T4	Panel T4	Panel T4	Panel T4
5	Panel T5	Panel T5	Panel T5	Panel T5
6			Panel T6	Panel T6
7			Panel T7	Panel T7
8			Panel T8	Panel T8
9			Panel T9	Panel T9
10			Panel T10	Panel T10
11	Exp. 1 T1	Exp. 1 T1	Exp. 1 T1	Exp. 1 T1
12	Exp. 1 T2	Exp. 1 T2	Exp. 1 T2	Exp. 1 T2
13	Exp. 1 T3	Exp. 1 T3	Exp. 1 T3	Exp. 1 T3
14	Exp. 1 T4	Exp. 1 T4	Exp. 1 T4	Exp. 1 T4
15	Exp. 1 T5	Exp. 1 T5	Exp. 1 T5	Exp. 1 T5
16	Exp. 2 T1	Exp. 2 T1	Exp. 2 T1	Exp. 2 T1
17	Exp. 2 T2	Exp. 2 T2	Exp. 2 T2	Exp. 2 T2
18	Exp. 2 T3	Exp. 2 T3	Exp. 2 T3	Exp. 2 T3
19	Exp. 2 T4	Exp. 2 T4	Exp. 2 T4	Exp. 2 T4
20	Exp. 2 T5	Exp. 2 T5	Exp. 2 T5	Exp. 2 T5
21	Exp. 3 T1	Exp. 3 T1	Exp. 3 T1	Exp. 3 T1
22	Exp. 3 T2	Exp. 3 T2	Exp. 3 T2	Exp. 3 T2
23	Exp. 3 T3	Exp. 3 T3	Exp. 3 T3	Exp. 3 T3
24	Exp. 3 T4	Exp. 3 T4	Exp. 3 T4	Exp. 3 T4
25	Exp. 3 T5	Exp. 3 T5	Exp. 3 T5	Exp. 3 T5
26	Exp. 4 T1	Exp. 4 T1	Exp. 4 T1	Exp. 4 T1
27	Exp. 4 T2	Exp. 4 T2	Exp. 4 T2	Exp. 4 T2
28	Exp. 4 T3	Exp. 4 T3	Exp. 4 T3	Exp. 4 T3
29	Exp. 4 T4	Exp. 4 T4	Exp. 4 T4	Exp. 4 T4
30	Exp. 4 T5	Exp. 4 T5	Exp. 4 T5	Exp. 4 T5
31	Keyp. 1 T1	Exp. 5 T1	Exp. 5 T1	Exp. 5 T1
32	Keyp. 1 T2	Exp. 5 T2	Exp. 5 T2	Exp. 5 T2
33	Keyp. 2 T1	Exp. 5 T3	Exp. 5 T3	Exp. 5 T3
34	Keyp. 2 T2	Exp. 5 T4	Exp. 5 T4	Exp. 5 T4
35	Keyp. 3 T1	Exp. 5 T5	Exp. 5 T5	Exp. 5 T5
36	Keyp. 3 T2	Exp. 6 T1	Exp. 6 T1	Exp. 6 T1
37	Keyp. 4 T1	Exp. 6 T2	Exp. 6 T2	Exp. 6 T2
38	Keyp. 4 T2	Exp. 6 T3	Exp. 6 T3	Exp. 6 T3
39	Keyp. 5 T1	Exp. 6 T4	Exp. 6 T4	Exp. 6 T4
40	Keyp. 5 T2	Exp. 6 T5	Exp. 6 T5	Exp. 6 T5
41		Exp. 7 T1	Exp. 7 T1	Exp. 7 T1
42		Exp. 7 T2	Exp. 7 T2	Exp. 7 T2
43		Exp. 7 T3	Exp. 7 T3	Exp. 7 T3
44		Exp. 7 T4	Exp. 7 T4	Exp. 7 T4
45		Exp. 7 T5	Exp. 7 T5	Exp. 7 T5
46		Exp. 8 T1	Exp. 8 T1	Exp. 8 T1
47		Exp. 8 T2	Exp. 8 T2	Exp. 8 T2
48		Exp. 8 T3	Exp. 8 T3	Exp. 8 T3
49		Exp. 8 T4	Exp. 8 T4	Exp. 8 T4
50		Exp. 8 T5	Exp. 8 T5	Exp. 8 T5
51		Exp. 9 T1	Exp. 9 T1	Exp. 9 T1
52		Exp. 9 T2	Exp. 9 T2	Exp. 9 T2
53		Exp. 9 T3	Exp. 9 T3	Exp. 9 T3
54		Exp. 9 T4	Exp. 9 T4	Exp. 9 T4
55		Exp. 9 T5	Exp. 9 T5	Exp. 9 T5
56		Exp. 10 T1	Exp. 10 T1	Exp. 10 T1
57		Exp. 10 T2	Exp. 10 T2	Exp. 10 T2
58		Exp. 10 T3	Exp. 10 T3	Exp. 10 T3
59		Exp. 10 T4	Exp. 10 T4	Exp. 10 T4
60		Exp. 10 T5	Exp. 10 T5	Exp. 10 T5

n.	SLiving 515	SLiving 1050	SLiving 10100
61	Keyp. 1 T1	Exp. 11 T1	Exp. 11 T1
62	Keyp. 1 T2	Exp. 11 T2	Exp. 11 T2
63	Keyp. 2 T1	Exp. 11 T3	Exp. 11 T3
64	Keyp. 2 T2	Exp. 11 T4	Exp. 11 T4
65	Keyp. 3 T1	Exp. 11 T5	Exp. 11 T5
66	Keyp. 3 T2	Exp. 12 T1	Exp. 12 T1
67	Keyp. 4 T1	Exp. 12 T2	Exp. 12 T2
68	Keyp. 4 T2	Exp. 12 T3	Exp. 12 T3
69	Keyp. 5 T1	Exp. 12 T4	Exp. 12 T4
70	Keyp. 5 T2	Exp. 12 T5	Exp. 12 T5
71		Exp. 13 T1	Exp. 13 T1
72		Exp. 13 T2	Exp. 13 T2
73		Exp. 13 T3	Exp. 13 T3
74		Exp. 13 T4	Exp. 13 T4
75		Exp. 13 T5	Exp. 13 T5
76		Exp. 14 T1	Exp. 14 T1
77		Exp. 14 T2	Exp. 14 T2
78		Exp. 14 T3	Exp. 14 T3
79		Exp. 14 T4	Exp. 14 T4
80		Exp. 14 T5	Exp. 14 T5
81		Exp. 15 T1	Exp. 15 T1
82		Exp. 15 T2	Exp. 15 T2
83		Exp. 15 T3	Exp. 15 T3
84		Exp. 15 T4	Exp. 15 T4
85		Exp. 15 T5	Exp. 15 T5
86		Exp. 16 T1	Exp. 16 T1
87		Exp. 16 T2	Exp. 16 T2
88		Exp. 16 T3	Exp. 16 T3
89		Exp. 16 T4	Exp. 16 T4
90		Exp. 16 T5	Exp. 16 T5
91		Exp. 17 T1	Exp. 17 T1
92		Exp. 17 T2	Exp. 17 T2
93		Exp. 17 T3	Exp. 17 T3
94		Exp. 17 T4	Exp. 17 T4
95		Exp. 17 T5	Exp. 17 T5
96		Exp. 18 T1	Exp. 18 T1
97		Exp. 18 T2	Exp. 18 T2
98		Exp. 18 T3	Exp. 18 T3
99		Exp. 18 T4	Exp. 18 T4
100		Exp. 18 T5	Exp. 18 T5
101		Exp. 19 T1	Exp. 19 T1
102		Exp. 19 T2	Exp. 19 T2
103		Exp. 19 T3	Exp. 19 T3
104		Exp. 19 T4	Exp. 19 T4
105		Exp. 19 T5	Exp. 19 T5
106		Exp. 20 T1	Exp. 20 T1
107		Exp. 20 T2	Exp. 20 T2
108		Exp. 20 T3	Exp. 20 T3
109		Exp. 20 T4	Exp. 20 T4
110		Exp. 20 T5	Exp. 20 T5
111		Keyp. 1 T1	Exp. 21 T1
112		Keyp. 1 T2	Exp. 21 T2
113		Keyp. 2 T1	Exp. 21 T3
114		Keyp. 2 T2	Exp. 21 T4
115		Keyp. 3 T1	Exp. 21 T5
116		Keyp. 3 T2	Exp. 22 T1
117		Keyp. 4 T1	Exp. 22 T2
118		Keyp. 4 T2	Exp. 22 T3
119		Keyp. 5 T1	Exp. 22 T4
120		Keyp. 5 T2	Exp. 22 T5

n.	SLiving 1050	SLiving 10100
121	Keyp. 6 T1	Exp. 23 T1
122	Keyp. 6 T2	Exp. 23 T2
123	Keyp. 7 T1	Exp. 23 T3
124	Keyp. 7 T2	Exp. 23 T4
125	Keyp. 8 T1	Exp. 23 T5
126	Keyp. 8 T2	Exp. 24 T1
127	Keyp. 9 T1	Exp. 24 T2
128	Keyp. 9 T2	Exp. 24 T3
129	Keyp. 10 T1	Exp. 24 T4
130	Keyp. 10 T2	Exp. 24 T5
131		Exp. 25 T1
132		Exp. 25 T2
133		Exp. 25 T3
134		Exp. 25 T4
135		Exp. 25 T5
136		Exp. 26 T1
137		Exp. 26 T2
138		Exp. 26 T3
139		Exp. 26 T4
140		Exp. 26 T5
141		Exp. 27 T1
142		Exp. 27 T2
143		Exp. 27 T3
144		Exp. 27 T4
145		Exp. 27 T5
146		Exp. 28 T1
147		Exp. 28 T2
148		Exp. 28 T3
149		Exp. 28 T4
150		Exp. 28 T5
151		Exp. 29 T1
152		Exp. 29 T2
153		Exp. 29 T3
154		Exp. 29 T4
155		Exp. 29 T5
156		Exp. 30 T1
157		Exp. 30 T2
158		Exp. 30 T3
159		Exp. 30 T4
160		Exp. 30 T5
161		Exp. 31 T1
162		Exp. 31 T2
163		Exp. 31 T3
164		Exp. 31 T4
165		Exp. 31 T5
166		Exp. 32 T1
167		Exp. 32 T2
168		Exp. 32 T3
169		Exp. 32 T4
170		Exp. 32 T5
171		Exp. 33 T1
172		Exp. 33 T2
173		Exp. 33 T3
174		Exp. 33 T4
175		Exp. 33 T5
176		Exp. 34 T1
177		Exp. 34 T2
178		Exp. 34 T3
179		Exp. 34 T4
180		Exp. 34 T5

n.	SLiving 10100
181	Exp. 35 T1
182	Exp. 35 T2
183	Exp. 35 T3
184	Exp. 35 T4
185	Exp. 35 T5
186	Exp. 36 T1
187	Exp. 36 T2
188	Exp. 36 T3
189	Exp. 36 T4
190	Exp. 36 T5
191	Exp. 37 T1
192	Exp. 37 T2
193	Exp. 37 T3
194	Exp. 37 T4
195	Exp. 37 T5
196	Exp. 38 T1
197	Exp. 38 T2
198	Exp. 38 T3
199	Exp. 38 T4
200	Exp. 38 T5
201	Exp. 39 T1
202	Exp. 39 T2
203	Exp. 39 T3
204	Exp. 39 T4
205	Exp. 39 T5
206	Exp. 40 T1
207	Exp. 40 T2
208	Exp. 40 T3
209	Exp. 40 T4
210	Exp. 40 T5
211	Keyp. 1 T1
212	Keyp. 1 T2
213	Keyp. 2 T1
214	Keyp. 2 T2
215	Keyp. 3 T1
216	Keyp. 3 T2
217	Keyp. 4 T1
218	Keyp. 4 T2
219	Keyp. 5 T1
220	Keyp. 5 T2
221	Keyp. 6 T1
222	Keyp. 6 T2
223	Keyp. 7 T1
224	Keyp. 7 T2
225	Keyp. 8 T1
226	Keyp. 8 T2
227	Keyp. 9 T1
228	Keyp. 9 T2
229	Keyp. 10 T1
230	Keyp. 10 T2
231	Keyp. 11 T1
232	Keyp. 11 T2
233	Keyp. 12 T1
234	Keyp. 12 T2
235	Keyp. 13 T1
236	Keyp. 13 T2
237	Keyp. 14 T1
238	Keyp. 14 T2
239	Keyp. 15 T1
240	Keyp. 15 T2

# Appendix F

## COMBINATION OF OUTPUTS TRIGGERED BY EVENTS

This appendix shows the event-generated actions (activations/deactivations) of the outputs programmed in the "Outputs" and "Other outputs" sections combined with the "SirenSound types" of the sounderflashers on the BUS.

Table 43: **Output typology**

Symbol/Initials	Description
<b>TM</b>	Output on terminal/Relay/OC1/OC2 - monostable
<b>TB</b>	Output on terminal/Relay/OC1/OC2 - bistable
<b>SM</b>	Sounderflasher output with limited flasher time
<b>SB</b>	Sounderflasher output with unlimited flasher time

Table 44: **Functioning and deactivation of the outputs**

Symbol/Initials	Description
<b>A</b>	These outputs will deactivate if a Stop alarm, Reset partition or Disarm operation is carried out while the monostable time of the main output is running.
<b>B</b>	These outputs will deactivate only when the event clears after expiry of the monostable time of the main output.
<b>C</b>	These outputs, due to the continuous flasher function, will not deactivate automatically. In order to deactivate the SB flashers of the sounderflasher after expiry of the monostable time applied to the main output, you must: <ul style="list-style-type: none"> <li>• trigger an event which applies a Stop pattern to the SB flashers</li> <li>• reset the partition</li> </ul>
<b>D</b>	These outputs will deactivate only when the event clears.
<b>E</b>	These outputs will deactivate if, when an event is active, a Stop alarm operation, reset or disarm partition command operation is carried out.
<b>F</b>	These outputs, due to the continuous flasher function, will not deactivate automatically. In order to deactivate the SB flashers of the device on termination of the event, you must: <ul style="list-style-type: none"> <li>• trigger an event which applies a Stop pattern to the SB flashers</li> <li>• reset the partition</li> </ul>
<b>G</b>	These outputs will deactivate when the respective monostable time expires

Table 45: **Output combinations**

Event groups	Principal output				Other outputs			
	TM	TB	SM	SB	TM	TB	SM	SB
Zone Alarm terminal tamper partition alarm partition tamper	<b>A G</b>				<b>A G</b>	<b>A B</b>	<b>A G</b>	<b>A C</b>
		<b>D E</b>			<b>E G</b>	<b>D G</b>	<b>E G</b>	<b>F</b>
			<b>A G</b>		<b>A G</b>	<b>A B</b>	<b>A G</b>	<b>A C</b>
				<b>F</b>	<b>E G</b>	<b>D G</b>	<b>E G</b>	<b>F</b>
Control panel open Dislodged panel Expansion tamper/loss Keypad tamper/loss Reader tamper/loss Sounderflasher tamper/loss Jamming Wireless zone loss Telephone line down	<b>A G</b>				<b>A G</b>	<b>A D</b>	<b>A G</b>	<b>A C</b>
		<b>D E</b>			<b>E G</b>	<b>D G</b>	<b>E G</b>	<b>C</b>
			<b>A G</b>		<b>A G</b>	<b>A B</b>	<b>A G</b>	<b>A C</b>
				<b>F</b>	<b>E G</b>	<b>D G</b>	<b>E G</b>	<b>C</b>
other events	<b>G</b>				<b>G</b>	<b>B</b>	<b>G</b>	<b>C</b>
		<b>D</b>			<b>G</b>	<b>D</b>	<b>G</b>	<b>F</b>
			<b>G</b>		<b>G</b>	<b>B</b>	<b>G</b>	<b>C</b>
				<b>F</b>	<b>G</b>	<b>C</b>	<b>G</b>	<b>C</b>

# Appendix G

## COMPLIANCY WITH THE REGULATIONS IN FORCE



In order to guarantee compliancy with the regulations in force, you must adhere to the following guidelines:

- nBy/X readers must be equipped with devices which protect them against the forced-opening and dislodgement of their casings from their locations, in compliance with Level 2, as indicated in paragraph 3-2-5 *Installing nBy/X readers*.
- The Tamper NO dislodgement-tamper-protection device of the control panel must be installed.
- JOY, nCode and Concept keypads must be equipped with enabled tamper-protection devices, as indicated in paragraph 3-3-1 *Addressing the keypads*.
- FLEX5/U expansion boards must be either mounted inside the metal enclosure of the 1050L or 10100L control panel, or equipped with devices which protect them against the forced-opening of their casings and dislodgement from their locations, in compliance with Performance level 2.
- The lines relating to the intrusion-detection zones must be configured as 'Double balancing' with double EOL resistors, or as Single balancing with single EOL resistor. They must also be equipped with devices which protect them against the forced-opening of their casings.
- Terminal tamper, peripheral tamper and control-panel tamper events must trigger audible signals (sounder signals) for a period of not less than 3 minutes.
- The output activated by the previously mentioned tamper events must be different from the output activated by alarms signals.
- All Code PINs must have 6 digits.
- If a Timer is used for automatic-arming operations, the Pre-arm times must be programmed separately for each partition (the Pre-arm time must not be set at 0).

In particular, in order to guarantee CEI 79-2 compliancy of devices, the following options must be programmed as follows.

### CEI 79-2

- The following options must not be activated in the "Panel Options" section:
  - ReaderBuzzer OFF
  - BypassAlsoTamper
  - OpenZonesArmLock
  - 50131ReaderLedOFF
  - 50131StatHidden
  - 50131IconsHidden
  - 50131AlarDelayed
  - 50131WarnLedMem
- All of the "FaultsNotReady" options - from the "Other parameters" section - must be disabled.
- The "Requires code" option - from the "Keypads - Choose peripheral - Options" section - must be enabled for every keypad and shortcut in use.
- The "Entry Time" parameter of each partition must be no more than 60 seconds.

Compliancy with EN50131 Grade 2 is guaranteed by observing the following guidelines.

### EN50131

- In the "Panel options" section, enable:
  - Keypad lockout
  - OpenZonesArmLock
  - NoUserTamp.reset
  - 50131ReaderLedOFF

- 50131StatHidden
- 50131IconsHidden
- 50131AlarDelayed
- 50131WarnLedMem
- The following options must not be activated in the "Panel Options" section:
  - ReaderBuzzer OFF
  - BypassAlsoTamper
- In the section "Other parameters - FaultNotReady", enable the following options:
  - Zone fuse fault
  - IBUS fuse fault
  - Low battery
  - Mains failure
  - Tel. line down
  - Jamming
  - Low battery WLS
  - WLS zone loss
  - LossTamp.ongoing
- Zones configured as "24H", "Automation" are non-compliant.
- Zones programmed as "Arm", "Disarm", "Switch" or "Follow" comply only when activated by keyswitches with more than 10,000 code combinations.
- An input is set up for system fault management.
- You must delete any programming relating to outdoor sounderflashers - from the respective alarm event in the "Outputs" section - for all zones with the "Fault Zone" attribute. You can programme indoor sounderflashers via the "Other outputs" option.
- The telephone dialer must be enabled.
- The system must include a self-powered sounderflasher for intrusion-alarm event signaling
- If you use a digital dialer or voice dialer with SmartLogos30M board for transmissions, a telephone number must be reserved for the following events:
  - All events generated by zones with the "Hold-up" attribute.
  - All events generated by "Instant", "Delayed", "Delayed unhidden" and "Route"
  - All events generated by terminal, peripheral and control panel tamper.
  - All faults detected by the control panel.
- The "Alarm Cycles" parameter of each zone must be set between 3 and 10.
- The "Mains fail.Delay" parameter must be set at no more than 1 minute.
- The "Requires code" option on the function-key shortcuts must be enabled for all the assigned shortcuts.
- The "StopTelOn Disarm" partition option must not be enabled.
- The "Entry Time" of each partition must be set at a maximum of 45 seconds.
- You must enable the "Priority" option for any alarm events associated with "Hold-up" zones.
- "Failed to arm" and "Forced arming" events must be saved to the Events log.
- The programmed "LowBattery delay" must not be programmed at more than 5 minutes.



# Appendix H

## ORDER CODES

Please quote the following order codes when ordering items from the INIM Electronics product range:

Access Codes	Product description
<b>Air2-BS100</b>	Wireless transceiver
<b>Air2-IRF100</b>	Wireless PIR with 12m coverage
<b>Air2-KF100</b>	4 button remote-control keyfob
<b>Air2-MC100</b>	Wireless magnetic contact with 2 inputs/outputs
<b>AUXREL32</b>	Power distribution relay-board for SmartLiving 1050L and 10100L
<b>Concept/GN</b>	Touch keypad with backlit graphic display and keys equipped with input/output terminal
<b>DCMIINE0SLIVINGE</b>	SmartLiving Installation and Programming Manual
<b>DCMUINE0SLIVINGE</b>	SmartLiving User's Manual
<b>Flex5/P</b>	Two-way Input/Output expansion board in tamper-protected plastic enclosure
<b>Flex5/U</b>	Two-way Input/Output expansion board transparent plastic enclosure with terminal on view
<b>IB100/A</b>	BUS isolator with data and power regeneration and tamper protection
<b>IB100/RP</b>	BUS isolator with data regeneration and tamper protection
<b>IB100/RU</b>	BUS isolator with data regeneration and on-view terminals
<b>Ivy</b>	Self-powered sounderflasher - suitable for outdoor installation
<b>Ivy-B</b>	Self-powered sounderflasher with BUS connection capacity - suitable for outdoor installation
<b>Ivy-BF</b>	Self-powered sounderflasher with BUS connection capacity and foam-tamper protection - suitable for outdoor installation
<b>Ivy-BFM</b>	Self-powered sounderflasher with BUS connection capacity and foam-tamper in metal-look (chrome) enclosure - suitable for outdoor installation
<b>Ivy-BM</b>	Self-powered sounderflasher with BUS connection capacity in metal-look (chrome) enclosure - suitable for outdoor installation
<b>Ivy-F</b>	Self-powered sounderflasher with foam-tamper protection - suitable for outdoor installation
<b>Ivy-FM</b>	Self-powered sounderflasher with foam-tamper protection in metal-look (chrome) enclosure - suitable for outdoor installation
<b>Ivy-M</b>	Self-powered sounderflasher in metal-look (chrome) enclosure - suitable for outdoor installation
<b>Joy/GR</b>	Keypad with backlit graphic display with two input/output terminals
<b>Joy/MAX</b>	Keypad with backlit graphic display with two input/output terminals and built-in proximity reader, microphone, speaker and temperature sensor
<b>LINK232F9F9</b>	RS232 cable link to PC and/or INIM devices
<b>LINKIBUS</b>	Temporary cable link for I-BUS
<b>LINKUSABAB</b>	USB cable link to PC and/or INIM devices
<b>nBy/S</b>	Wall-mount proximity reader
<b>nBy/X</b>	Flush-mount proximity reader
<b>nCard</b>	Card for nBy proximity readers
<b>nCode/G</b>	Keypad with backlit graphic display with one input/output terminal
<b>Nexus</b>	BUS connectable GSM Dialer
<b>nKey</b>	Tag for nBy proximity readers
<b>ProbeTH</b>	Thermal probe for battery-charge optimization
<b>SmartLAN/G</b>	Ethernet interface for programming and internet operations using TCP-IP and UDP protocols
<b>SmartLAN/SI</b>	Ethernet interface for programming via internet using TCP-IP and UDP protocols
<b>SmartLeague software programme</b>	Programming and management software for INIM devices
<b>SmartLink/GWB</b>	SmartLink/G Kit for SmartLiving 1050L and 10100L
<b>SmartLink/REM-ANT</b>	Remote Antenna (3 meters)
<b>SmartLiving10100L</b>	Intrusion control panel: manages 10 to 100 terminals, 15 partitions, switching power supply @5A, optional TCP/IP connectivity, comes in metal enclosure with housing for 1 battery @17Ah
<b>SmartLiving 1050</b>	Intrusion control panel: manages 10 to 50 terminals, 10 partitions, switching power supply @3A, comes in metal enclosure with housing for 1 battery @7Ah
<b>SmartLiving1050L</b>	Intrusion control panel: manages 10 to 50 terminals, 10 partitions, switching power supply @3A, comes in metal enclosure with housing for 1 battery @17Ah
<b>SmartLiving 505</b>	Intrusion control panel: manages 5 terminals, 5 partitions, switching power supply @ 1.2A, comes in metal enclosure with housing for 1 battery @7Ah
<b>SmartLiving515</b>	Intrusion control panel: manages 5 to 10 terminals, 5 partitions, switching power supply @ 1.2A, comes in metal enclosure with housing for 1 battery @7Ah
<b>SmartLogos30M</b>	Voice board (for SmartLiving)
<b>SmartLook</b>	SmartLook is a centralized-control programme for INIM's fire detection and intrusion control systems

<b>SmartModem100</b>	Remote programming modem
<b>SPS12040</b>	Switching power supply/battery charger in enclosure - 3A, 12V
<b>SPS12100</b>	Switching power supply/battery charger in enclosure - 5A, 12V
<b>TamperNO</b>	Dislodgement-tamper device for SmartLiving control panels

## Notes



ISO 9001:2008 Registered company

via Fosso Antico  
Loc. Centobuchi  
63076 Montepandone  
(AP) ITALY

Tel. +39 0735 705007  
Fax +39 0735 704912

info@inim.biz  
[www.inim.biz](http://www.inim.biz)

