



CE

CONTROL PANEL  
FOR 230 V OPERATORS

319S63EN

Z  
SERIES

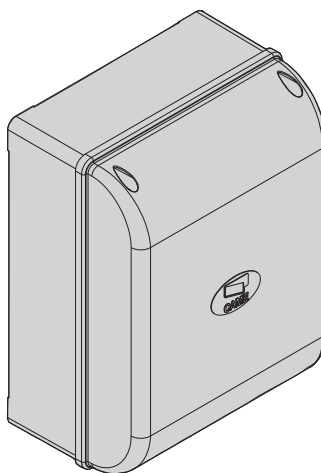

INSTALLATION MANUAL

**ZF1N**



English

EN

## "IMPORTANT INSTALLATION SAFETY INSTRUCTIONS"

"WARNING: IMPROPER INSTALLATION MAY RESULT IN SERIOUS HARM. PLEASE FOLLOW ALL INSTALLATION INSTRUCTIONS"

"THIS MANUAL IS INTENDED ONLY FOR PROFESSIONAL INSTALLERS OR OTHER COMPETENT INDIVIDUALS"



## 1 Legend of symbols



This symbol shows parts which must be read with care.



This symbol means the parts which describe safety issues.



This symbol tells you what to tell the end-user.

## 2 Intended use and limits to use

### 2.1 Intended use

The ZF1N control panel is suitable for swing gate operators of the ATI, FERNI, FAST, KRONO series that powered by 230 V.



Any installation and use other than that specified in this manual is forbidden.

### 2.2 Limits to use

The overall power load of the connected operator must not exceed 320 W.

## 3 Reference standards

Came Cancelli Automatici employs an ISO 9001:14001 certified quality management system and an ISO 14001 environmental management system. Came entirely engineers and manufactures in Italy.

This product is compliant with: *see statement of compliance.*

## 4 Description

Engineered and built entirely by Came Cancelli Automatici S.p.A.

Power supply 230 V AC on terminals L1 and L2. The control panel is protected by a 5 A fuse, while the low voltage accessories (24 V) are protected by a 3.15 A fuse.

Warning! The overall power of the 24 V accessories must not exceed 20 W.

All connections are protected by quick fuses, see table.

The card provides and controls the following functions:

- automatic closing after an opening command;
- maintained action command.

The available command modes are:

- opening/closing;
- total stop.

The photocells, after detecting an obstacle, may trigger:

- the reopening of the closing gate;
- a total stop.

Specific trimmers regulate:

- the working time for automatic closing;
- the delayed closing time of operator 2;
- the working time.

You can also connect:

- 12 V electro-lock
- gate open warning-lamp.

### TECHNICAL DATA

Power supply	230 V - 50/60 Hz
Maximum allowed power load	320 W
Power draw when idle	40 mA
maximum power for 24 V accessories	20W
Circuit insulation class	□
Container material	ABS
Container protection rating	IP54
Working temperature	- 20 / +55°C

### FUSE TABLE

	to protect:	fuses for:
	Electronic board (line)	A 5
	Command devices and accessories (control unit)	3.15A

## 4.1 Dimensions

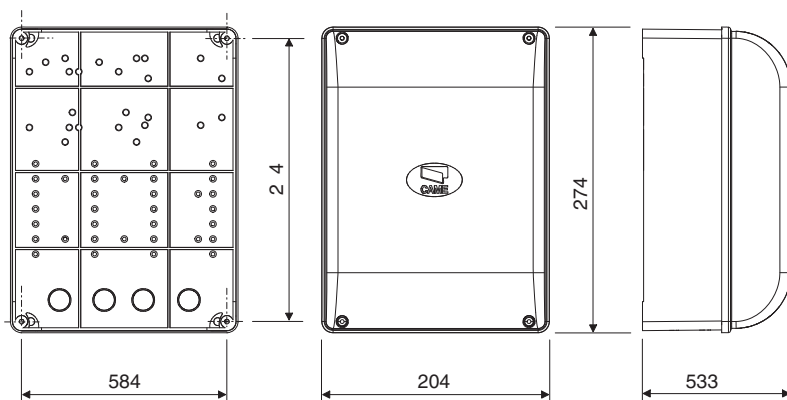

## 4.2 Main components

1. Connecting terminals
2. 5A line fuse
3. 3.15 A accessories fuse
4. Buttons to memorise radio code
5. Trimmer for adjusting the delay of operator 2
6. Working time adjuster trimmer
7. Automatic closing time adjuster trimmer
8. Functions selector
9. Radio frequency card socket
10. LED
11. Operator torque limiter
12. Transformer

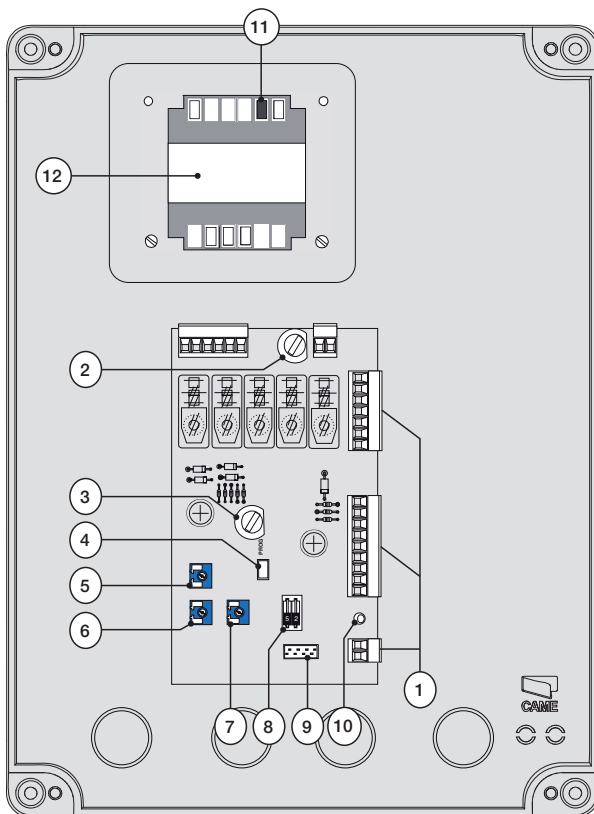

**⚠ Warning!** Before acting on the equipment, cut off the main power supply and disconnect the emergency batteries (if present).

**⚠** Connect the black wires protruding from the card onto condenser connectors.

## 5 Installation

### 5.1 Preliminary checks

**⚠** Before beginning to install, the following is necessary:

- Make sure that the point where the electrical panel is anchored is free from any impacts, and that the surface is solid and that proper tools and materials are used (i.e. screws, wall plugs, etc.).
- Set up a suitable omni polar cut-off device, with distances greater than 3 mm between contacts, with sectioned power source.
- ⚡ Check that any connections inside the container (made for continuity purposes of the protective circuit) are fitted with extra insulation compared to other internal conductive parts.
- Set up proper conduits and electric cable raceways, making sure these are protected from any mechanical damage.

### 5.2 Tools and equipment

Make sure you have all the tools and materials needed to carry out the installation in total safety and in accordance with current regulations. Here are some examples.

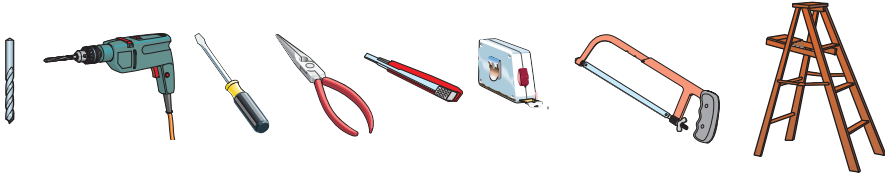

### 5.3 Fastening and mounting the container

1) Secure the base of the panel in a safe area; we suggest using bolts with max. diameter of 6 mm Philips rounded heads.

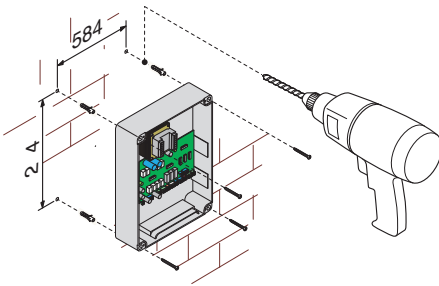

3) After adjusting and setting, secure the cover using the issued screws.

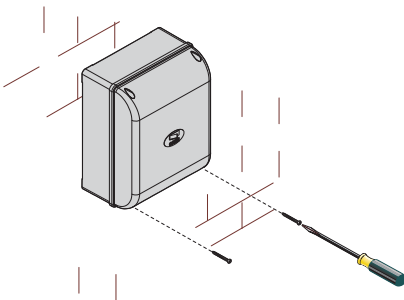

2) Perforate the marked holes and insert the cable glands with corrugated tubes for the electrical cables to run through.

N.B.: the pre-perforated holes have different diameters: 23, 29 and 37 mm.

Careful not to damage the electronic board inside the panel!!

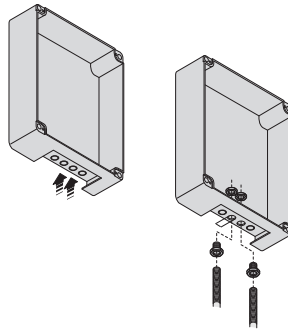

## 6 Electrical connections

### Operator

Operator 1 *delayed when opening*

Operator 2 *delayed when closing*

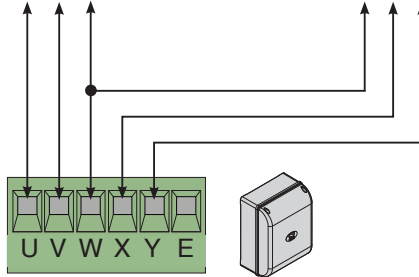

### Power supply

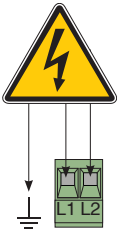

Power supply to the  
230V AC 50/60 Hz  
control panel

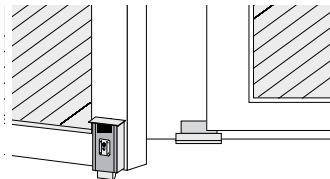

Terminals for powering the  
24V AC accessories. Overall  
allowed power: 20W

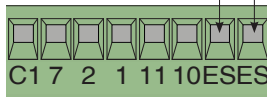

Electro lock connection (12V-15 W max.)

## Warning devices

**Flashing light** (contact rated for: 230V AC - 25W Max.) Flashes while gate opens and closes.

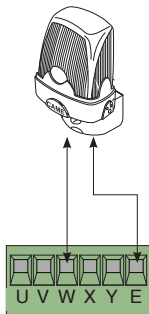

**Gate open warning light** Contact rated for: 24 V - 3 W Max.) Warns of open gate position, turns off when gate is closed.

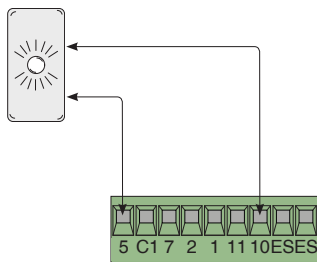

## Safety devices

**C1 = (N.C.) contact** for reopening while closing  
Input for safety devices like photocells, sensitive edges and other devices that comply with EN 12978 regulations. While the door is closing, opening the contact will invert movement until it is fully opened.

if unused, short-circuit contact 2-C1.

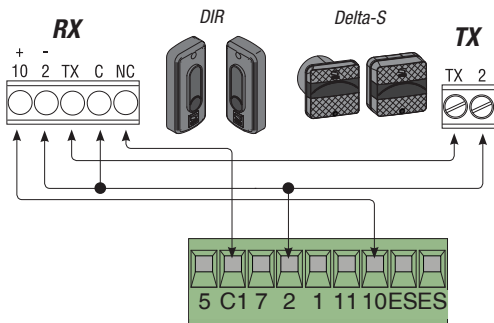
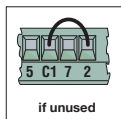

**C1 = (N.C.) contact** for reopening while closing

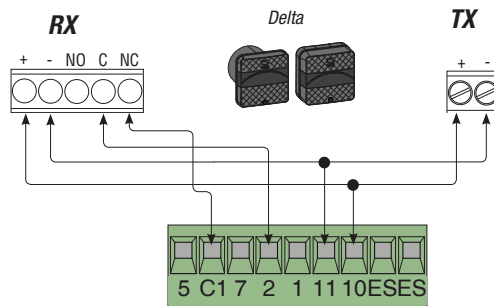

**Stop button (N.C. contact)**

Gate stop button with exclusion of automatic closing, to resume movement press command button or transmitter button.

If unused, short-circuit contact 1-C2.

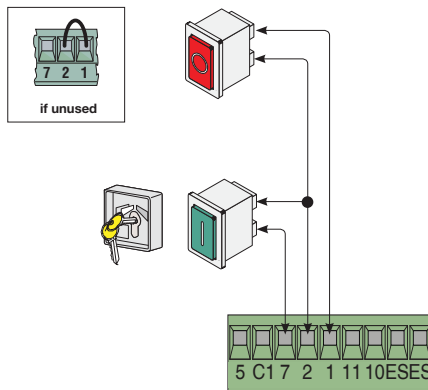

**Key switch selector and/or command button (N.O. contact)**

Commands for opening and closing, by pressing the button or turning the selector switch key.

p. 7 - Manual code: 319569 ver. 2.0 11/2011 © 11/2011 © CAME cancelli automatici s.p.a. - The data and information in this manual may be changed at any time and without obligation on the part of CAME cancelli automatici s.p.a. to notify said changes.

## 7 Selecting functions

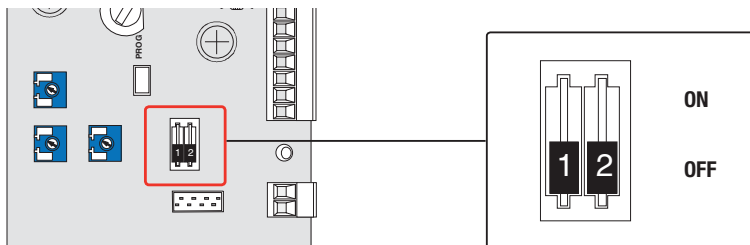

- 1 ON - Automatic closing activated; (10FF - deactivated)
- 2 ON - "Open-stop-close-stop" with (2-7) button and radio transmitter;
- 2 OFF - "Open-close" with button (2-7) and radio transmitter activated.

## 8 Settings

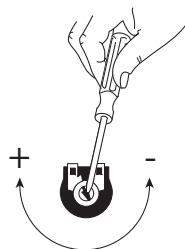
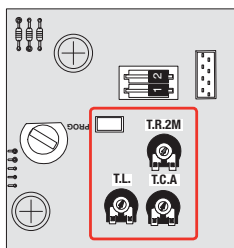

- Trimmer T.R.2M.** = Adjusting the delay of operator 2 from 1 minute to 10 seconds.
- Trimmer T.L.** = Adjusting the working time from 15 seconds to 120 seconds. (Note: adjusting the working time to the minimum will activate the "maintained action" function).
- Trimmer T.C.A.** = Adjusting automatic opening and closing times from 0 seconds to 120 seconds.

## 9 Motor torque limiter

To change motor torque, move the faston (the one with the black wire) to one of the four settings; 1 min. - 4 max.

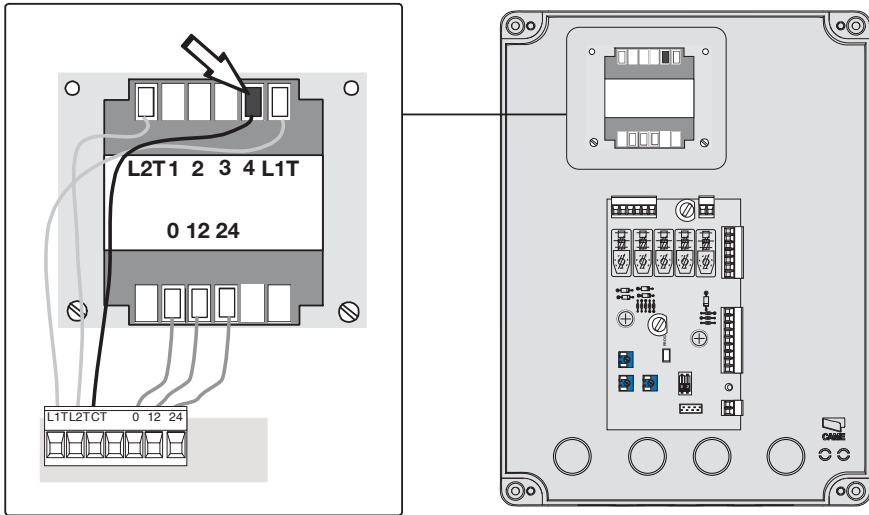

## 10 Activating the radio command

### Antenna

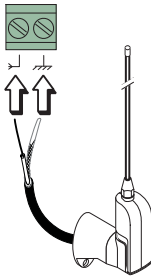

Connect RG58 antenna cable to the apposite terminals.

### Transmitters

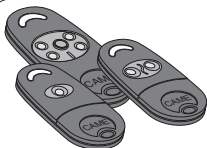

**ATOMO**  
AT01 • AT02  
AT04

see instruction sheet in the packaging  
of the AF43SR radio-frequency card



see instructions on box

**TOUCH**

TCH 4024 • TCH 4048

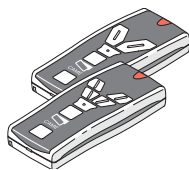

**TOP**

TOP-432A • TOP-434A  
TOP-302A • TOP-304A

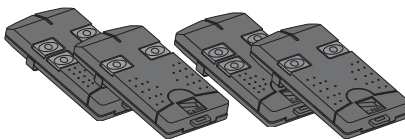

**TOP**

TOP-432NA • TOP-434NA  
TOP-862NA • TOP 864NA  
TOP-432S

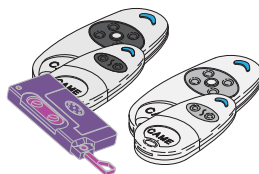

**TWIN**

TWIN 2 • TWIN 4

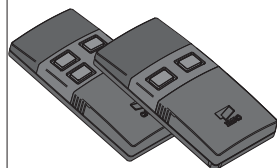

**TAM**

T432 • T434 • T438  
TAM-432SA

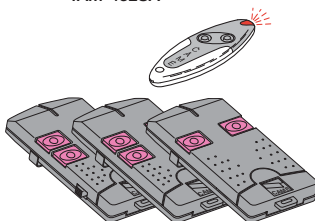

**TFM**

T132 • T134 • T138  
T152 • T154 • T158

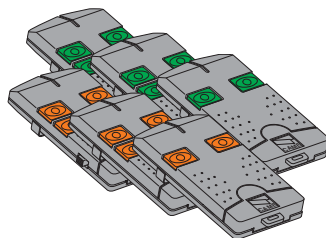

**Radio frequency card**

Only for the AF43S / AF43SM radio-frequency cards.

- position jumper as shown depending on the series of transmitters you are using.

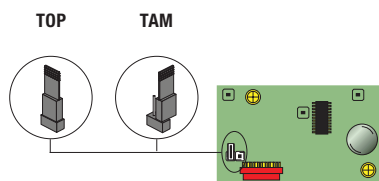

Frequency MHz	Card Radio-frequency	Series transmitters
FM 26.995	AF130	TFM
FM 30.900	AF150	TFM
AM 26.995	AF26	TOP
AM 30.900	AF30	TOP
AM 433.92	AF43S / AF43SM	TAM / TOP
AM 433.92	AF43TW	TWIN (KeyBlock)
AM 433.92	AF43SR	ATOMO
AM 40.685	AF40	TOUCH
AM 863.35	AF868	TOP

Plug in the radio-frequency card onto the electronic board AFTER CUTTING OFF THE MAIN POWER SUPPLY (and disconnecting the emergency batteries).

N.B.: The control board recognises the radio-frequency card only when it is powered up.

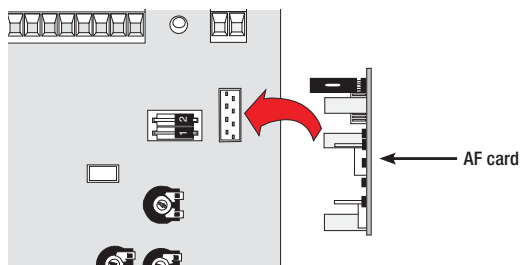

1) Keep pressed the "CH1" button on the control board (the LED light flashes).

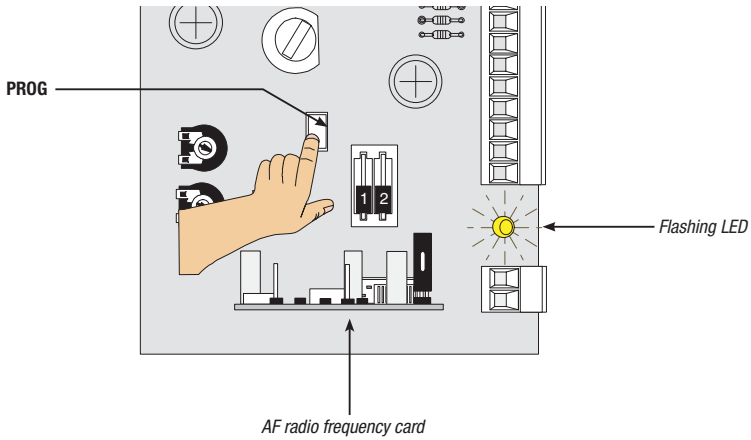

2) The transmitter button sends the code, and the LED will stay on to signal that memorisation was successful.

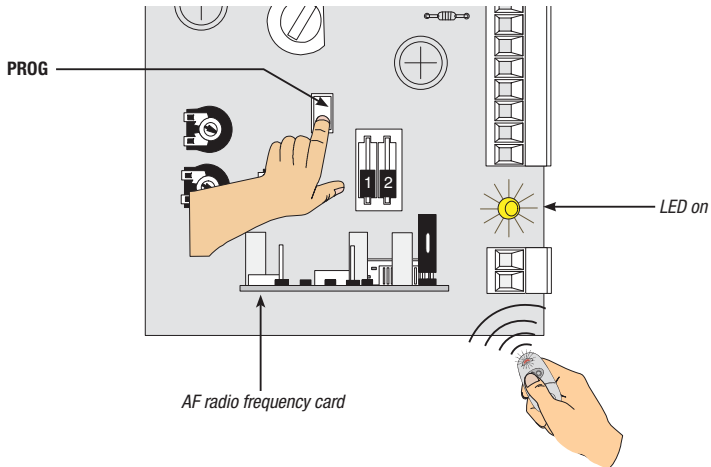

N.B.: if you later wish to change code, repeat the sequence described.

## 11 Dismantling and disposal

 On its premises, CAME Cancelli Automatici S.p.A. implements a certified Environmental Management System in compliance with the UNI EN ISO 14001 standard to ensure environmental protection. Please help us to safeguard the environment. At CAME we believe this to be one of the fundamentals of our market operations and development strategies. Just follow these short disposal instructions:



### DISPOSING OF THE PACKAGING

The components of the packaging (i.e. cardboard, plastic, etc.) are solid urban waste and may be disposed of without much trouble, simply by separating them for recycling.

Before proceeding it is always a good idea to check your local legislation on the matter.

**DO NOT DISPOSE OF IN NATURE!**



### PRODUCT DISPOSAL

Our products are made up of various materials. Most of these (aluminium, plastic, iron, electric cables) are solid urban waste. These can be disposed of at local solid waste management dumps or recycling plants.

Other components (i.e. electronic cards, transmitters batteries, etc.) may contain hazardous substances.

These must therefore be handed over to the specially authorised disposal firms.

Before proceeding it is always a good idea to check your local legislation on the matter.

**DO NOT DISPOSE OF IN NATURE!**

## 12 Compliance statement



### MANUFACTURER'S STATEMENT

*Pursuant to attachment II A of the Directive 2006/95/CE*



**CAME Cancelli Automatici S.p.A.**  
via Martiri della Libert , 15  
31030 Dosson di Casier - Treviso - ITALY  
tel (+39) 0422 4940 - fax (+39) 0422 4941  
internet: [www.came.it](http://www.came.it) - e-mail: [info@came.it](mailto:info@came.it)

--- REGULATIONS ---  
EN 60335-1 EN 61000-6  
EN 60335-2 EN 61000-6  
EN 13241-1

Declares under law that the following garage door and gate automation product called:

#### ZF1N

...comply with the essential requirements and pertinent provisions, established by the following Directives and also comply with the applicable parts of the reference Regulation standards listed below.

---DIRECTIVES---  
2006/95/CE  
2004/108/CE

LOW VOLTAGE DIRECTIVE  
ELECTROMAGNETIC COMPATIBILITY DIRECTIVE

MANAGING DIRECTOR  
Mr Gianni Michielan

Reference code to request an original copy: **DDC L EN Z002**



English - Manual code: 319563 ver. 2.0 1/2011 © CAME cancelli automatici s.p.a. The data and information in this manual may be changed at any time and without obligation on the part of CAME Cancelli Automatici S.p.a. to notify said changes.

<p><b>CAME France S.a.</b> 7, Rue Des Haras Z.i. Des Hautes Patures 92737 <b>Nanterre Cedex</b> ☎ (+33) 0 825 825 874 ☎ (+33) 1 46 13 05 00</p>	FRANCE	GERMANY	<p><b>CAME Gmbh Seefeld</b> Akazienstrasse, 9 16356 <b>Seefeld</b> Bei Berlin ☎ (+49) 33 3988390 ☎ (+49) 33 39883985</p>
<p><b>CAME Automatismos S.a.</b> 3, Rue Odette Jasse 13015 <b>Marseille</b> ☎ (+33) 0 825 825 874 ☎ (+33) 4 91 60 69 05</p>	FRANCE	U.A.E.	<p><b>CAME Gulf Fze</b> Office No: S10122a2o210 P.O. Box 262853 Jebel Ali Free Zone - <b>Dubai</b> ☎ (+971) 4 8860046 ☎ (+971) 4 8860048</p>
<p><b>CAME Automatismos S.a.</b> C/juan De Mariana, N. 17-local 28045 <b>Madrid</b> ☎ (+34) 91 52 85 009 ☎ (+34) 91 46 85 442</p>	SPAIN	RUSSIA	<p><b>CAME Rus Umc Rus Llc</b> Ul. Otradnaya D. 2b, Str. 2, office 219 127273, <b>Moscow</b> ☎ (+7) 495 739 00 69 ☎ (+7) 495 739 00 69 (ext. 226)</p>
<p><b>CAME United Kingdom Ltd.</b> Unit 3 Orchard Business Park Town Street, Sandiacre <b>Nottingham - Ng10 5bp</b> ☎ (+44) 115 9210430 ☎ (+44) 115 9210431</p>	GREAT BRITAIN	PORTUGAL	<p><b>CAME Portugal Ucj Portugal Unipessoal Lda</b> Rua Liebig, nº 23 2830-141 <b>Barreiro</b> ☎ (+351) 21 207 39 67 ☎ (+351) 21 207 39 65</p>
<p><b>CAME Group Benelux S.a.</b> Zoning Ouest 7 7860 <b>Lessines</b> ☎ (+32) 68 333014 ☎ (+32) 68 338019</p>	BELGIUM	INDIA	<p><b>CAME India Automation Solutions Pvt. Ltd</b> A - 10, Green Park 110016 - <b>New Delhi</b> ☎ (+91) 11 64640255/256 ☎ (+91) 2678 3510</p>
<p><b>CAME Americas Automation Llc</b> 11345 NW 122nd St. <b>Medley, FL 33178</b> ☎ (+1) 305 433 3307 ☎ (+1) 305 396 3331</p>	U.S.A	ASIA	<p><b>CAME Asia Pacific</b> 60 Alexandra Terrace #09-09 Block C, The ComTech 118 502 <b>Singapore</b> ☎ (+65) 6275 0249 ☎ (+65) 6274 8426</p>
<p><b>CAME Gmbh</b> Kornwestheimer Str. 37 70825 <b>Korntal</b> Munchingen Bei Stuttgart ☎ (+49) 71 5037830 ☎ (+49) 71 50378383</p>	GERMANY		
<p><b>CAME Cancelli Automatici S.p.a.</b> Via Martiri Della Libert�, 15 31030 <b>Dosson Di Casler</b> (Tv) ☎ (+39) 0422 4940 ☎ (+39) 0422 4941 Informazioni Commerciali 800 848095</p>	ITALY	ITALY	<p><b>CAME Sud s.r.l.</b> Via F. Imparato, 198 Centro Mercato 2, Lotto A/7 80146 <b>Napoli</b> ☎ (+39) 081 7524455 ☎ (+39) 081 7529190</p>
<p><b>CAME Service Italia S.r.l.</b> Via Della Pace, 28 31030 <b>Dosson Di Casler</b> (Tv) ☎ (+39) 0422 383532 ☎ (+39) 0422 490044 <b>Assistenza Tecnica 800 295830</b></p>	ITALY	ITALY	<p><b>CAME Global Utilities s.r.l.</b> Via E. Fermi, 31 20060 <b>Gessato</b> (Mi) ☎ (+39) 02 95380366 ☎ (+39) 02 95380224</p>

