

*AUTOMATION FOR STREET BARRIERS*

# GARD 4 SERIES

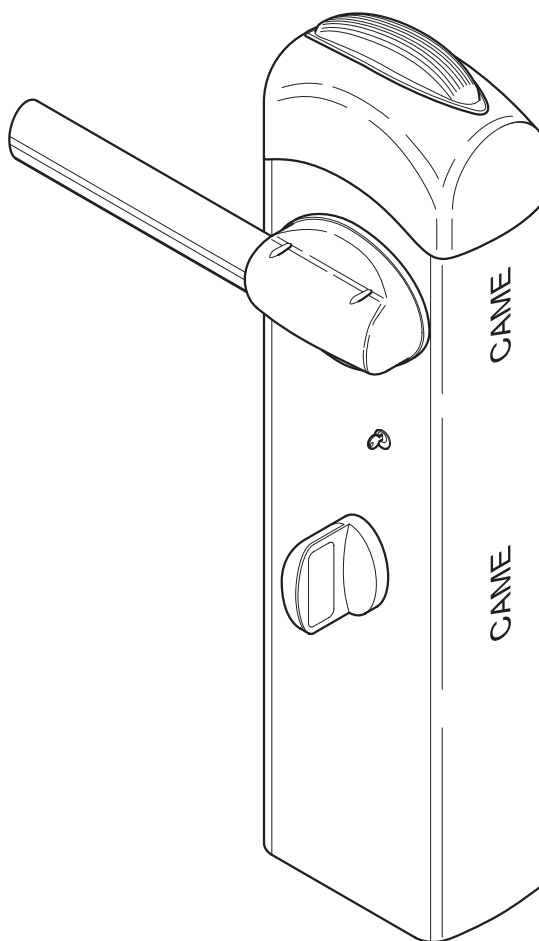

INSTALLATION MANUAL

***G4040 - G4040I***

## "IMPORTANT SAFETY INSTRUCTIONS FOR INSTALLATION"

"CAUTION: IMPROPER INSTALLATION MAY CAUSE SERIOUS DAMAGE, FOLLOW ALL INSTALLATION INSTRUCTIONS CAREFULLY"

"THIS MANUAL IS ONLY FOR PROFESSIONAL INSTALLERS OR QUALIFIED PERSONS"

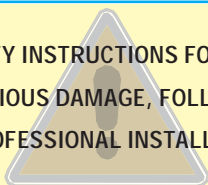

## 1 Legend



This symbol indicates sections to be read with particular care.



This symbol indicates sections concerning safety



This symbol indicates notes to communicate to users.

## 2 Destination and limits of use

### 2.1 Destination

The GARD 4 automatic barrier was designed for use in private or public car parks, in residential areas or in highly trafficked areas.



The use of this product for purposes other than as described above and installation executed in a manner other than as instructed in this technical manual are prohibited.

### 2.2 Limits of use

Passage width of up to 3.75 meters with a 2- to 6-second aperture time.

## 3 Standard followed

The following standards were complied with for this product: EN 12978, UNI EN 954-1, CEI EN 60335-1, UNI EN 12453.

## 4 Description

### 4.1 Gearmotor

GARD 4 was designed and manufactured by CAME CANCELLI AUTOMATICI S.p.A. and is compliant with safety regulations in force. Guaranteed 24 months if not tampered with.

The cabinet is made of 2.5 mm painted galvanized steel or 2 mm AISI 304 satin-finish stainless steel. Inside the cabinet, the electromechanical gearmotor operates with a container for electric board and transformer. Built with an anti-shearing safety system, it includes a safety contact in the inspection hatch lock and in the emergency release lock.

There are two versions of the GARD 4 model:

G4040 - painted galvanized steel automatic barrier with a 24V DC gearmotor and container for board and transformer;

G4040I - satin-finish AISI 304 stainless steel automatic barrier with 24V DC gearmotor and container for board and transformer;

The GARD 4 automation system is supplied with the following accessories:

001 G03750 - L. 4m semi-oval aluminium bar, painted white, with slot cover and shock-resistant profile;

001 G03752 - L. 4m oval aluminium bar, painted white, with slot cover;

001 G02040 - Ø 40 (yellow) balancing spring;

001 G04060 - Ø 50 (green) balancing spring;

001 G06080 - Ø 55 (red) balancing spring;

003 ZL38 - Electric board designed to accommodate radio board coupling;

002 LB38 - Board for the connection of three 12V-6Ah emergency batteries;

The following accessories are optional to the GARD 4 automation system:

001 G02801 - Flashing dome lamp;

001 G02802 - Support for mounting the photoelectric cell (DIR) onto the cabinet (not applicable to barriers with bar and rack and/or mobile foot);

001 G03751 - Emergency battery housing support;

001 G02803 - Luminous cord for movement signalling;

001 G02804 - Luminous cord connecting cable;

001 G02807 - Fixed barrier support;

001 G02808 - Mobile barrier support;

001 G02809 - Red reflector strips (package of 20);

001 G0465 - Painted aluminium rack in 2m modules;

**Important!** Check that the safety equipment and accessories are CAME originals; this is a guarantee that also makes the system easy to set up and upkeep.

All the data and information contained herein is considered subject to change at any time and at our discretion

## 4.2 Technical information

### GEARMOTOR

Power supply: 230V A.C. 50/60Hz  
 Motor power supply: 24V D.C. 50/60Hz  
 Max. absorption: 1.3A (230V) / 15A (24V)  
 Rated power: 300W  
 Max. torque: 600 Nm  
 Reduction ratio: 1/202

Opening time: 2÷6 s  
 Operative intermittence: intensive operation  
 Protection level: IP54  
 Weight: 54 kg  
 Insulation class: I



## 4.3 Parts description

### AUTOMATION UNIT

- 1) Upper dome
- 2) Bar beam plate
- 3) Bar fitting intermediate plate
- 4) Cover for semioval aluminium bar
- 5) Anti-shearing protection cover
- 6) Sheet-steel or stainless steel cabinet with galvanized and painted finish
- 7) Inspection hatch
- 8) Gearmotor
- 9) ABS container for electric board with transformer

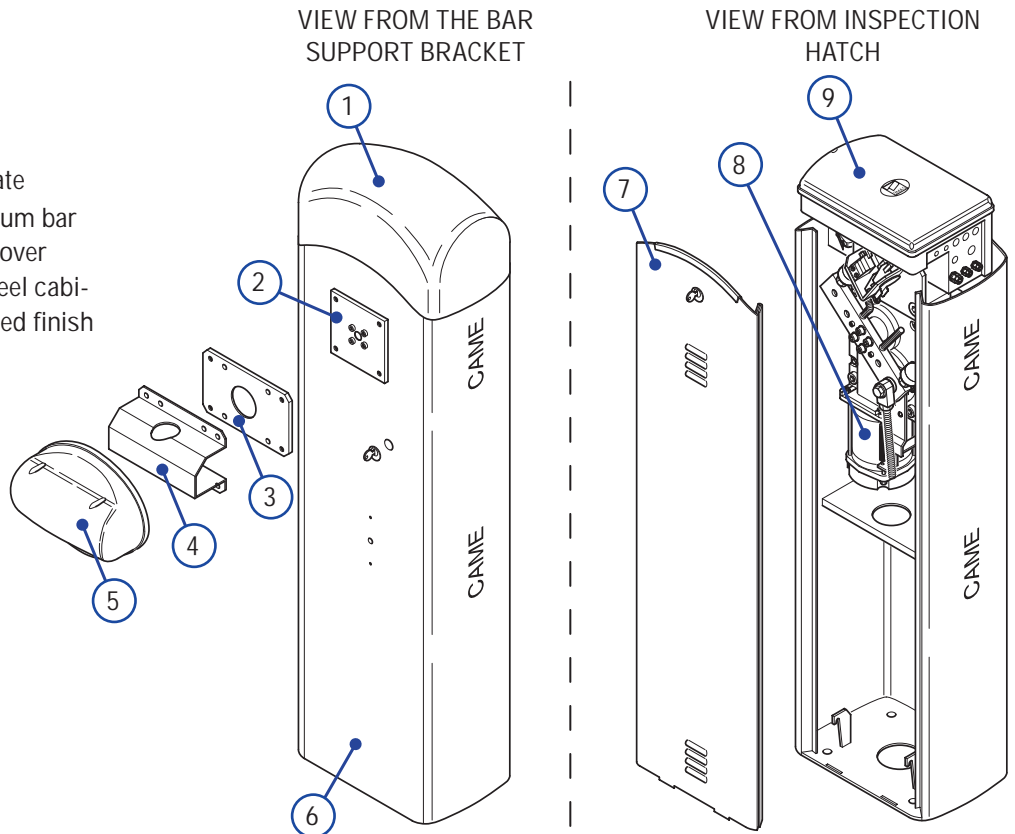

### ACCESSORIES

- 1) G03750 - Semioval aluminium bar, painted white L = 4 m.
- 2) G03752 - Oval aluminium bar, painted white L = 4 m.
- 3) G02040 - Ø40 (yellow) balancing spring
- 4) G04060 - Ø50 (green) balancing spring
- 5) G06080 - Ø55 (red) balancing spring
- 6) G0465 - Rack
- 7) G02802 - Support for DIR photoelectric cells
- 8) G02803 - Luminous cord
- 9) G02807 - Fixed barrier support
- 10) G02808 - Mobile barrier support
- 11) G02809 - Adhesive reflector strips
- 12) G02801 - Flashing dome lamp
- 13) G03751 - Emergency battery housing support
- 14) ZL38 - Electric board designed to accommodate radio board coupling
- 15) G03753 - cover for oval aluminium bar

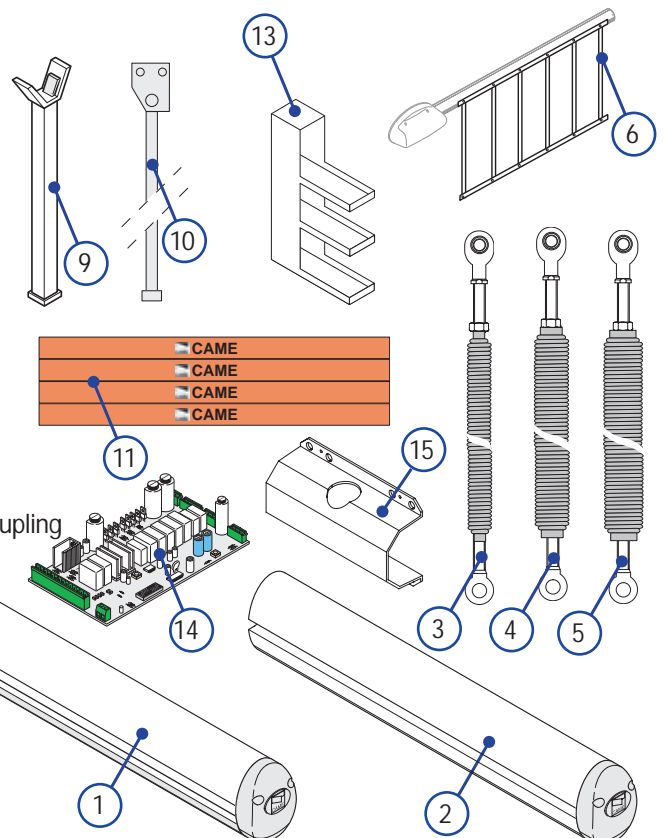

All the data and information contained herein is considered subject to change at any time and at our discretion

## 4.4 Size measurements

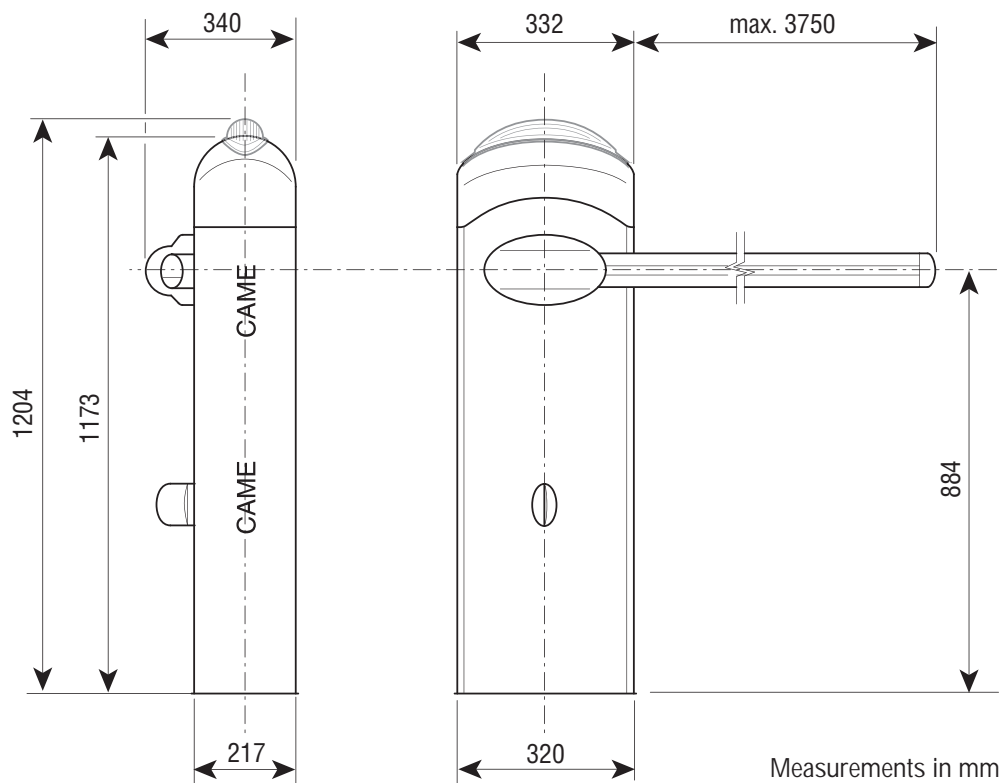

## 5 Installation

**⚠** Installation must be carried out by expert qualified personnel and in full observance of regulations in force.

### 5.1 Preliminary checks

**⚠** Before proceeding with the installation, it is necessary to:

- Make sure the area selected for the mounting of the base and for the unit itself presents no hazards;
- Provide for suitable omnipolar disconnection device with more than 3 mm between contacts to section power supply.
- ⚡ Connections inside the case made for protection circuit continuity are allowed as long as they include additional insulation with respect to other internal drive parts.
- Install suitable tubes and ducts for electric cable passage to guarantee protection against mechanical damage.

### 5.2 Tools and materials

Make sure all tools and materials necessary are within reach to install the edge in maximum safety, according to regulations in force. The following figure illustrates the minimum equipment for the installer.

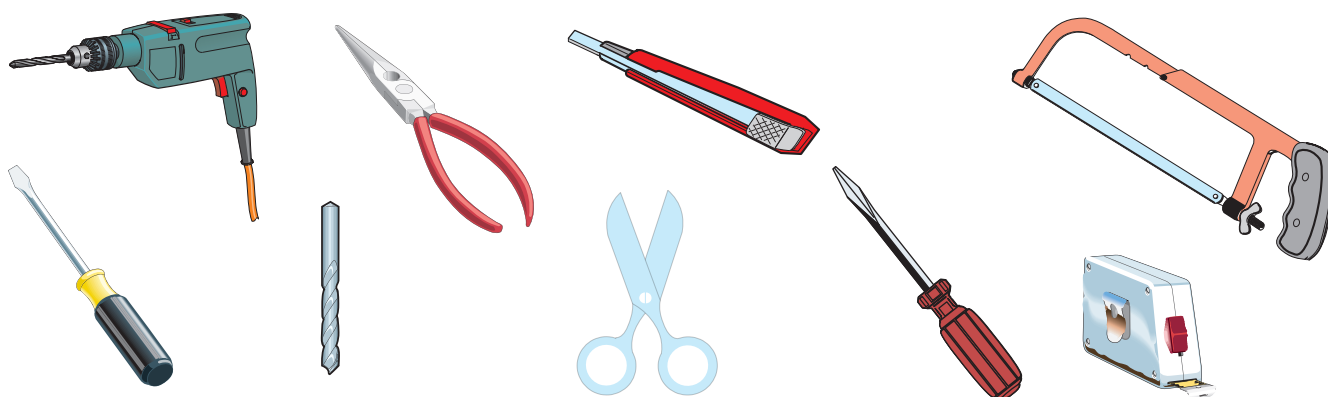

### 5.3 Cable list and minimum thickness

Connections	Type of cable	Length of cable 1 < 10 m	Length of cable 10 < 20 m	Length of cable 20 < 30 m
230V 2F power supply	FROR CEI 20-22  CEI EN 50267-2-1	3G x 1,5 mm <sup>2</sup>	3G x 2,5 mm <sup>2</sup>	3G x 4 mm <sup>2</sup>
24V motor power supply		2 x 1 mm <sup>2</sup>	2 x 1,5 mm <sup>2</sup>	2 x 2,5 mm <sup>2</sup>
24V - 230V flashing lamp		2 x 0,5 mm <sup>2</sup>	2 x 1 mm <sup>2</sup>	2 x 1,5 mm <sup>2</sup>
Photoelectric cells TX		2 x 0,5 mm <sup>2</sup>	2 x 0,5 mm <sup>2</sup>	2 x 0,5 mm <sup>2</sup>
Photoelectric cells RX		4 x 0,5 mm <sup>2</sup>	4 x 0,5 mm <sup>2</sup>	4 x 0,5 mm <sup>2</sup>
24V power supply accessory		2 x 0,5 mm <sup>2</sup>	2 x 0,5 mm <sup>2</sup>	2 x 1 mm <sup>2</sup>
Control button		2 x 0,5 mm <sup>2</sup>	2 x 0,5 mm <sup>2</sup>	2 x 0,5 mm <sup>2</sup>
End stop		3 x 0,5 mm <sup>2</sup>	3 x 1 mm <sup>2</sup>	3 x 1,5 mm <sup>2</sup>
Antenna connection	RG58	max. 10 m		
Metallic mass detector	(see documents provided with product)			

N.B.: An evaluation of the size of the cables with lengths other than the data in the table must be made based on the effective absorption of the connected devices, according to the instructions indicated by the CEI EN 60204-1 standards. For connections that require several loads on the same line (sequential), the size given on the table must be re-evaluated based on actual absorption and distances.

All the data and information contained herein is considered subject to change at any time and at our discretion

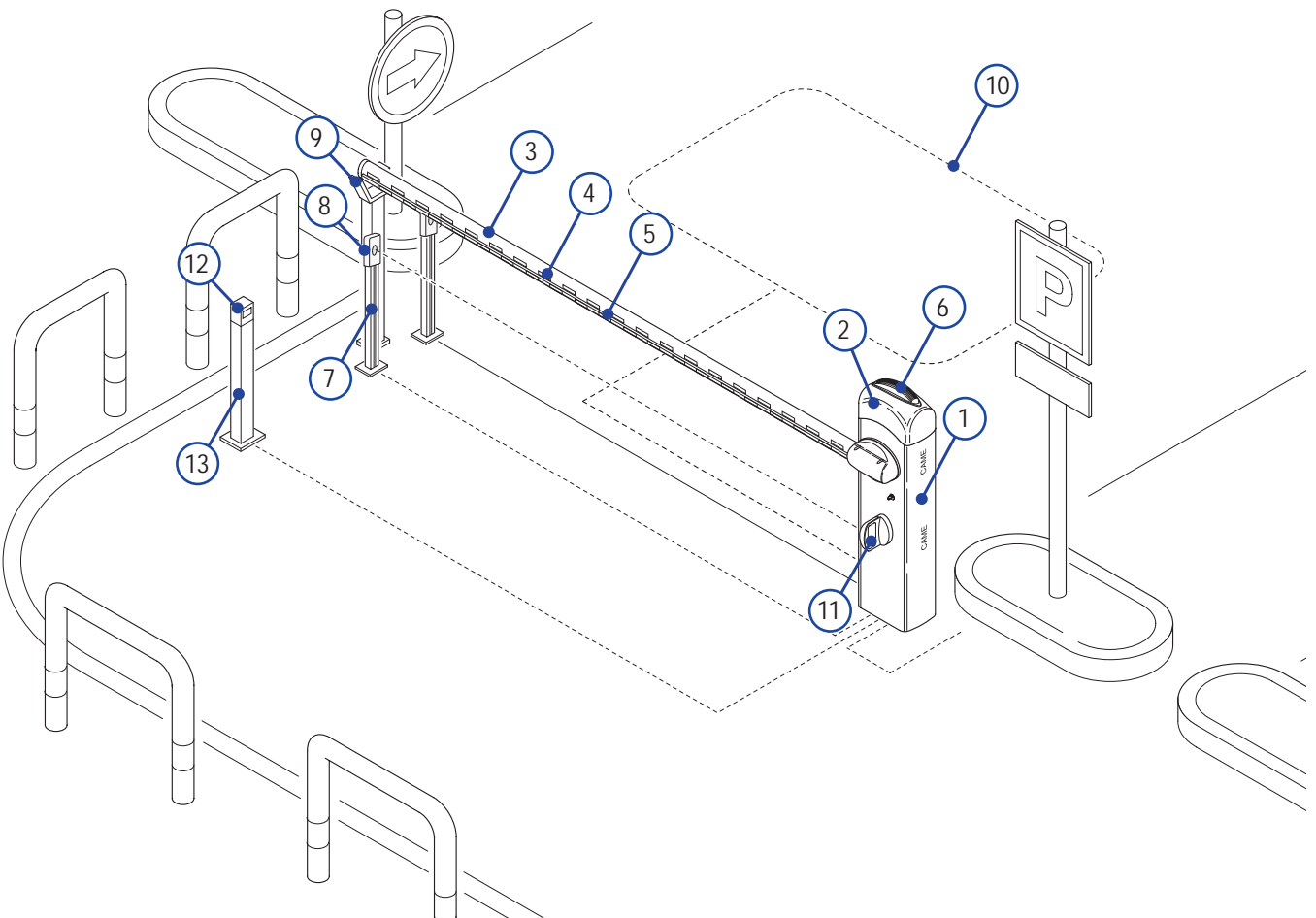

- |                                       |                                 |
|---------------------------------------|---------------------------------|
| 1 - GARD unit                         | 8 - Photoelectric cells         |
| 2 - Control panel                     | 9 - Fixed barrier support       |
| 3 - Aluminium bar                     | 10 - Magnetic sensor            |
| 4 - Red phosphorescent strips         | 11 - Photoelectric cell support |
| 5 - Luminous cord                     | 12 - Magnetic reader            |
| 6 - Movement-indicating flashing lamp | 13 - Column for reader          |
| 7 - Column for photoelectric cells    |                                 |

## 5.4 Fitting for unit base

 The following applications are only examples, as the space required for unit installation and the accessories vary depending on dimensions and therefore it is up to the installer to select the best solution.

1) Prepare a hole to house the fixing base and prepare sheath tubes from the branch pit for the connections.

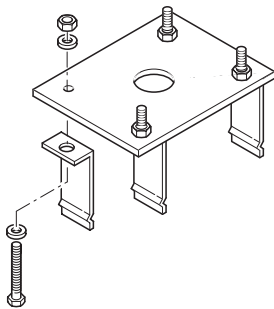
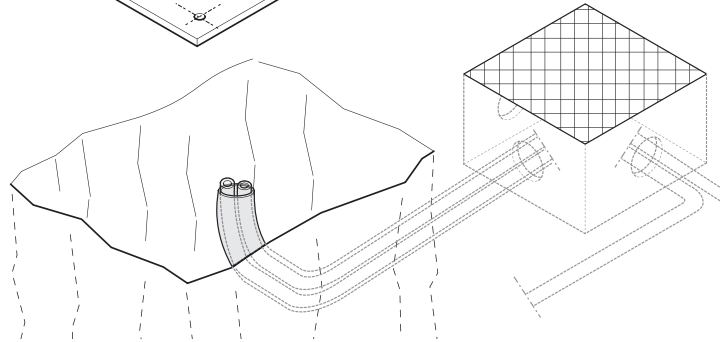
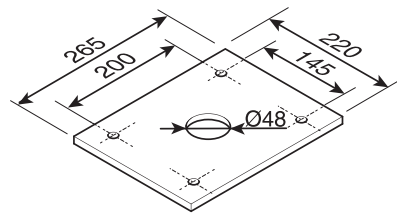

2) Assemble the four anchoring clamps at the base.

3) Fill the hole with concrete and immerge the clamps and the fixing base, paying particular attention to the sheath tube which must go through the hole at the base. The base must be perfectly level, clean and with the screw threads fully on the surface.

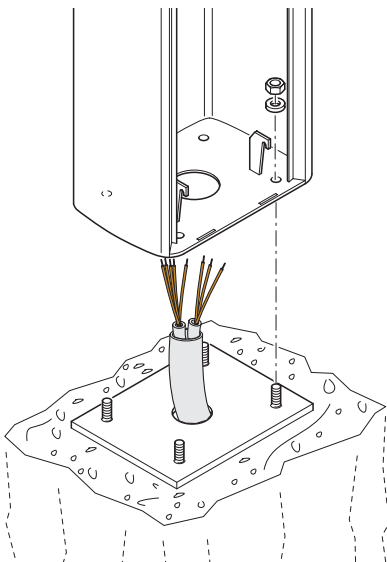
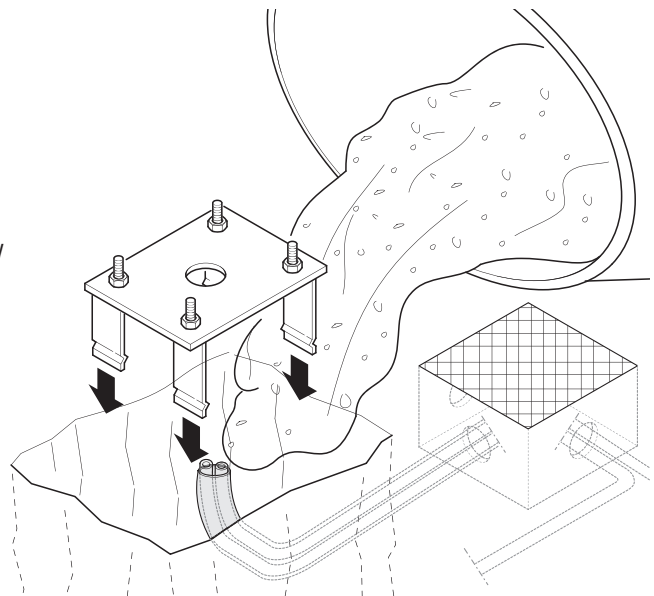

4) Remove the nuts and washers from the threaded screws, position the cabinet on the base in correspondence with the 4 threaded screws and secure with the nuts and washers.

Note: We recommend installing the cabinet with the inspection hatch facing the internal area.

All the data and information contained herein is considered subject to change at any time and at our discretion

## 5.5 Installation of the Unit

1) Remove the two screws at the upper dome's side and lift it. Insert the customised key in the lock, turn it counter-clockwise and remove the hatch from the cabinet.

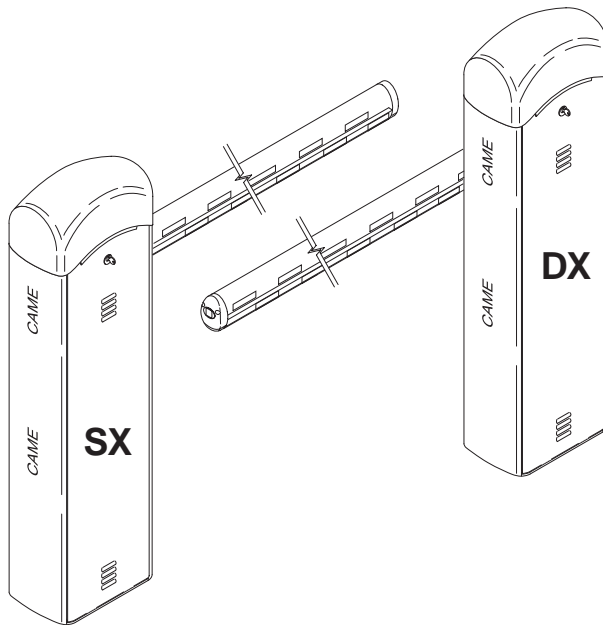
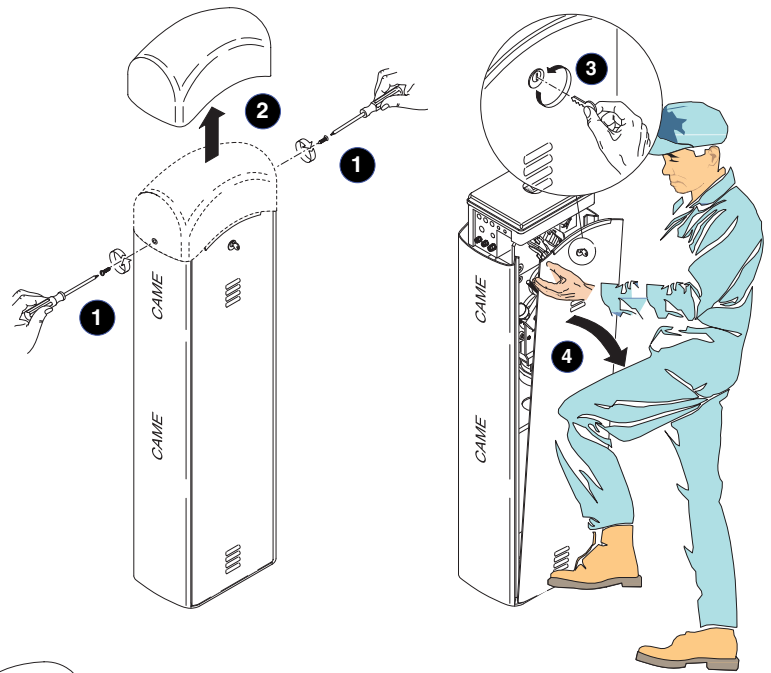

2) The barrier is designed to be installed on the left of the gateway as seen from inside.

3) Should installation on the right be required, the direction of the bar's opening must be inverted. Proceed in the following manner:

- remove the anchor bolt for springs from the transmission arm;
- release the gearmotor with the key;
- turn the transmission arm around;
- secure the gearmotor again;
- secure the anchor bolt to the transmission arm's opposite hole;
- invert the motor phase on terminals M and N;
- invert the end stop wires on terminals FA and FC.

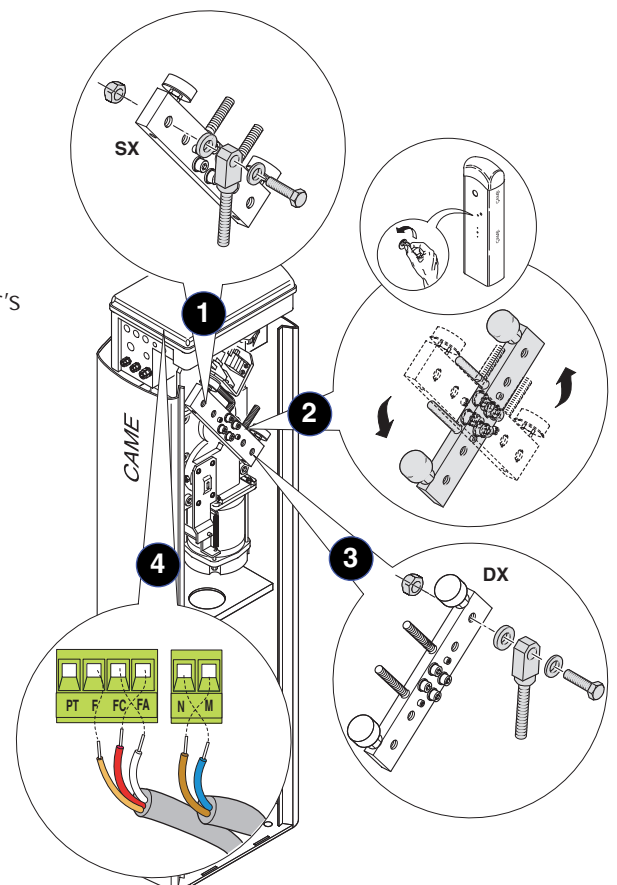



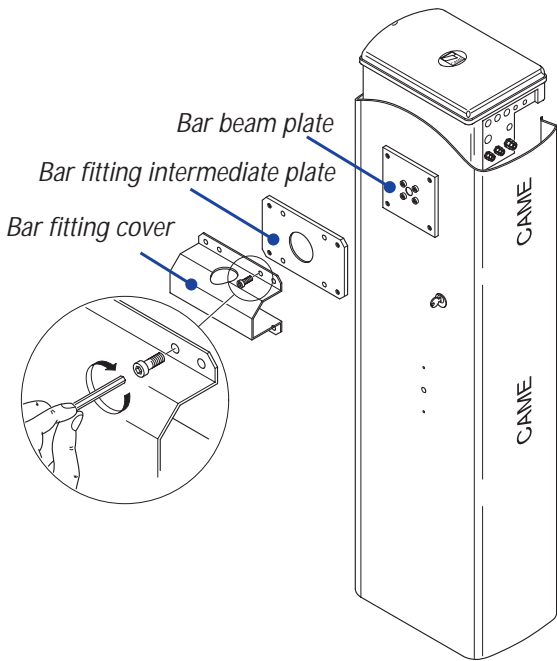

4) Position the middle plate between the fitting plate and the bar-fitting cover, and put in one UNI 5931 M8x20 screw without tightening it to facilitate bar assembly.

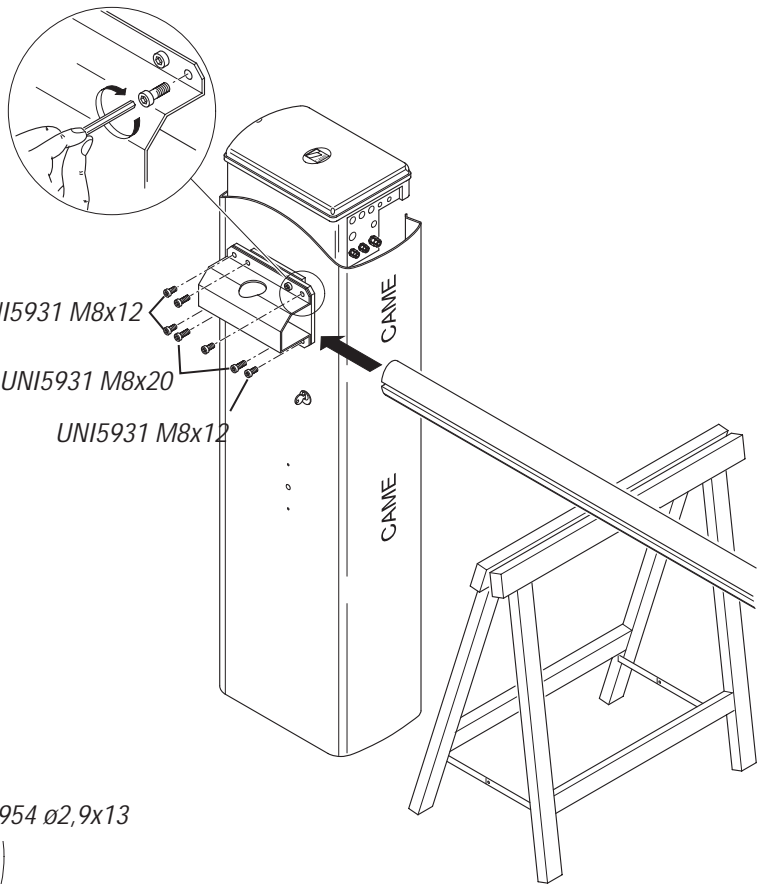

5) Insert the bar in the fitting cover and secure it with UNI 5931 M8x20 and M8x12 screws.

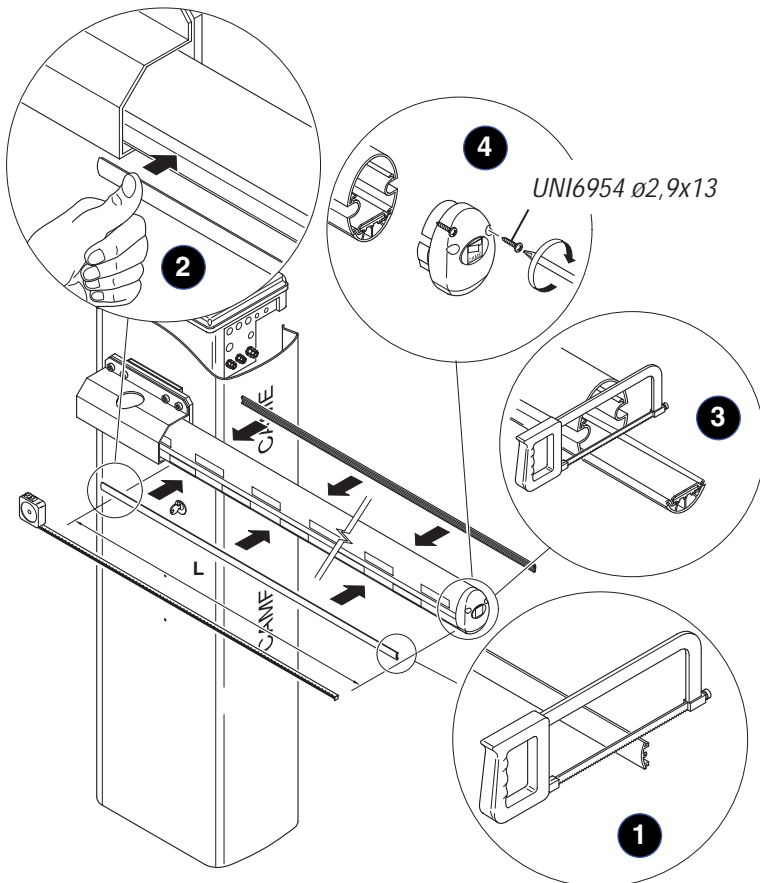

6) Measure the length of the bar, cut the bar slot to the same length and insert it in the bar's conduit, a procedure that should be carried out on both sides. Insert the shock-resistant profile and cut excess length. Lastly, secure the bar end plug with the screws provided.



7) Tighten the anti-shearing protection cover to the bar fitting with UNI6954 Ø3.9x19 screws.

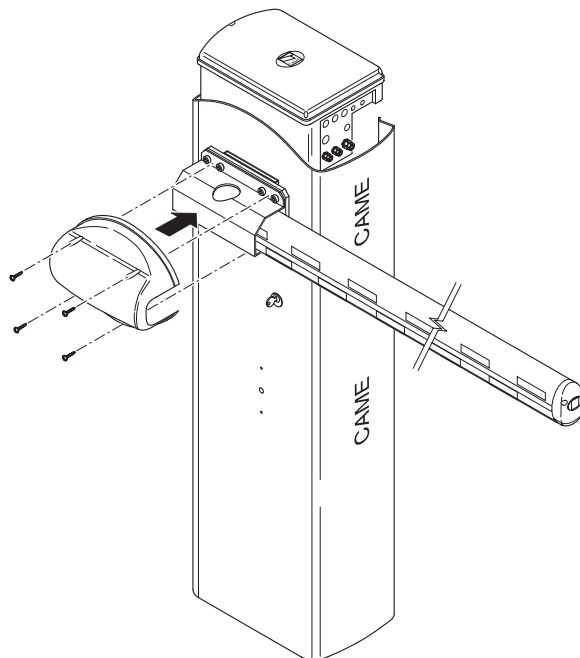

### 5.6 Bar balancing

1) Prior to bar balancing, select a suitable spring depending on the situation at hand. See table below.

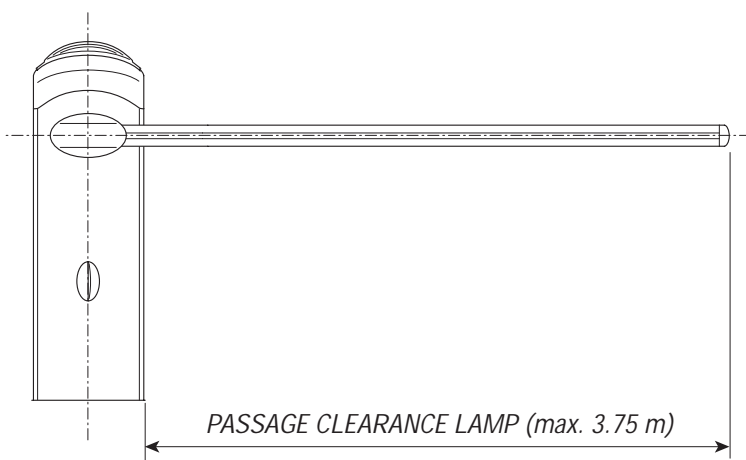

- G02040 spring  $\varnothing_e = 40 \text{ mm}$
- G04060 spring  $\varnothing_e = 50 \text{ mm}$
- G06080 spring  $\varnothing_e = 55 \text{ mm}$

Passage clearance lamp (m)

	1.5	1.75	2.0	2.25	2.5	2.75	3.0	3.25	3.5	3.75
Bare bar* + shock-resistant profile	Yellow	Yellow	Yellow	Yellow	Yellow	Green	Green	Red	Red	Red
Bare bar* + shock-resistant profile and luminous cord	Yellow	Yellow	Yellow	Green	Green	Green	Green	Red	Red	Red
Bare bar* + rack	Yellow	Green	Green	Green	Green	Green	Red	Red	Red	Red
Bare bar* + luminous cord and rack	Yellow	Green	Green	Green	Green	Green	Red	Red	Red	Red
Bare bar* + shock-resistant profile and mobile barrier support	Yellow	Green	Green	Green	Green	Green	Red	Red	Red	Red
Bare bar* + shock-resistant profile, luminous cord and mobile barrier support	Yellow	Green	Green	Green	Green	Green	Red	Red	Red	Red
Bare bar* + rack and mobile barrier support	Yellow	Green	Green	Green	Green	Green	Red	Red	Red	/
Bare bar* + luminous cord, rack and mobile barrier support	Yellow	Green	Green	Green	Green	Green	Red	Red	Red	/

\* By Bare bar we mean a bar complete with the transparent slot cover and end plug.

2) Release the gearmotor and position the bar vertically, and then refasten the gearmotor.

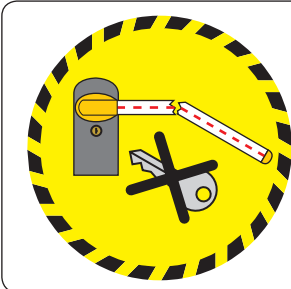

**⚠ WARNING!** The release procedure may constitute a hazard for the user when, for whatever reason – the bar is fixed improperly to the housing during assembly, or the bar is cracked or broken in an accident, and so on – the tension springs no longer provide balance! These can thus cause a brusque rotation of the bar attachment and/or of the bar itself.

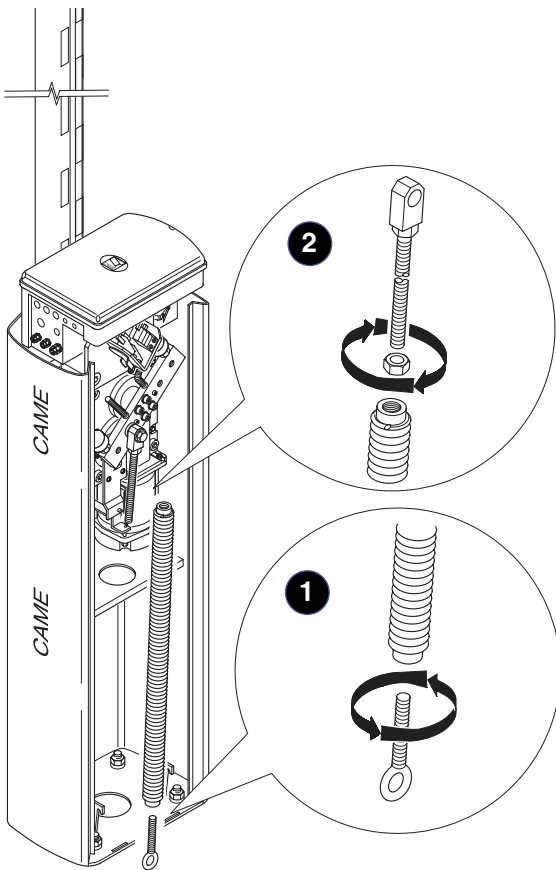
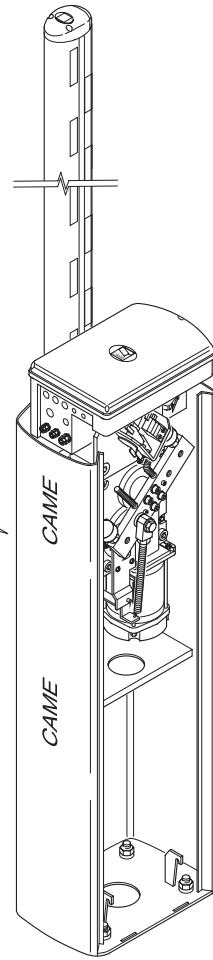

3) Tighten the tie rod to the spring and then the top part of the spring to the anchor bolt with an anchor nut.

4) Hook the tie rod to the anchoring bracket, release the gearmotor and manually turn the spring to increase or decrease traction until the bar rests at 45°.

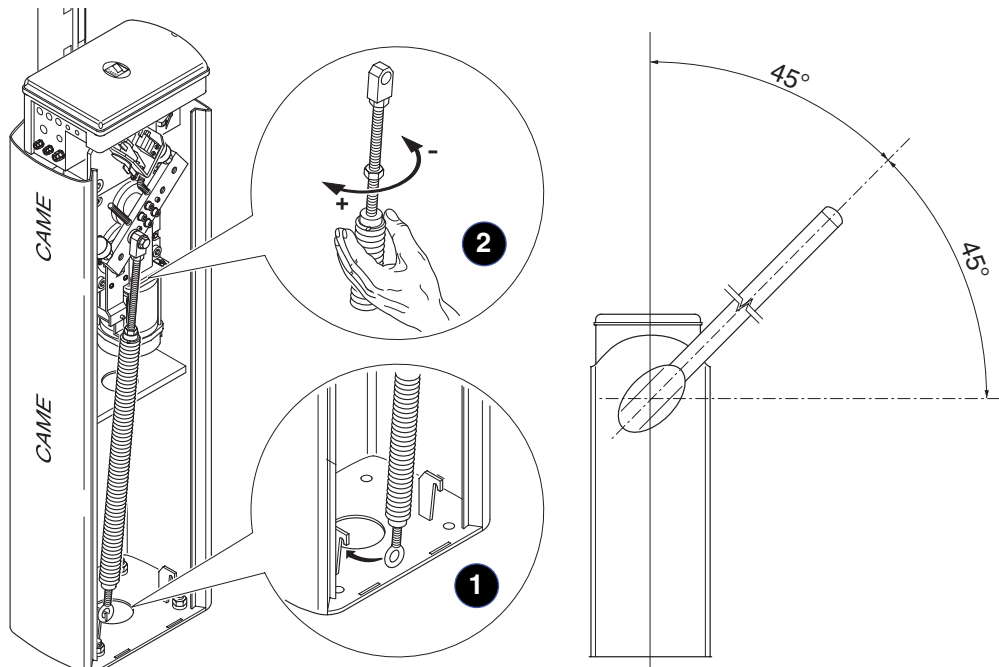

All the data and information contained herein is considered subject to change at any time and at our discretion

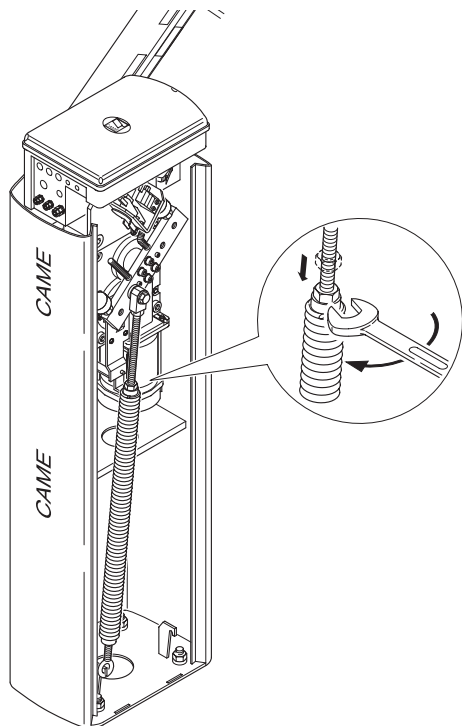

5) Tighten the blocking nut and refasten the gearmotor.

Note: make sure the spring functions properly:

- the spring is loose when the bar is in the vertical position (at rest)
- the spring is tight when the bar is in the horizontal position (tense).

### 5.7 ZL38 Electric board installation

1) Loosen the three screws in the container cover located in the upper part of the unit.

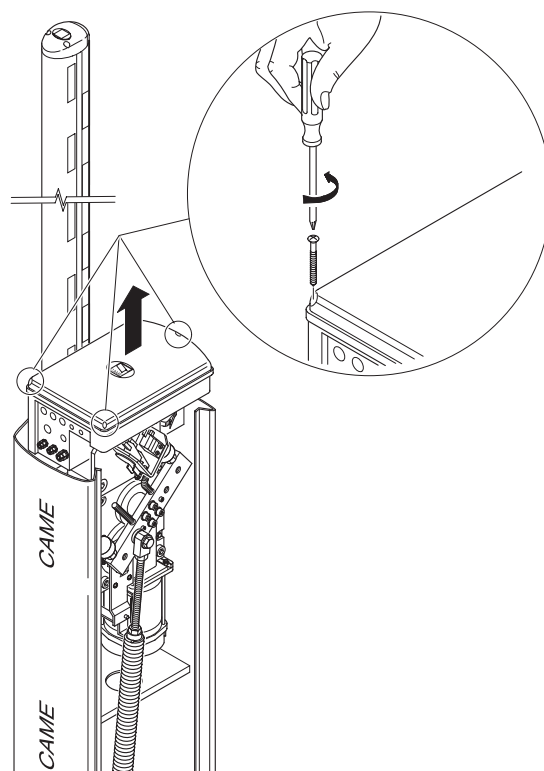
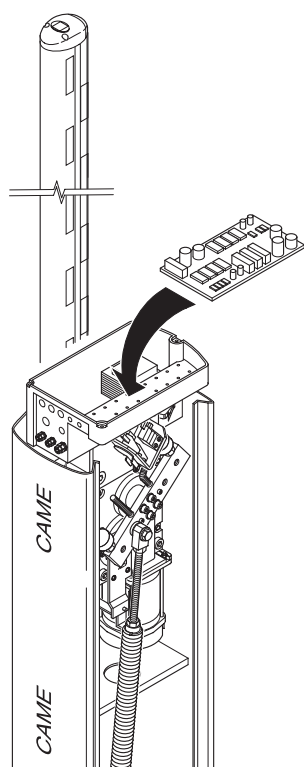

2) Insert the board in the container and fasten it with the screws provided; carry out all the electrical connections (see the dedicated technical documentation enclosed with the board).

## 5.8 End stop adjustment

Power up the electric board, carry out a series of steps to make sure of the bar's correct opening and closing positions, and then, if necessary, proceed to the adjustment of the dampers.

**Warning!** For greater safety and better unit performance, the bar's opening and closing operations should be carried out with the inspection hatch closed!

1) Execute the closing operation, adjust the open bar's position by turning the free damper clockwise (to increase the bar's run) or counter-clockwise (to decrease the run). Adjustment of the position with a  $\sim 89^\circ$  aperture from the closed position is recommended.

**Warning!** The bar's stop position is preceded by the slowing phase by means of a tab and spring system that activates the slowing-down microswitch prior to the bar's total stop.

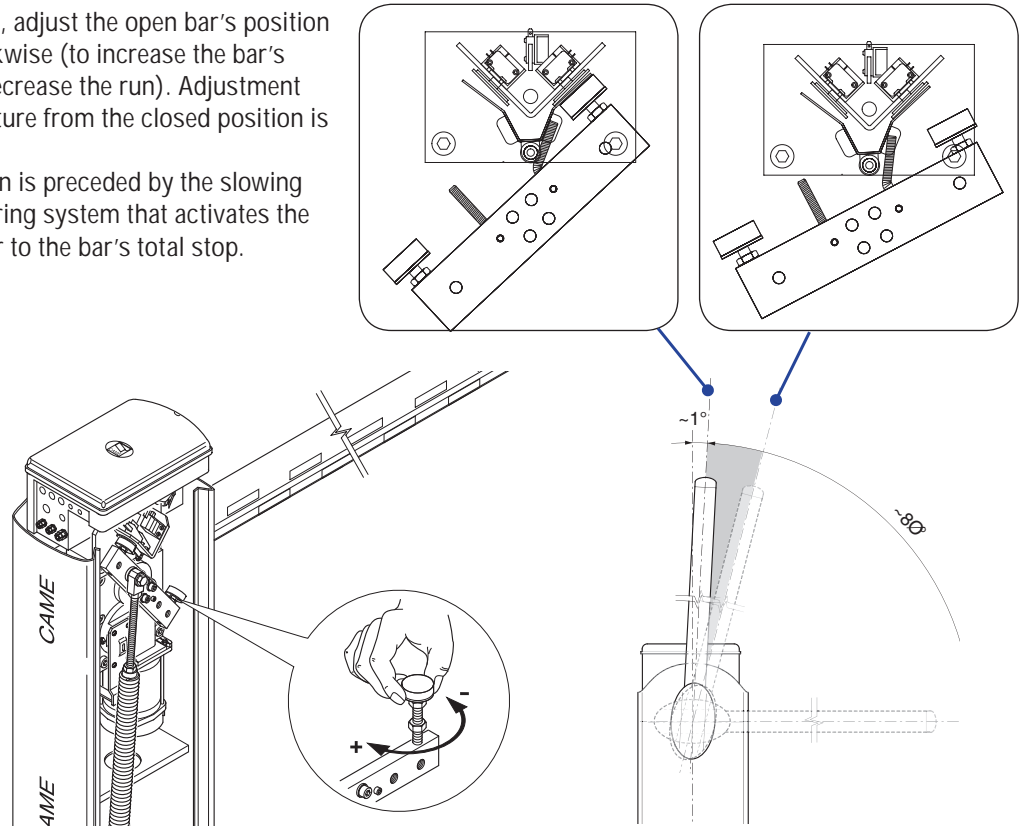

2) The procedure is similar for the bar's opening position. Adjust the closure damper screw until a position parallel to the road surface is reached.

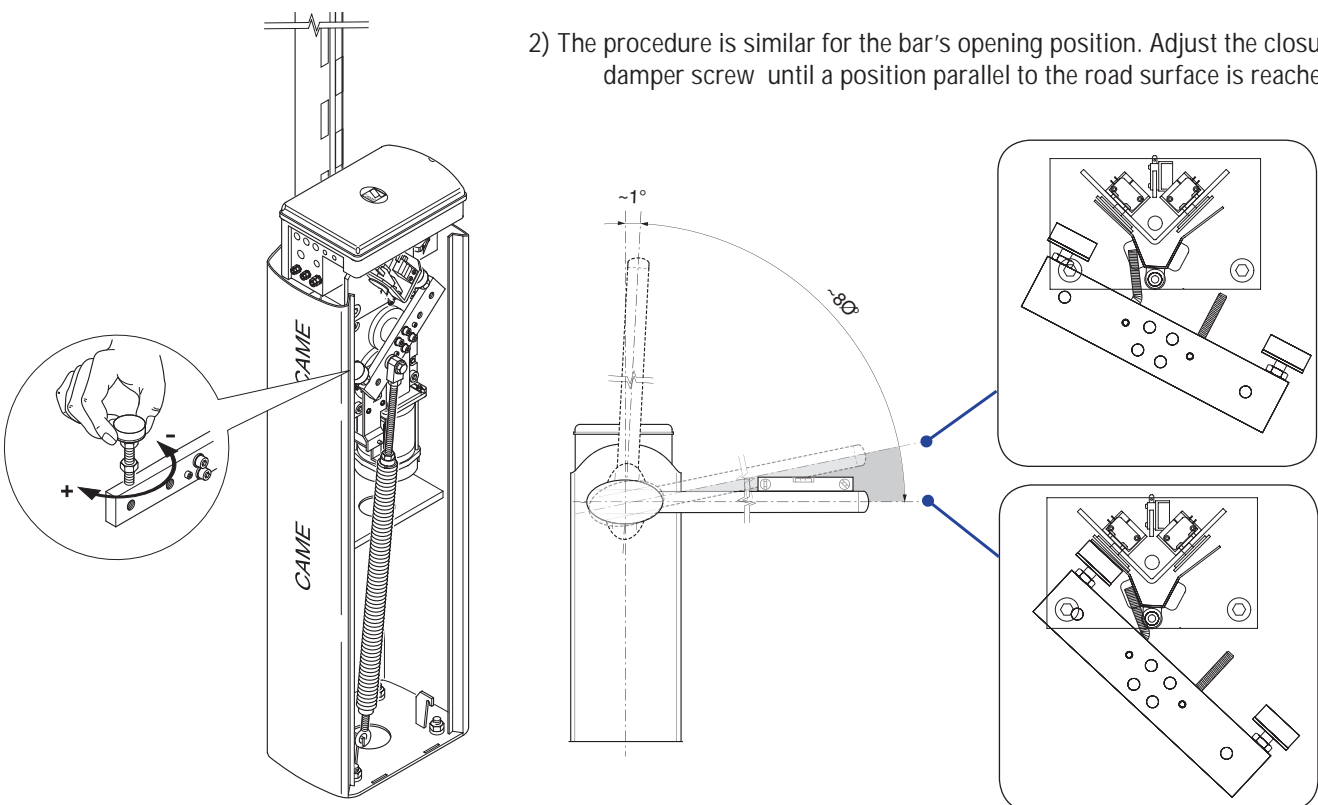

All the data and information contained herein is considered subject to change at any time and at our discretion

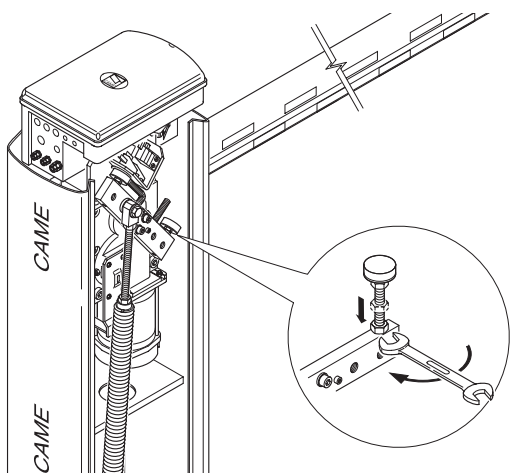

3) After bar opening and closing adjustment, tighten the locking nuts under the dampers.

4) After making adjustments and settings from the control panel, put the container lid in place and secure with screws.

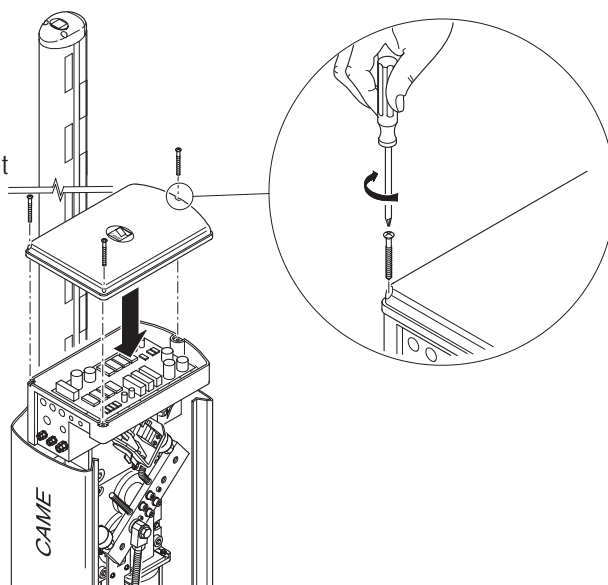

5) Insert the inspection hatch and close it.

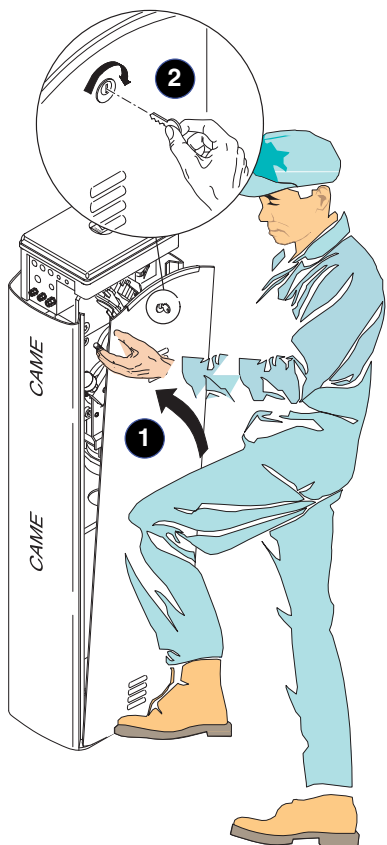

6) Insert the protection dome on the upper part of the unit and secure with the two UNI6954 Ø3.9x13 screws provided.

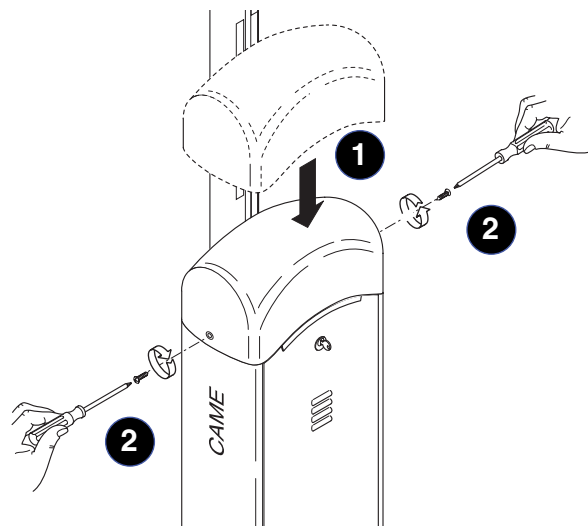

All the data and information contained herein is considered subject to change at any time and at our discretion

## 6 Maintenance

### 6.1 Periodic maintenance

 The unit does not require specific maintenance. Only as a precautionary measure and in case of intensive use, we recommend periodic checks (every 6 months) on the state of the electric wire connected to the motor, the spring-bar balance, the tightness of the nuts and the proper oiling of the sliding points between fixed and mobile parts.

All checks must be recorded (in a dedicated record-book).

### 6.2 Problem solving

MALFUNCTIONS	REFERENCES	CHECKS
The unit neither opens nor shuts	1-2-3-4-6-8-18	1 – Close the inspection hatch with the key and check the release lock
The unit opens but does not close	4-7-10	2 - Disable “steady movement” with dipswitch
The unit shuts but does not open	4-7-9	3 – Check power supply and fuses
No automatic closure	11-12-13	4 - N.C. safety contacts open (1-2 / 2-C1 / 2-C5)
The unit does not work if the remote control is used	2-14-16	6 - Disable master-slave function
The unit inverts direction	7-18	7 – Check spring tension and balancing
The unit works only with remote control	22	8 – Disable obstacle detection with dipswitch
The photoelectric cell does not react	12-23-24	9 – Check if end stop opens
The signalling LED indicator flashes rapidly	4	10 – Check if end stop closes
The signalling LED indicator remains on	13	11 - Activate “automatic closure” dip switch
The unit does not end its run	7	12 – Check the correct direction of movement
The bar is not properly balanced	7-15	13 - (2-3 / 2-4 / 2-7) command button
The unit does not slow down	7-15	14 –Check jumper on AF43S, turn on/off power
The unit does not work with the back-up batteries	8-25-26	15 – Check the bar length ratio with mountable accessories
The unit is slow to respond	7	16 – Re-save radio code
		18 – Adjust sensitivity
		22 - Enter or duplicate the same code in all the remote controls
		23 – Activate the photoelectric cell with the dipswitch
		24 – Connect the photoelectric cells in a series, not in parallel
		25 – Dead batteries
		26 –Respect the photoelectric cells' polarity

## 7 Demolition and disposal

 In its premises, CAME CANCELLI AUTOMATICI S.p.A. implements an Environmental Management System certified in compliance with the UNI EN ISO 14001 standard to ensure environmental protection.

Please continue our efforts to protect the environment—which CAME considers one of the cardinal elements in the development of its operational and market strategies—simply by observing brief recommendations as regards disposal:

 **DISPOSAL OF PACKAGING** – The packaging components (cardboard, plastic, etc.) are all classifiable as solid urban waste products and may be disposed of easily, keeping in mind recycling possibilities.

Prior to disposal, it is always advisable to check specific regulations in force in the place of installation.

#### **PLEASE DISPOSE OF PROPERLY!**

 **PRODUCT DISPOSAL** – Our products are made up of various types of materials. Most of them (aluminium, plastics, iron, electrical wires, etc.) may be disposed of in normal garbage collection bins and can be recycled by disposing of in specific recyclable material collection bins and disposal in authorized centres. Other components (electrical boards, remote control batteries, etc.), however, may contain polluting substances. They should therefore be removed and given to qualified service companies for proper disposal.

Prior to disposal, it is always advisable to check specific regulations in force in the place of disposal.

#### **PLEASE DISPOSE OF PROPERLY!**

All the data and information contained herein is considered subject to change at any time and at our discretion

# 8 Manufacturer's warranty



## MANUFACTURER'S DECLARATION OF CONFORMITY

Pursuant to annex II B of the Machinery Directive 98/37/EC



**CAME Cancelli Automatici S.p.A.**  
via Martiri della Libertà, 15  
31030 Dosson di Casier - Treviso - ITALY  
tel (+39) 0422 4940 - fax (+39) 0422 4941  
internet: www.came.it - e-mail: info@came.it

### IMPORTANT WARNING!

**Do not use the equipment specified here above, before completing the full installation  
In full compliance with the Machinery Directive 98/37/EC**

Declares under its own responsibility that the equipments for automatic garage doors and gates listed below:

#### AUTOMATION FOR STREET BARRIERS G4040 - G4040I

CONTAINING SOME OF THE FOLLOWING ACCESSORIES  
G03750 - G03751 - G03752 - G02040 - G04060 - G06080  
G02801 - G02802 - G02803 - G02804 - G02807 - G02808 - G02809 - G0465

... comply with the National Law related to the following European Directives and to the applicable parts of the following Standards.

98/37/CE - 98/79/CE	MACHINERY DIRECTIVE
98/336/CEE - 92/31/CEE	ELECTROMAGNETIC COMPATIBILITY DIRECTIVE
73/23/CEE - 93/68/CE	LOW VOLTAGE DIRECTIVE
89/106/CEE	CONSTRUCTION PRODUCTS DIRECTIVE

EN 13241-1	EN 12635	EN 61000-6-2
EN 12453	EN 12978	EN 61000-6-3
EN 12445	EN 60335-1	EN 60204-1

MANAGING DIRECTOR  
Mr. Andrea Menuzzo

Reference code to request a true copy of the original: **DDF B EN G001 ver.1.0**

All the data and information contained herein is considered subject to change at any time and at our discretion

ENGLISH



**CAME UNITED KINGDOM LTD**  
UNIT 3, ORCHARD BUSINESS PARK TOWN  
STREET, SANDIACRE  
NOTTINGHAM - NG10 5BP - U.K.  
Tel 0044 115 9210430  
Fax 0044 115 9210431

