

IPC-T2A30-Z

3MP IR Eyeball Network Camera



- 1/3" 3Megapixel progressive CMOS
- H.264+ & H.264 dual-stream encoding
- 20fps@3M(2048x1536) & 25/30fps@2M (1920x1080)
- DWDR, Day/Night(ICR), 3DNR, AWB, AGC, BLC
- Multiple network monitoring: Web viewer, CMS(DSS/PSS) & DMSS
- Micro SD card slot, up to 128GB
- 2.7~12mm varifocal lens
- Max IR LEDs Length 60m
- IP67, PoE



System Overview

The EZ-IP series is perfect for small to medium size applications like home/residential security, small retail shops, and other typical SMB applications. It offers a perfect alternative to migrate from analog to an IP system with its easy to use nature and cost effectiveness.

The EZ-IP series is fully in line with Dahua's quality assurance protocol. Various tests such as anti-vibration, water resistance, and aging tests are performed to ensure Dahua quality standards.

Functions

True Day/Night

A day/night mechanical IR cut filter makes this camera ideal for applications with fluctuating lighting conditions, delivering color images during the day and automatically switching to monochrome as the scene darkens

Regions of interest

Regions of Interest (ROI) is a user defined feature that allows the operator to monitor specific areas of a scene while still maintaining overall situational awareness of less important areas

Smart IR

With IR illumination, detailed images can be captured in low light or total darkness. The camera's Smart IR technology adjusts to the intensity of camera's infrared LEDs to compensate for the distance of an object. Smart IR technology prevents IR LEDs from whiting out images as they come closer to the camera. The camera's integrated infrared illumination provides high performance in extreme low-light environments up to 60m (197ft).

Image flip

Capturing unnecessary data such as surrounding hallway walls can increase storage requirements without any added value. The image flip feature allows the camera's image to be rotated in 90° increments for better video optimization.

Protection

Supporting $\pm 10\%$ input voltage tolerance, this camera suits even the most unstable conditions for outdoor applications. Its 6KV lightning rating provides protection against the camera and its structure from the effects of lightning.

Interoperability

The camera conforms to the ONVIF (Open Network Video Interface Forum) specifications, ensuring interoperability between network video products regardless of manufacturer

Smart H.264+

Delivering high quality video without straining the network, Smart H.264+ is the optimized implementation of H.264. The Smart H.264+ encoding platform includes a scene adaptive encoding strategy, dynamic GOP, dynamic ROI, flexible multi-frame reference structure and intelligent noise reduction, providing a savings of up to 70% of bandwidth and storage when compared with standard H.264.

Technical Specification

Camera

Image Sensor	1/3" 3Megapixel Progressive CMOS
Effective Pixels	2304(H) x1536(V)
RAM/ROM	128MB/16MB
Scanning System	Progressive
Minimum Illumination	0.1Lux/F1.4(Color), 0Lux/F1.4(IR on)
S/N Ratio	More than 50dB
IR Distance	Distance up to 60m(197ft)
IR On/Off Control	Auto/ Manual
IR LEDs	2

Lens

Lens Type	Motorized
Mount Type	Board-in
Focal Length	2.7mm~12mm
Max. Aperture	F1.4
Angle of View	H:92°~28°, V:42°~15°
Focus Control	Motorized
Close Focus Distance	0.3m

PTZ

Pan/Tilt Range	Pan:0° ~360° ;Tilt:0° ~78° ;Rotation:0° ~360°
----------------	---

Video

Compression	H.264+/H.264
Streaming Capability	2 Streams
Resolution	3M(2048x1536)/1080P(1920x1080)/1.3M(1280x960)/ 720P(1280x720)/D1(704x576/704x480)/CIF(352x288/352x240)
Frame Rate	3M(1~20fps) D1/CIF(1 ~ 25/30fps)
Bit Rate Control	CBR/VBR
Bit Rate	H264:24K ~ 8Mbps
Day/Night	Auto(ICR) / Color / B/W
BLC Mode	BLC / HLC / DWDR

White Balance	Auto/Natural/Street Lamp/Outdoor/Manual
Gain Control	Auto/Manual
Noise Reduction	3D DNR
Motion Detetion	Off / On (4 Zone, Rectangle)
Region of Interest	Off / On (4 Zone)
Electronic Image Stabilization(EIS)	N/A
Smart IR	Support
Digital Zoom	16x
Flip	0°/90°/180°/270°
Mirror	Off / On
Privacy Masking	Off / On (4 Area, Rectangle)

Audio

Compression	N/A
-------------	-----

Network

Ethernet	RJ-45 (10/100Base-T)
Protocol	HTTP;HTTPS;TCP;ARP;RTSP;RTP;UDP;SMTP;FTP;DHCP;DNS;DDNS;PPPOE;IPv4/v6;QoS;UPnP;NTP
Interoperability	ONVIF, PSIA, CGI
Streaming Method	Unicast / Multicast
Max. User Access	10 Users/20 Users
Edge Storage	NAS(Network Attached Storage) Local PC for instant recording Micro SD Card 128GB
Web Viewer	IE, Chrome, Firefox, Safari
Management Software	Smart PSS, DSS,Easy4ip
Smart Phone	IOS, Android

Certifications

Certifications	CE (EN 60950:2000) UL:UL60950-1 FCC: FCC Part 15 Subpart B
----------------	--

Interface

Video Interface	N/A
Audio Interface	N/A
RS485	N/A
Alarm	N/A

Electrical

Power Supply	DC12V PoE (802.3af)(Class 0)
Power Consumption	< 9.8W

Environmental

Operating Conditions	-30° C ~ +60° C (-22° F ~ +140° F) / Less than 95% RH
Storage Conditions	-30° C ~ +60° C (-22° F ~ +140° F) / Less than 95% RH
Ingress Protection	IP67
Vandal Resistance	N/A

Construction

Casing	Metal
Dimensions	Φ122mm x 104.9mm(4.8" x 4.1")
Net Weight	0.59Kg(1.30lb)
Gross Weight	0.71Kg(1.57lb)

Ordering Information

Type	Part Number	Description
3MP Camera	IPC-T2A30P-Z	3MP IR Eyeball Network Camera, PAL
	IPC-T2A30N-Z	3MP IR Eyeball Network Camera, NTSC
	IPC-T2A30P-Z	3MP IR Eyeball Network Camera, PAL
	IPC-T2A30N-Z	3MP IR Eyeball Network Camera, NTSC
Accessories (optional)	PFA137	Junction box
	PFB203W	Wall mount
	PFA152	Pole mount

Accessories

Optional:

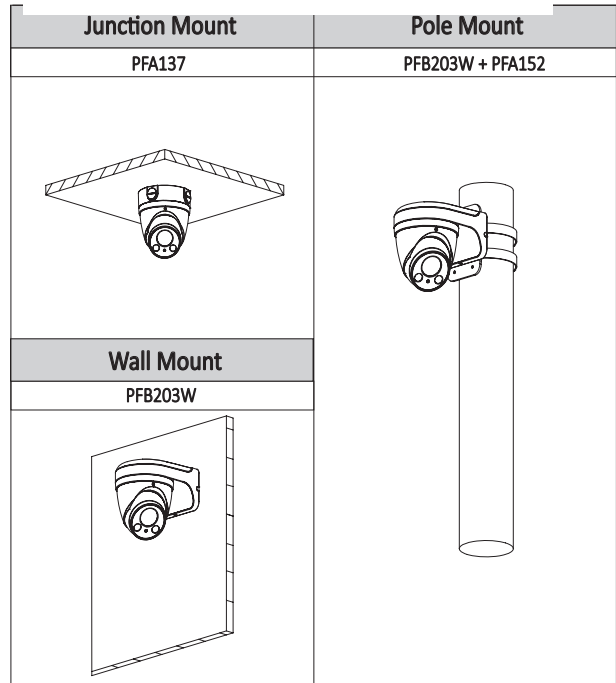
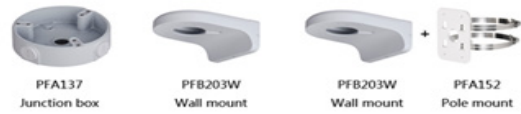

Dimensions (mm/inch)

