

SmartLoop/NET



EN 54-2
EN 54-4
EN 54-21

0051
0051-CPR-1415
0051-CPR-1416
0051-CPR-1417
0051-CPR-1418
0051-CPR-1419
0051-CPR-1420

BOARD FOR THE CONNECTION OF SMARTLOOP CONTROL PANELS IN A HORNET NETWORK

SMARTLOOP

The SmartLoop/NET board allows up to 30 SmartLoop control panels to be configured in a **HorNet** network.

The control panels in the network are capable of sharing information and therefore operate as a single system.

The HorNet network (token ring) is created by means of shielded twisted pair cable (3 pole). The maximum cable length of 2000 metres (allowed between each control panel) provides a highly fault-tolerant network.

This type of network is capable of operating even in the event of faults along the cable.

A supplementary 2 pole STP cable (5 poles in all) will allow you to create a protection ring which can pass alarm conditions, generated by a control panel with a microprocessor fault, through the ring thus ensuring maximum reliability (**Emergency54** technology).



MAIN FEATURES

- Supported by SmartLoop control panels
- Allows the connection of up to 30 control panels in a network
- 1 board for each control panel
- Equipped with 2 communication ports for the creation of a token ring
- Each communication port is uncoupled to avoid earthing rings
- Communication based on RS485 protocol

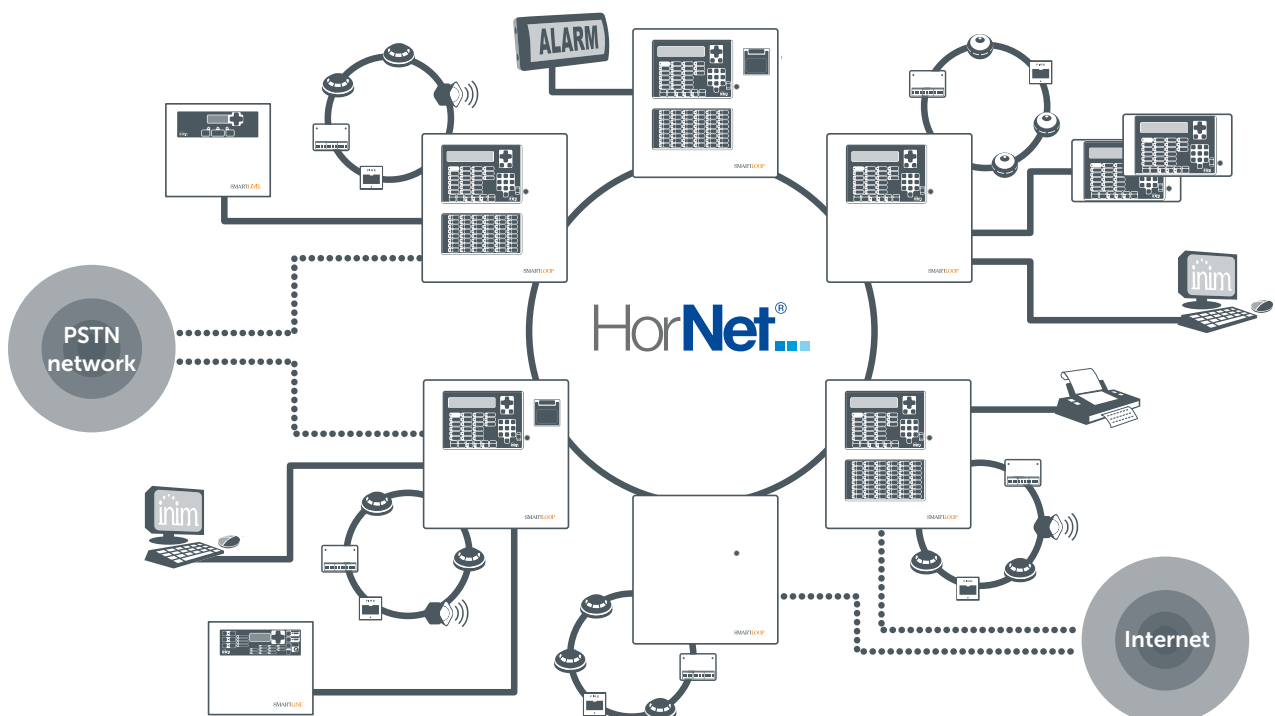

INSTALLATION

The board comes with supports which screw into the motherboard.
The board plugs directly into the motherboard.

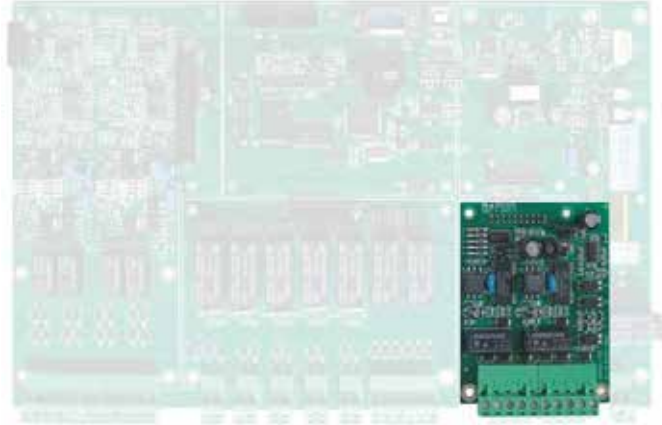

CONNECTIONS

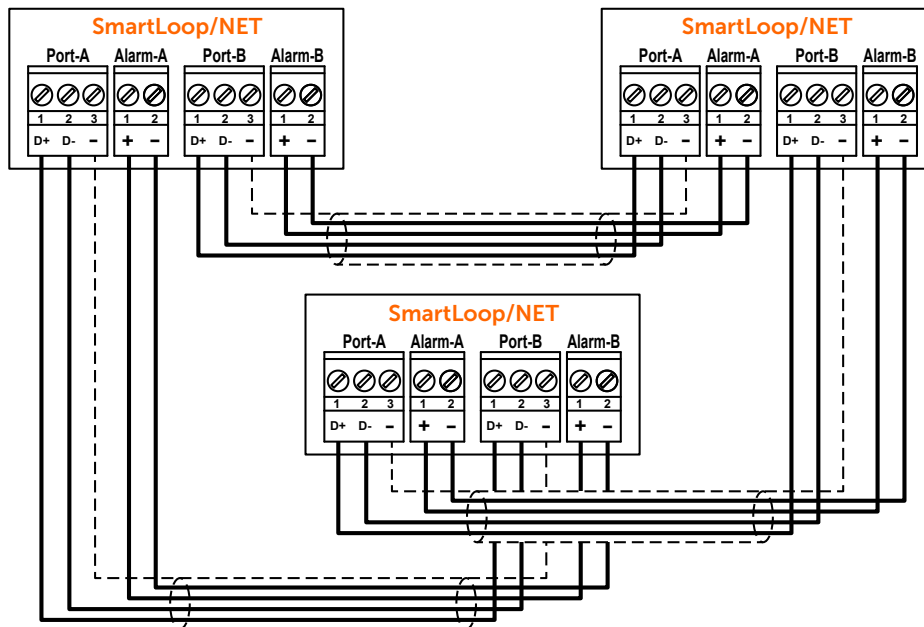

ORDER CODES

- SmartLoop/2080-P:** control panel with 2 loops expandable to 8, equipped with command keypad, display, status LEDs and housing for SmartLoop/PRN printer (accessory item)
- SmartLoop/2080-G:** control panel with 2 loops expandable to 8, equipped with command keypad and display
- SmartLoop/2080-S:** control panel with 2 loops expandable to 8, with unequipped flush front
- SmartLoop/1010-P:** control panel with 1 loop, non-expandable, equipped with command keypad, display, status LEDs and housing for SmartLoop/PRN printer (accessory item)
- SmartLoop/1010-G:** control panel with 1 loop, non-expandable, equipped with command keypad and display
- SmartLoop/1010-S:** control panel with 1 loop, non-expandable, with unequipped flush front
- SmartLoop/NET:** board for the connection of SmartLoop control panels in a HorNet network