

Nice

HYKE

HK7024

HK7224

HK7024HS

HK7224HS



Swing gate opener

EN - Instructions and warnings for installation and use

Nice

CONTENTS

1	GENERAL SAFETY WARNINGS AND PRECAUTIONS	2
1.1	General warnings	2
1.2	Installation warnings	3
2	PRODUCT DESCRIPTION AND INTENDED USE	3
2.1	List of constituent parts	3
3	INSTALLATION	4
3.1	Pre-installation checks	4
3.2	Product usage limits	4
3.2.1	Product durability	5
3.3	Product identification and overall dimensions	5
3.4	Pre-installation works	6
3.5	Installing the gearmotor	6
3.5.1	Determining the length of the gearmotor arm	7
3.5.2	Installing the gearmotor with FULL-LENGTH ARM	7
3.5.3	Installing the gearmotor with REDUCED-LENGTH ARM	9
3.6	Adjusting the mechanical limit switches	12
3.7	Manually unlocking and locking the gearmotor	12
4	ELECTRICAL CONNECTIONS	13
4.1	Preliminary checks	13
4.2	Wiring diagram and description of connections	15
4.2.1	Wiring diagram	15
4.2.2	Description of connections	15
5	FINAL CHECKS AND START-UP	16
5.1	Power supply connection	16
5.2	Device learning	16
5.3	Motor selector	17
5.4	Learning of the mechanical stop positions	17
5.4.1	Learning in automatic mode	18
5.4.2	Learning in manual mode	18
5.4.3	Learning in mixed mode	19
5.5	Checking the gate movement	19
5.6	Connecting other devices to the control unit	20
6	TESTING AND COMMISSIONING	20
6.1	Testing	20
6.2	Commissioning	20
7	PROGRAMMING	21
7.2	Level 1 programming (ON-OFF)	21
7.2.1	Level 1 programming procedure	21
7.1	Using the programming buttons	21
7.3	Level 2 programming (adjustable parameters)	22
7.3.1	Level 2 programming procedure	22
7.4	Special functions	24
7.4.1	"Move anyway" function	24
7.4.2	"Maintenance notice" function	24
7.5	Memory deletion	24
8	TROUBLESHOOTING GUIDE	25
8.1	Signalling through warning light	25
8.2	Signals on the control unit	26
8.3	Anomaly log	27
9.1	Adding or removing devices	27
9.1.1	BlueBUS	27
9.1.2	STOP input	28
9.1.3	Photocells	28
9.1.4	Learning of other devices	28
9.2	Connecting an SM-type radio receiver	29
9.3	Connecting and installing the back-up battery	30
9.4	Connecting the external unlocking system Kio	31
9.5	Connecting the Oview programmer	32
9.6	Connecting the Solemyo solar energy system	33
9	PRODUCT MAINTENANCE	34
10	PRODUCT DISPOSAL	34
11	TECHNICAL SPECIFICATIONS	35
12	CONFORMITY	37
INSTRUCTIONS AND WARNINGS FOR THE USER		39

1 GENERAL SAFETY WARNINGS AND PRECAUTIONS

1.1 GENERAL WARNINGS



WARNING! Important safety instructions. Observe all the instructions as improper installation may cause serious damages.



WARNING! Important safety instructions. It is important to comply with these instructions to ensure personal safety. Store these instructions carefully.



According to the latest European legislation, an automated device must be constructed in conformity to the harmonised rules specified in the current Machinery Directive, which allow for declaring the presumed conformity of the automation. Consequently, all the operations for connecting the product to the mains electricity, its commissioning and maintenance must be carried out exclusively by a qualified and expert technician.



In order to avoid any danger from inadvertent resetting of the thermal cut-off device, this appliance must not be powered through an external switching device, such as a timer, or connected to a supply that is regularly powered or switched off by the circuit.

WARNING! Please abide by the following warnings:

- Before commencing the installation, check the "Product technical specifications", in particular whether this product is suitable for automating your guided part. Should it not be suitable, do NOT proceed with the installation.
- The product cannot be used before it has been commissioned as specified in the "Testing and commissioning" chapter.
- Before proceeding with the product's installation, check that all the materials are in good working order and suited to the intended applications.
- The product is not intended for use by persons (including children) with reduced physical, sensory or mental capacities, nor by anyone lacking sufficient experience or familiarity with the product.
- Children must not play with the appliance.
- Do not allow children to play with the product's control devices. Keep the remote controls out of reach of children.
- The system's power supply network must include a disconnection device (not supplied) with a contact opening gap permitting complete disconnection under the conditions envisaged by Overvoltage Category III.
- During the installation process, handle the product with care by avoiding crushing, impacts, falls or contact with liquids of any kind. Do not place the product near sources of heat nor expose it to open flames. All these actions can damage the product and cause it to malfunction, or lead to dangerous situations. Should this occur, immediately suspend the installation process and contact the Technical Assistance Service.

- The manufacturer declines all liability for damages to property, objects or people resulting from failure to observe the assembly instructions. In such cases, the warranty for material defects shall not apply.
- The weighted sound pressure level of the emission A is lower than 70 dB(A).
- Cleaning and maintenance reserved for the user must not be carried out by unsupervised children.
- Before intervening on the system (maintenance, cleaning), always disconnect the product from the mains power supply and from any batteries.
- Inspect the system frequently, in particular the cables, springs and supports to detect any imbalances and signs of wear or damage. Do not use the product if it needs to be repaired or adjusted, because defective installation or incorrect balancing of the automation can lead to injuries.
- The packing materials of the product must be disposed of in compliance with local regulations.
- Keep persons away from the gate when it is manoeuvred using the control elements.
- When operating the gate, keep an eye on the automated mechanism and keep all bystanders at a safe distance until the movement has been completed.
- Do not operate the product if anyone is working nearby; disconnect its power supply before permitting such work to be done.

1.2 INSTALLATION WARNINGS

- Prior to installing the drive motor, check that all mechanical components are in good working order and properly balanced, and that the automation can be manoeuvred correctly.
- If the gate being automated has a pedestrian gate, the system must be equipped with a control device that inhibits the motor's operation when the pedestrian gate is open.
- Make sure that the control elements are kept far from moving parts but nonetheless directly within sight. Unless a selector is used, the control elements must be installed at least 1.5 m above the ground and must not be accessible.
- If the opening movement is controlled by a fire-sensing system, make sure that any windows larger than 200 mm are closed using the control elements.
- Prevent and avoid any form of entrapment between the moving and fixed parts during the manoeuvres.
- Permanently affix the label concerning the manual manoeuvre near its actuating element.
- After installing the drive motor, make sure that the mechanism, protective system and all manual manoeuvres function properly.

2

PRODUCT DESCRIPTION AND INTENDED USE

HYKE is a series of gearmotors with articulated arm and external assembly, which can be used to automate residential or industrial swing gates or doors. They are equipped with a sturdy anti-shear aluminium arm and are ideal for intensive use. The main part of the automation consists of one or more electromechanical gearmotors (depending on the number of leaves to be automated), each equipped with a direct-current motor and a gear reducer with spur gears.

The **HK7024** gearmotor is equipped with a control unit that manages its operation.

The control unit is configured for being connected to the various devices belonging to the Opera System, Bluebus system and the Solemyo solar power system.

The control unit can also house a back-up battery (model PS124, optional accessory) which, in case of a blackout, allows the automation to carry out certain manoeuvres. In the event of power outage, it is still possible to move the gate leaf by unlocking the gearmotor with the appropriate key (see the "**Manually unlocking and locking the gearmotor**" paragraph).

The automation allows for installing various accessories to increase its functions and improve safety.



Any use of the product other than the intended use described is not allowed!

2.1 LIST OF CONSTITUENT PARTS

"**Figure 1**" shows the main parts making up the **HK7024** gearmotor.

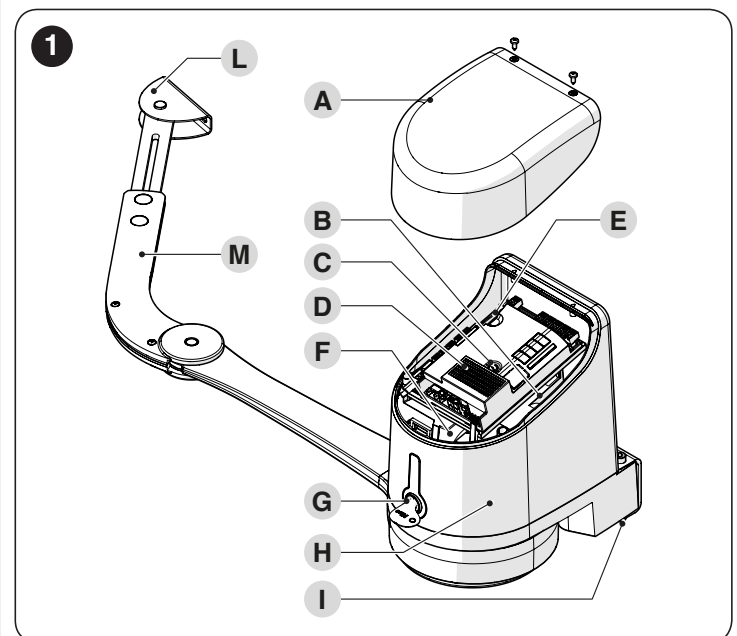

- A** Cover
- B** Back-up battery (accessory)
- C** Fuse
- D** Electronic control and command unit (present only on **HK7024** and **HK7024HS**)
- E** OXI receiver
- F** Power supply connector
- G** Locking/unlocking key
- H** Gearmotor
- I** Gearmotor fixing bracket
- L** Arm fixing bracket
- M** Arm

3 INSTALLATION

3.1 PRE-INSTALLATION CHECKS

⚠ The installation must be carried out by qualified personnel in compliance with the current legislation, standards and regulations, and with the instructions provided in this manual.

Before proceeding with the product's installation, it is necessary to:

- check the integrity of the supply
- check that all the materials are in good working order and suited to the intended use
- make sure that the structure of the gate is suitable for being automated
- make sure that the weight and dimensions of the gate leaf fall within the operating limits specified in the "**Product usage limits**" paragraph
- check that the installation location is compatible with the overall clearance of the product (see "**Figure 5**")
- make sure that there is enough space in the installation location for the gearmotor's arm to rotate fully (see "**Figure 2**")

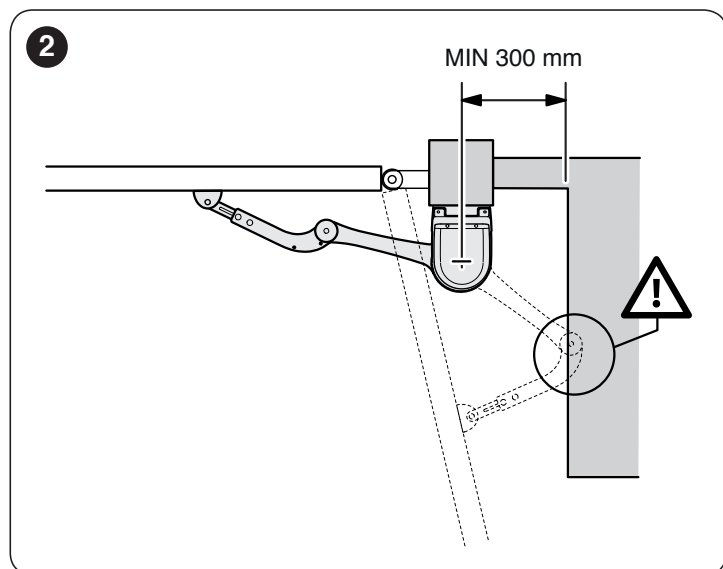

- verify that there are no points of greater friction during the opening and closing movements along the entire gate path
- verify that the overrun mechanical stops are sturdy enough and that they do not deform even if the leaf should strike them forcefully
- verify that the gate leaf is well balanced: it must not move by itself when left in any position
- make sure that the installation area is not subject to flooding; if necessary, the product must be installed appropriately raised above ground level
- verify that the area where the gearmotor is installed allows for unlocking the latter and manoeuvring easily and safely
- verify that the mounting positions of the various devices are protected against impacts and that the mounting surfaces are sufficiently sturdy
- prevent any parts of the automation from being immersed in water or other liquids

- keep the product away from heat sources and open flames and acid, saline or potentially explosive atmospheres; these may damage the product and cause malfunctions or dangerous situations
- if there is an access door in the gate, or within its range of movement, make sure that it does not obstruct the gate's normal path; install an appropriate interlock system if necessary
- connect the control unit to an electricity supply line equipped with a safety earthing system
- connect the gate to the earthing device in accordance with the current legislation
- include a device on the electric power line ensuring complete disconnection of the automation from the grid. The disconnection device must have contacts with a sufficient gap to ensure complete disconnection, under the Category III overvoltage conditions, in accordance with the installation instructions. Should it be necessary, this device guarantees fast and safe disconnection from the power supply; it must therefore be positioned in view of the automation. If placed in a non-visible location, it must have a system that blocks any accidental or unauthorised reconnection of the power supply, in order to prevent dangerous situations. The disconnection device is not supplied with the product.

3.2 PRODUCT USAGE LIMITS

Carry out the following checks before installing the gearmotor:

- check that the leaf to be automated falls within the specified values (see "**Figure 3**")
- maximum width of the leaf: 3,5 m (with weight up to 200 kg)
- maximum weight of the leaf: 330 kg (with width up to 1,8 m)
- verify the limits for the values shown in the "**TECHNICAL SPECIFICATIONS**" chapter
- minimum width of the space reserved for the gearmotor's installation: 210 mm
- the arm's fixing bracket must be attached to a sturdy point of the leaf (for example, the frame), to guarantee solid and safe anchoring.

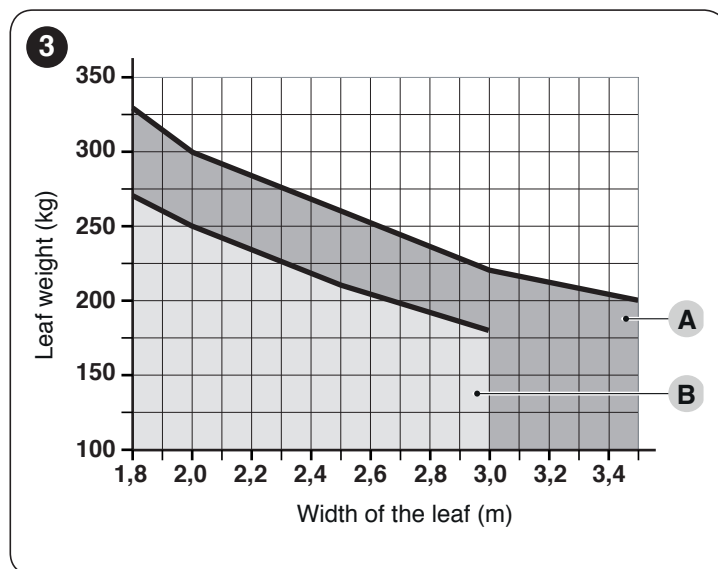

- A** For arm with FULL length
- B** For arm with REDUCED length

3.2.1 Product durability

The product's durability is its average economic life value and is strongly influenced by the degree of severity of the manoeuvres: in other words, the sum of all factors that contribute to product wear.

To estimate the durability of your automated device, proceed as follows:

1. add the values of the items in "**Table 1**" relative to the system's conditions
2. in the graph shown in "**Figure 4**", from the value obtained above, trace a vertical line until it intersects the curve; from this point trace a horizontal line until it intersects the line of the "manoeuvre cycles". The value obtained is the estimated lifetime of your product.

The durability values shown in the graph can only be obtained if the maintenance schedule is strictly observed – see the "**PRODUCT MAINTENANCE**" chapter. The durability is estimated on the basis of the design calculations and the results of tests effected on prototypes. Being an estimate, therefore, it offers no explicit guarantee of the product's actual useful life.

Example of lifetime calculation: automation of a gate with a 2,8 m-long leaf weighing 230 kg, for example with a solid leaf.

"**Table 1**" shows the "severity indices" for this type of installation: 20% ("Door length"), 20% ("Door weight") and 15% ("Solid leaf"). These indicators must be added together to obtain the overall severity index, which in this case is 55%. With the value identified (55%), look at the horizontal axis of the graph ("severity index") and identify the value corresponding to the number of "manoeuvre cycles" that the product can perform throughout its lifetime – roughly 220.000 cycles.

Table 1

PRODUCT DURABILITY		Severity index	
		arm with FULL length	arm with REDUCED length
Leaf length	< 1,8 m	0%	15%
	1,8 - 2,5 m	15%	20%
	2,5 - 3,0 m	20%	30%
	3,0 - 3,5 m	30%	-
Leaf weight	< 200 kg	0%	30%
	200 - 250 kg	20%	40%
	> 250 kg	30%	-
Ambient temperature greater than 40°C or below 0°C, or humidity greater than 80%		20%	20%
Solid leaf		15%	20%
Installation in windy areas		15%	20%

Note The data refers to a properly balanced sectional door in good working order.

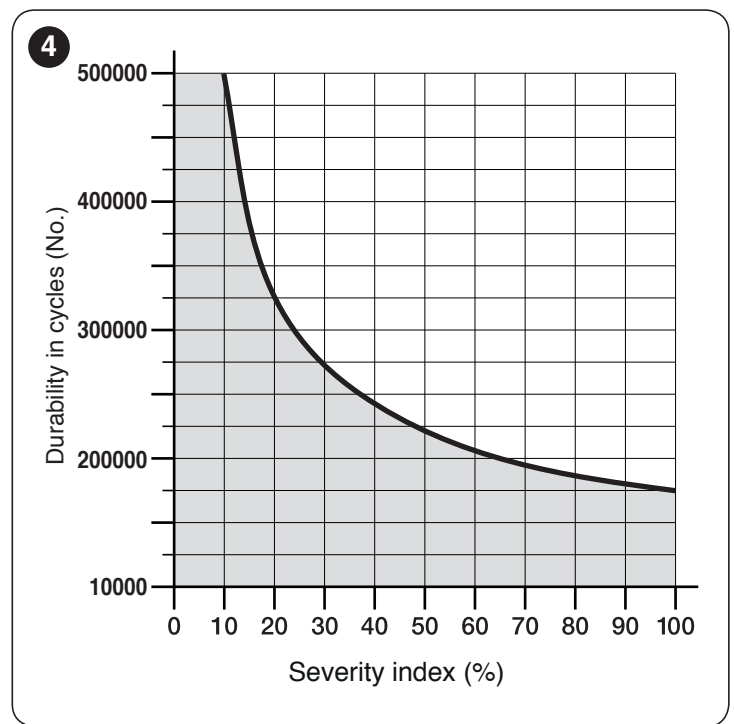

3.3 PRODUCT IDENTIFICATION AND OVERALL DIMENSIONS

The overall dimensions and the label (**A**), which allows for identifying the product, are shown in "**Figure 5**".

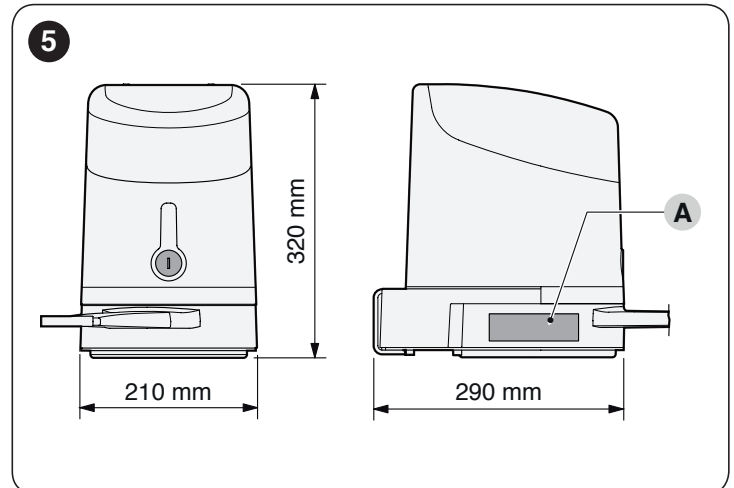

3.4 PRE-INSTALLATION WORKS

The figure shows an example of an automation system, constructed using **Nice** components.

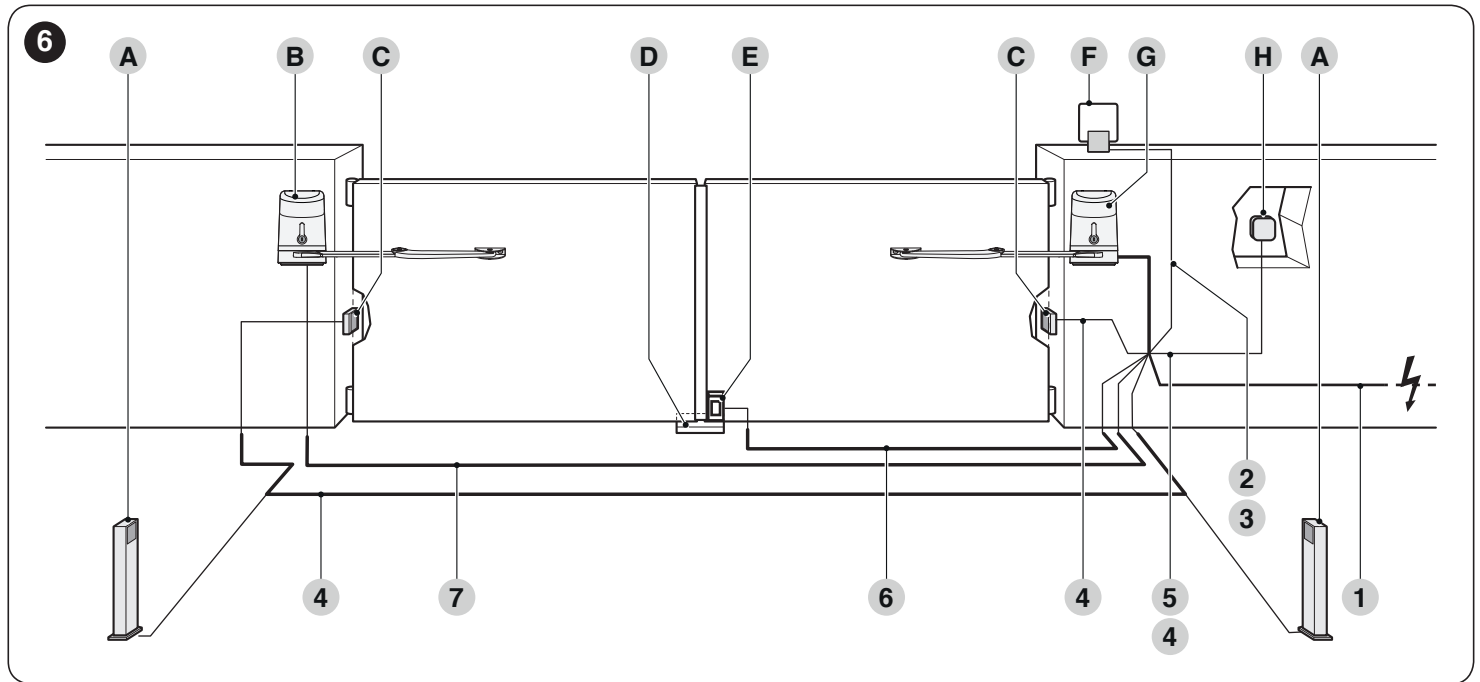

- A** Photocells on column
- B** Gearmotor without control unit (models **HK7224** and **HK7224HS**)
- C** Photocells (model EPM)
- D** Mechanical stop at closed position
- E** Electric lock
- F** Warning light MLBT
- G** Gearmotor with control unit (models **HK7024** and **HK7024HS**)
- H** Digital keypad (model EDSB) - Transponder reader (model ETPB) - Key selector EKSU)

These above-mentioned components are positioned according to a typical standard layout. Using the layout in “**Figure 6**” as a reference, define the approximate position in which each component of the system will be installed.

Table 2

TECHNICAL SPECIFICATIONS OF ELECTRICAL CABLES	
Identification no.	Cable characteristics
1	CONTROL UNIT POWER SUPPLY cable 1 cable 3 x 1.5 mm ² Maximum length 30 m [note 1]
2	WARNING LIGHT cable 1 cable 2 x 0.5 mm ² Maximum length 20 m
3	ANTENNA cable 1 x RG58-type shielded cable Maximum length 20 m; recommended < 5 m
4	BLUEBUS DEVICES cable 1 cable 2 x 0.5 mm ² Maximum length 20 m [note 2]
5	KEY SELECTOR cable 2 cables 2 x 0.5 mm ² [note 3] Maximum length 50 m
6	ELECTRIC LOCK cable 1 cable 2 x 1 mm ² Maximum length 6 m
7	GEARMOTOR POWER SUPPLY cable 1 cable 3 x 1.5 mm ² Maximum length 10 m [note 4] ENCODER CONNECTION cable 1 cable 2 x 1 mm ² Maximum length 10 m [note 4]

Note 1 If the power supply cable is longer than 30 m, a cable with larger cross-sectional area (3 x 2.5 mm²) must be used and a safety earthing system must be installed near the automation.

Note 2 If the BlueBus cable is longer than 20 m, up to maximum 40 m, it is necessary to use a cable with a greater cross-sectional area (2 x 1 mm²).

Note 3 These two cables can be replaced by a single 4 x 0.5 mm² cable.

Note 4 This cable can be replaced by a single 5 x 1.5 mm² cable.

! Before proceeding with the installation, prepare the required electrical cables by referring to “**Figure 6**” and to that stated in the “**TECHNICAL SPECIFICATIONS**” chapter.

! The cables used must be suited to the type of environment of the installation site.

! When laying the pipes for routing the electrical cables, take into account that any water deposits in the junction boxes may cause the connection pipes to form condensate inside the control unit, thus damaging the electronic circuits.

3.5 INSTALLING THE GEARMOTOR

! Incorrect installation may cause serious physical injury to the person working on the system or to its future users.

Before starting to assemble the automation, complete the preliminary checks described in the “**Pre-installation checks**” and “**Product usage limits**” paragraphs.

Before starting the installation, it is necessary to determine the length of the gearmotor arm – refer to the paragraph “**Determining the length of the gearmotor arm**”.

3.5.1 Determining the length of the gearmotor arm

Assemble the components making up the motor arm:

1. attach the curved arm (A) to the straight arm (B) using the pin (C) and retaining ring (D). likewise, attach the fixing bracket for the gate leaf (E) to the curved arm (A)

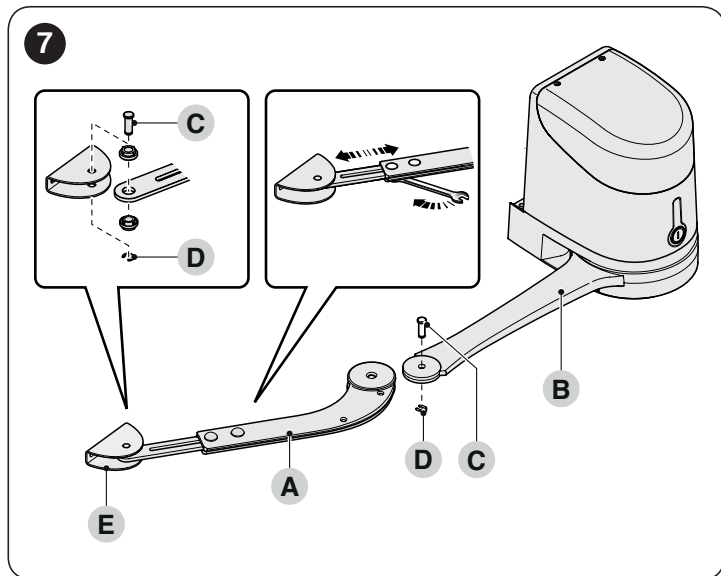

2. to define the position of the gearmotor VERTICALLY, draw a horizontal line on the pillar at the same height at which the arm's fixing bracket will be on the leaf, after the installation
3. define the position of the gearmotor HORIZONTALLY [level A].

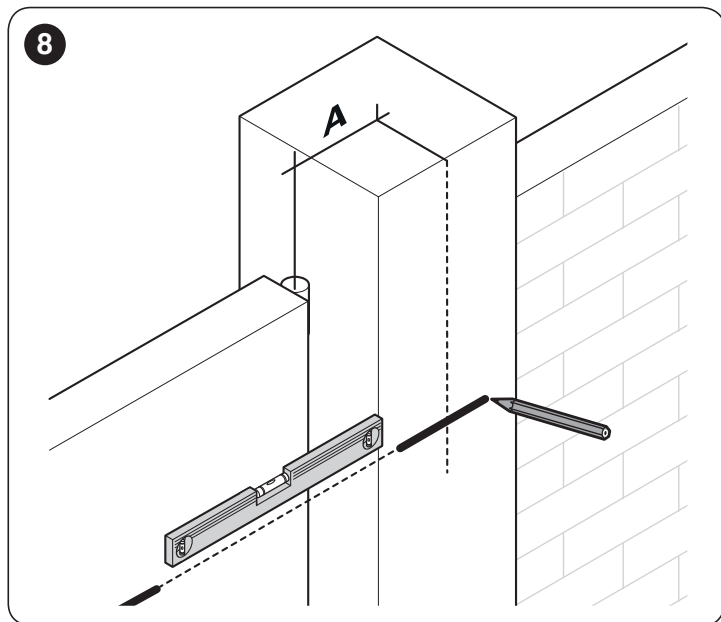

! If there is a fixed obstacle (wall, tree, etc.) near the installation area, measure distance E then proceed as follows:

- If distance (E) is equal to or above 650 mm, consult the paragraph “**Installing the gearmotor with FULL-LENGTH ARM**”
- If distance (E) is between 300 mm (minimum) and 650 mm (maximum), consult the paragraph “**Installing the gearmotor with REDUCED-LENGTH ARM**”.

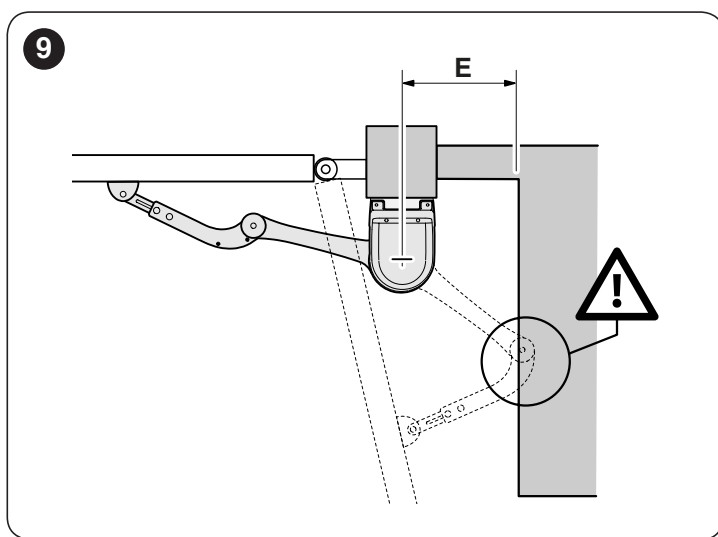

3.5.2 Installing the gearmotor with FULL-LENGTH ARM

To install **HYKE**:

1. measure the distance (B)

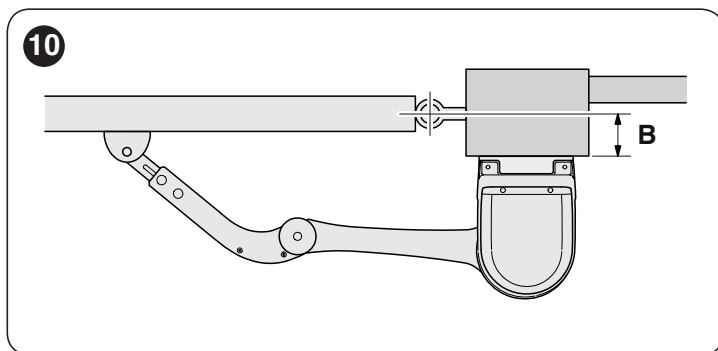

2. move the leaf to the desired maximum opening position (maximum 110°) and check the resulting opening angle
3. mark the resulting distance (B) on the graph and, from this point, draw a horizontal line intersecting the area that includes the value of the measured opening angle
4. in the points of intersection between the horizontal line and the area, draw a few vertical lines to determine the values that can be used for level (A); choose in this range a value for level (A). For example: if (B) is 200 mm and the desired angle is 110°, level (A) will be between 300 mm and 345 mm

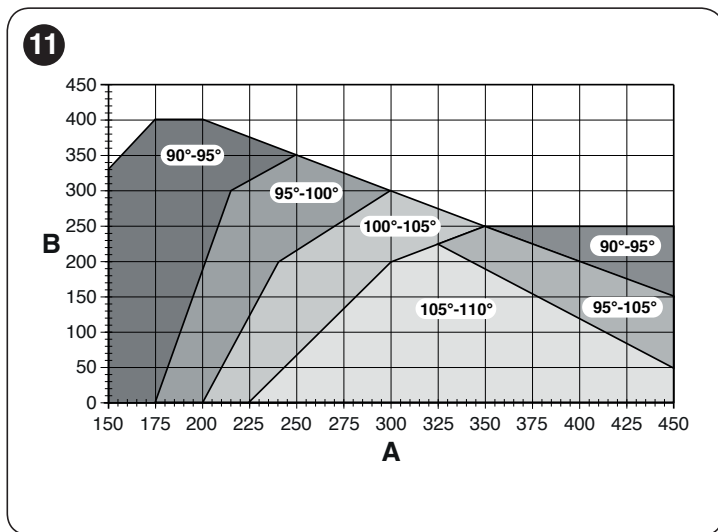

5. use the fixing bracket (C), in the horizontal position, as a template to determine the position of the four fixing holes

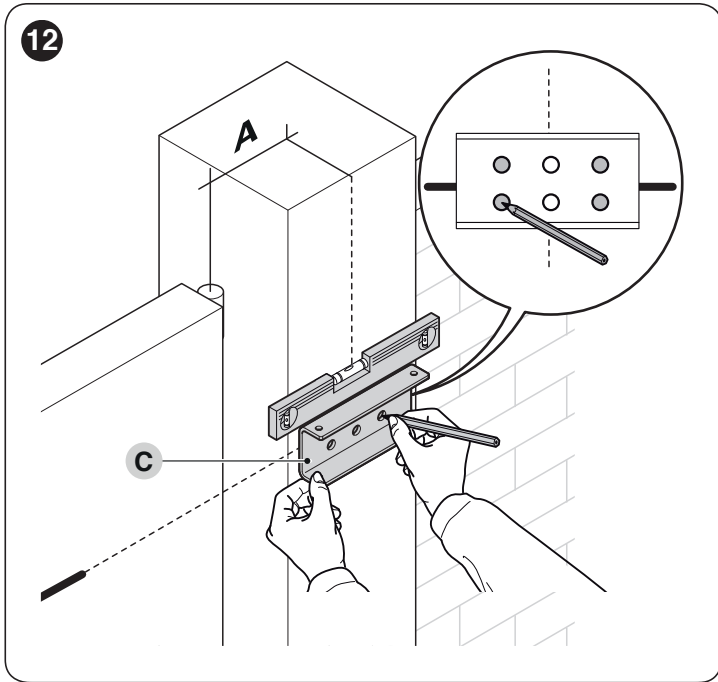

6. drill the bracket in the marked positions

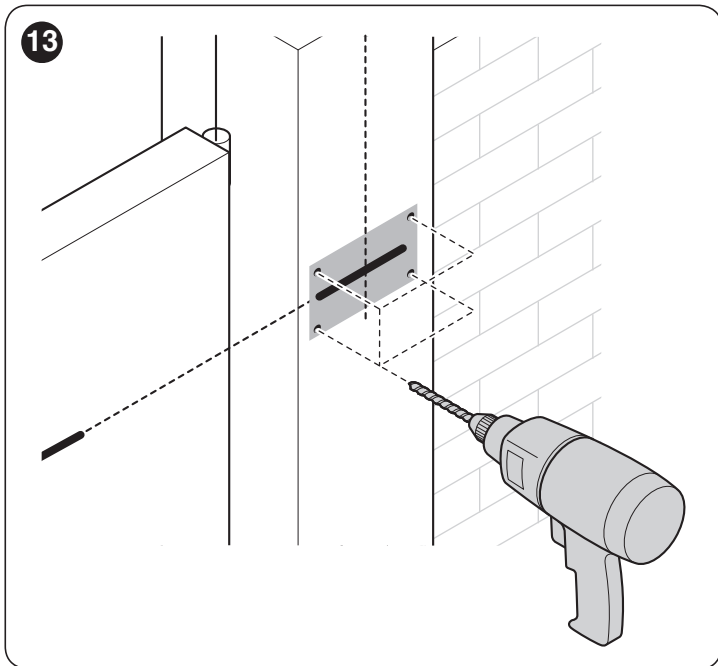

7. attach the fixing bracket (C) of the gearmotor to the wall using adequate wall plugs, screws and washers (not supplied)

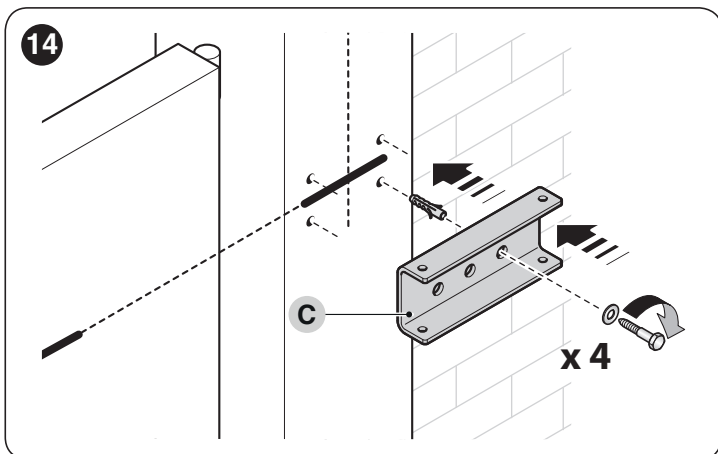

8. attach the gearmotor to the bracket using the two screws (D) provided

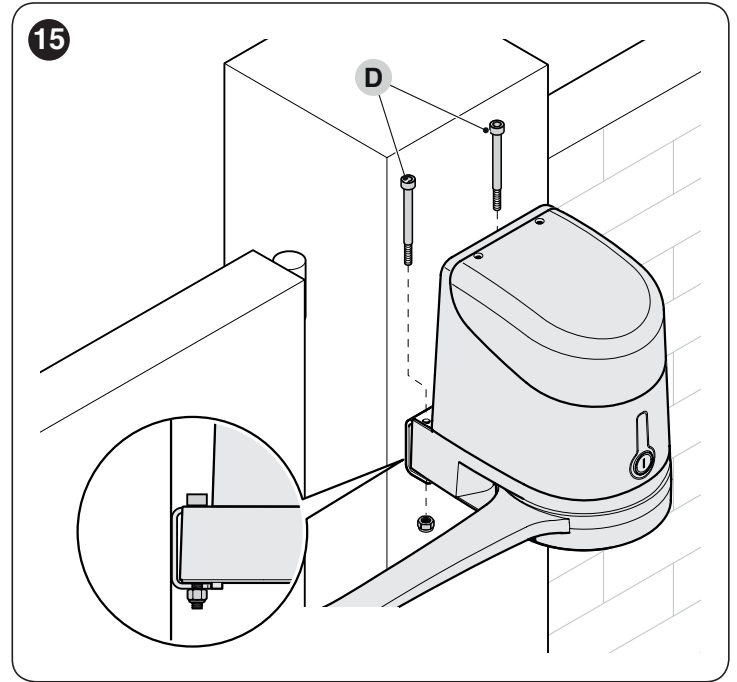

9. unlock the gearmotor manually (see paragraph "**Manually unlocking and locking the gearmotor**")
10. decide where to attach the bracket to the gate leaf, by extending the gearmotor arms as far as possible



It is important to position the bracket at the farthest point with respect to the position of the gearmotor. Make sure that the arm stops at its limit switch.

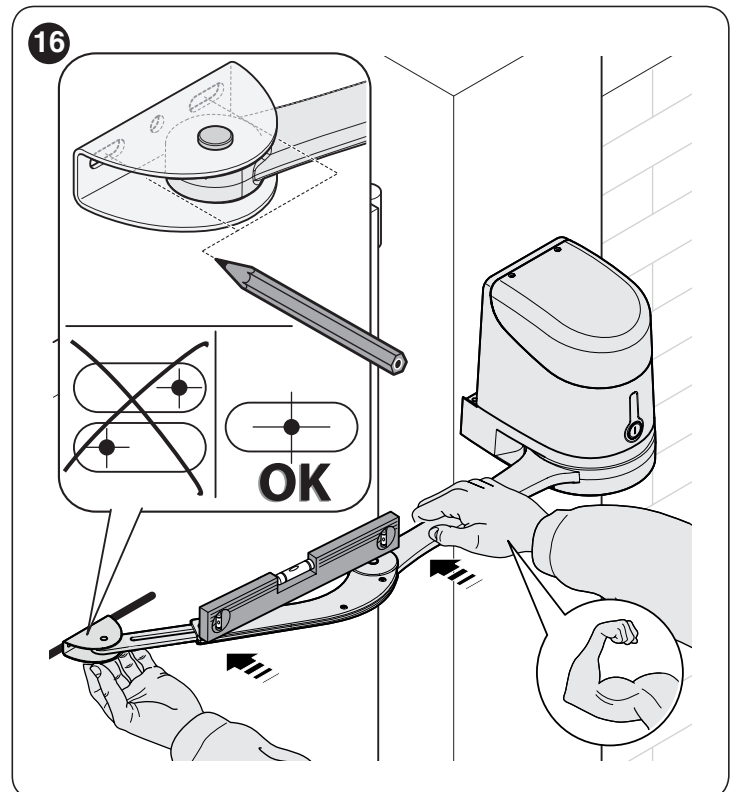

11. drill the leaf
12. separate the fixing bracket from the curved arm by removing the retaining ring and the relative pin

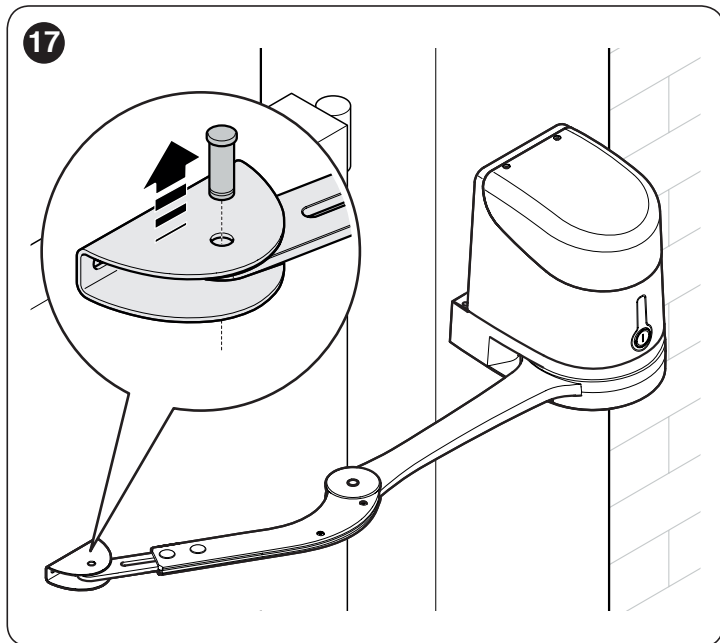

13. fasten the bracket to the gate leaf in the horizontal position, using adequate screws (not supplied)

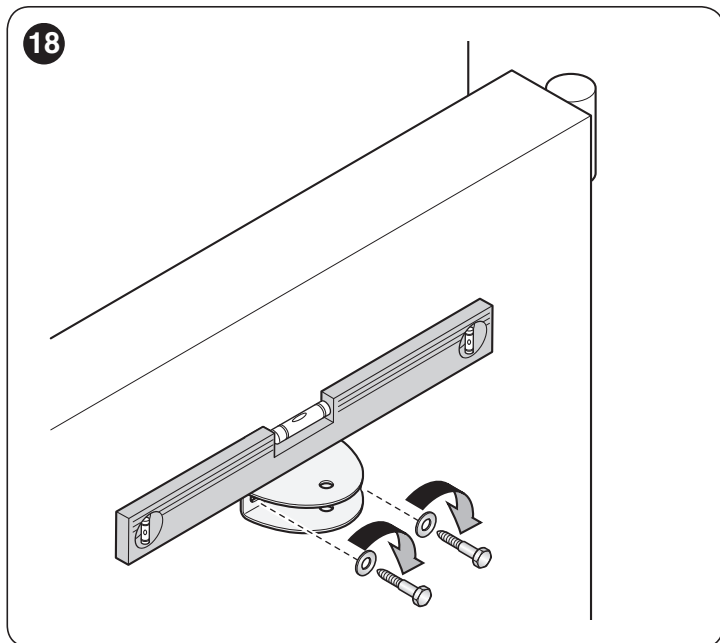

14. fasten the arm to the bracket again using the pin and retaining ring just removed
15. before locking the gearmotor, adjust the limit switches (see paragraph "**Adjusting the mechanical limit switches**")
16. manually bring the gate leaf to roughly midway along its path and lock the gearmotor as explained in the paragraph "**Manually unlocking and locking the gearmotor**". Then manually move the gate leaf by a few centimetres in the opening direction

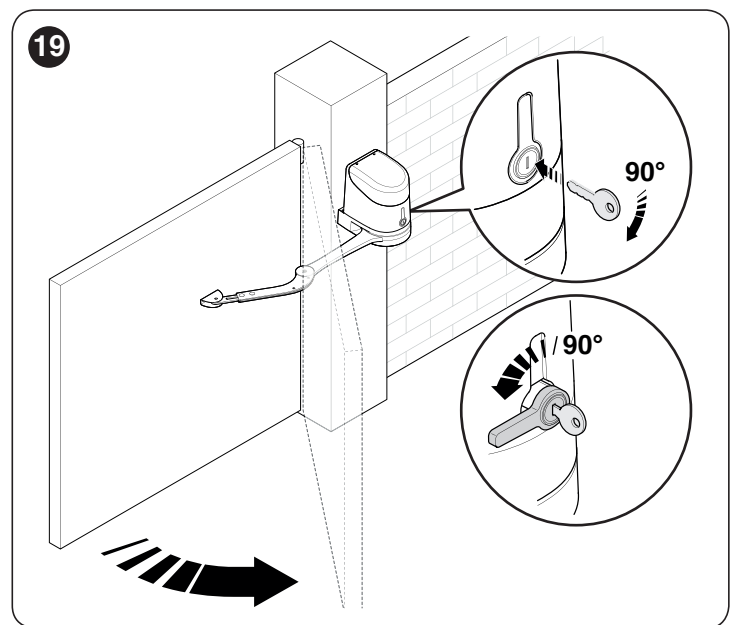

17. if the gate to be automated has two leaves, repeat all the operations described above to install the other gearmotor.

3.5.3 Installing the gearmotor with REDUCED-LENGTH ARM

 **With this configuration, the maximum allowed opening angle for the leaf is 90°.**

To install **HYKE**:

1. measure the distance (**B**)

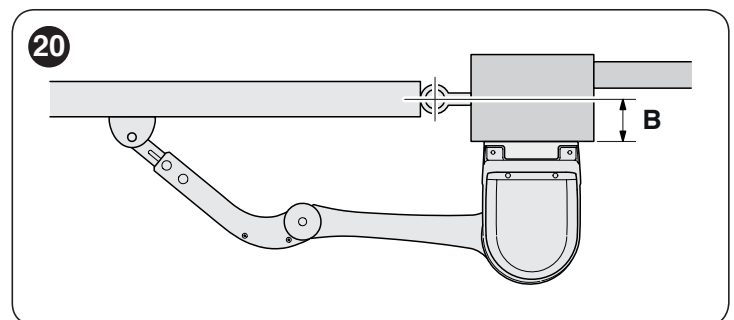

2. mark the resulting distance (**B**) on the graph and, from this point, draw a horizontal line intersecting the area between 90° and 95°
3. in the points of intersection between the horizontal line and the area, draw a few vertical lines to determine the values that can be used for level (**A**); choose in this range a value for level (**A**). For example: if (**B**) is 200 mm and the desired angle is 95°, level (**A**) will be between 400 mm and 450 mm

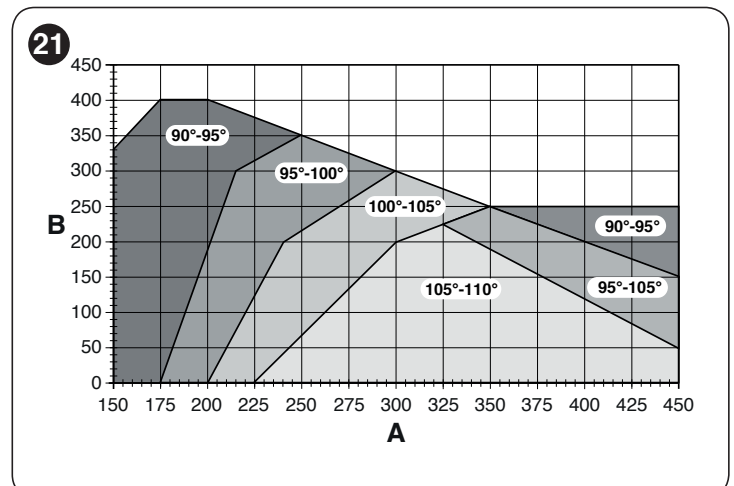

4. use the fixing bracket (C), in the horizontal position, as a template to determine the position of the four fixing holes

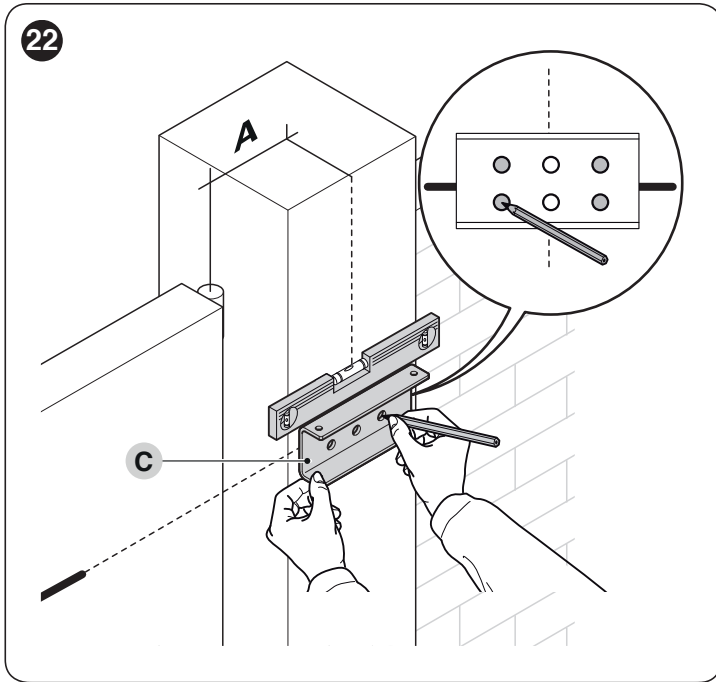

5. drill the bracket in the marked positions

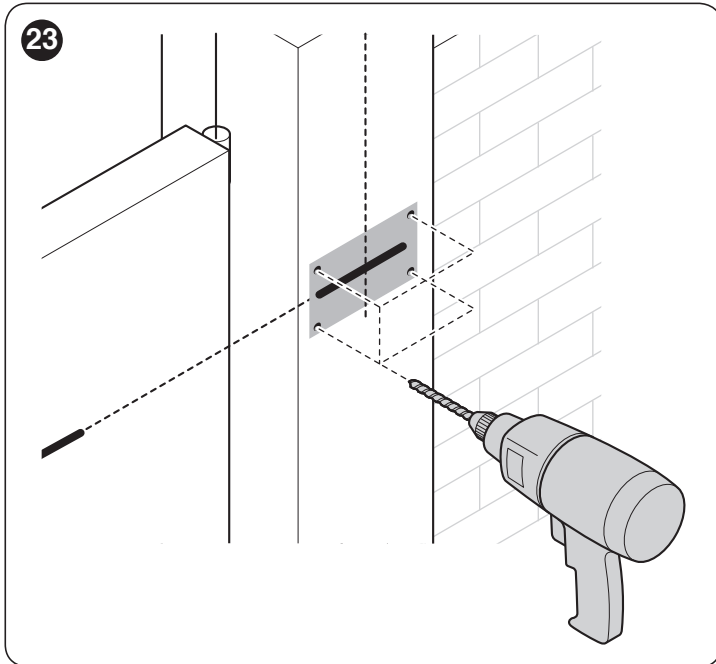

6. attach the fixing bracket (C) of the gearmotor to the wall using adequate wall plugs, screws and washers (not supplied)

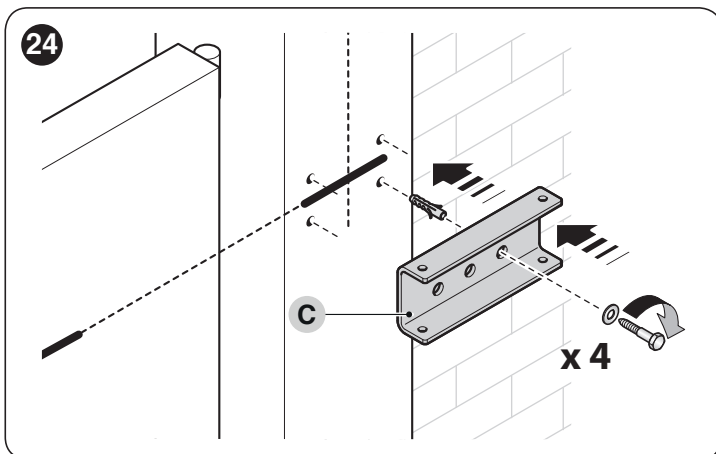

7. attach the gearmotor to the bracket using the two screws (D) provided

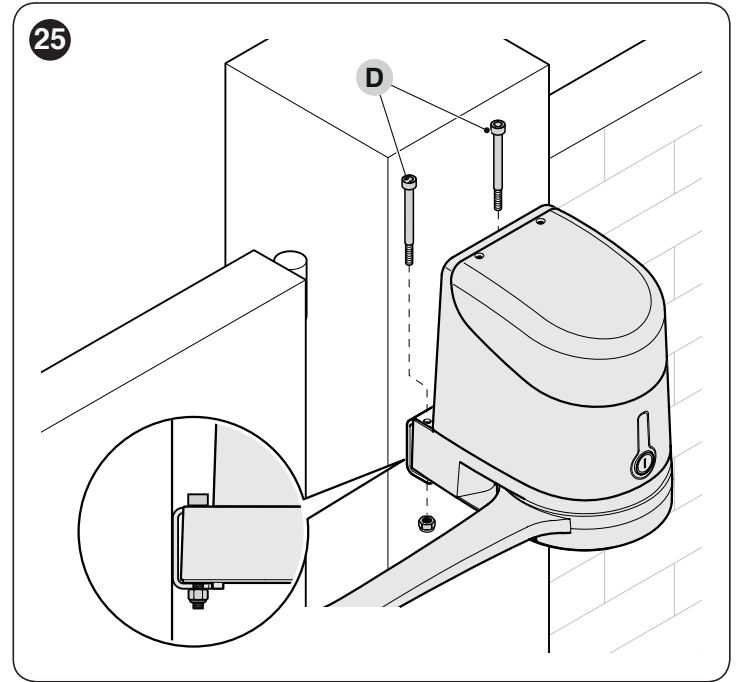

8. unlock the gearmotor manually (see paragraph "Manually unlocking and locking the gearmotor")
 9. draw the arm towards the leaf and place the fixing bracket on the latter

 Push the curved arm against the leaf using your hands, until the arm locks (maximum opening).

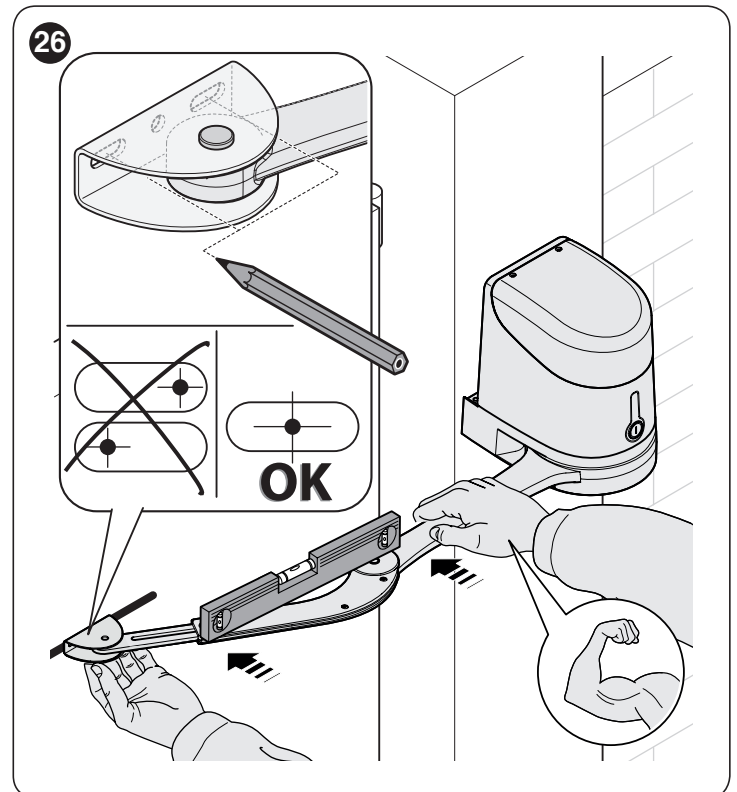

10. while keeping the bracket against the leaf with one hand, move the leaf to the maximum opening position and check that the arm does not collide with any obstacles

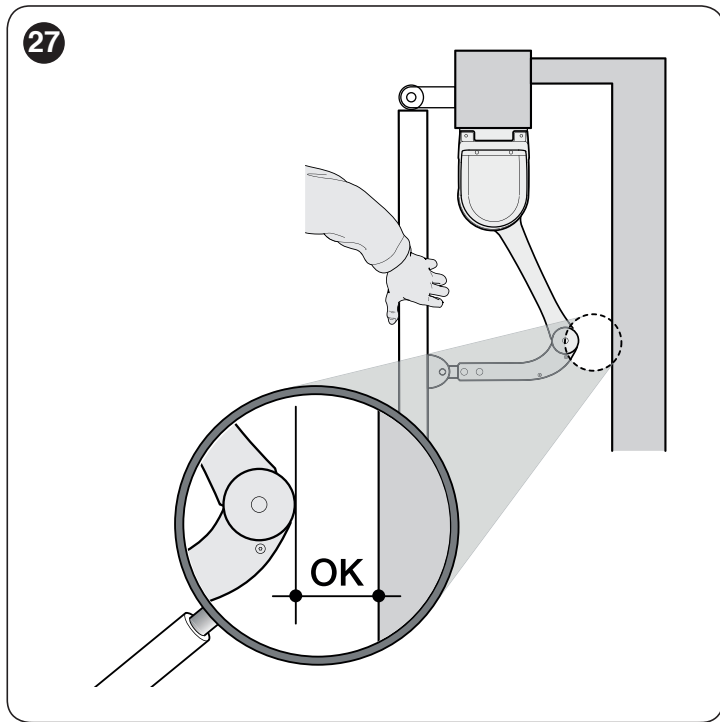

11. drill the leaf
12. separate the fixing bracket from the curved arm by removing the retaining ring and the relative pin

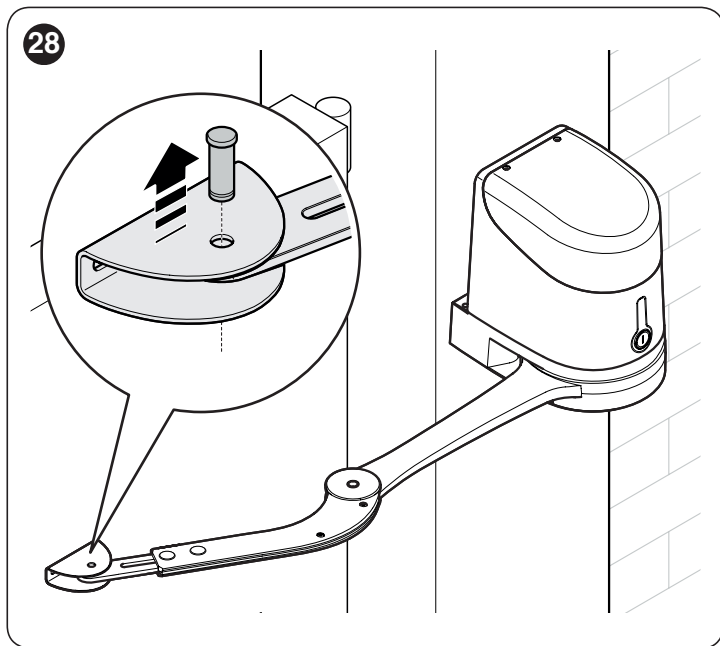

13. fasten the bracket to the gate leaf in the horizontal position, using adequate screws (not supplied)

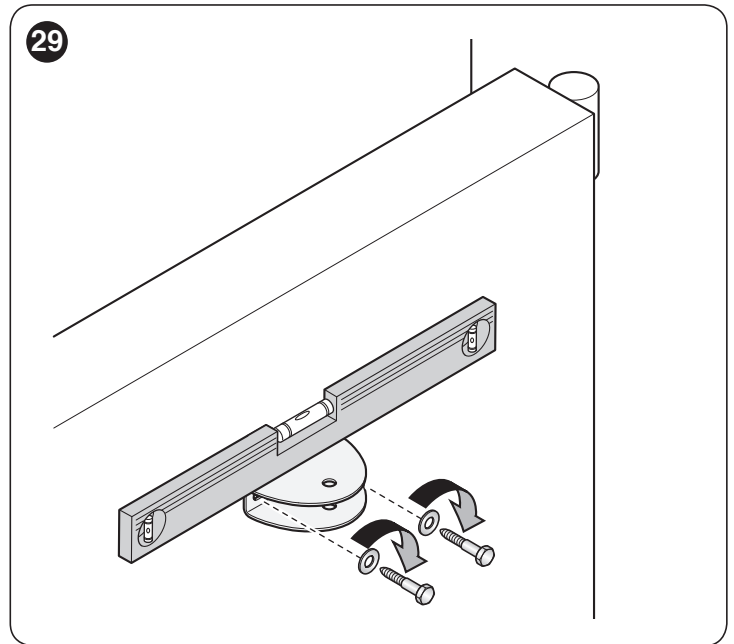

14. fasten the arm to the bracket again using the pin and retaining ring just removed
15. before locking the gearmotor, adjust the limit switches (see paragraph "**Adjusting the mechanical limit switches**")
16. manually bring the gate leaf to roughly midway along its path and lock the gearmotor as explained in the paragraph "**Manually unlocking and locking the gearmotor**". Then manually move the gate leaf by a few centimetres in the opening direction

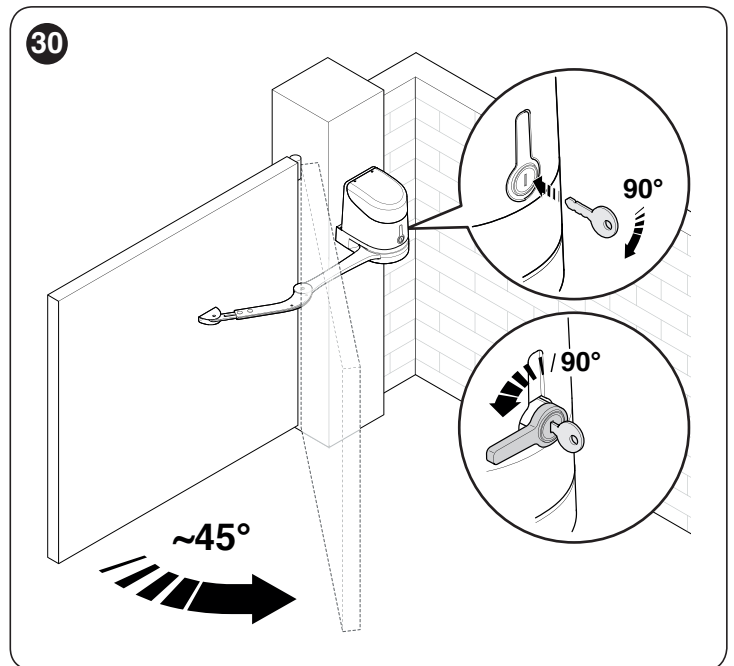

17. if the gate to be automated has two leaves, repeat all the operations described above to install the other gearmotor.

3.6 ADJUSTING THE MECHANICAL LIMIT SWITCHES

To adjust the limit switches, proceed as follows:

1. unlock the gearmotor with the relevant key provided (refer to the **"Manually unlocking and locking the gearmotor"** paragraph)
2. manually move the gate leaves to the fully open position
3. turn the plastic disc (A), located on the lower part of the gearmotor, moving the slot under the arm to the position shown

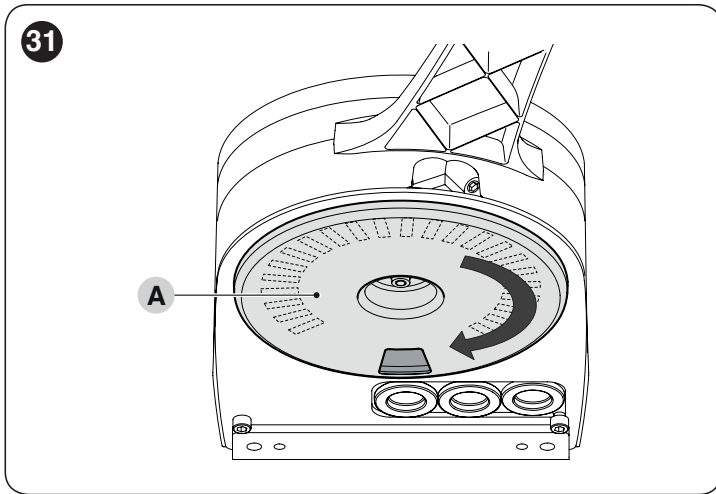

4. insert the limit switch (B) in the first available position: try inserting it as indicated

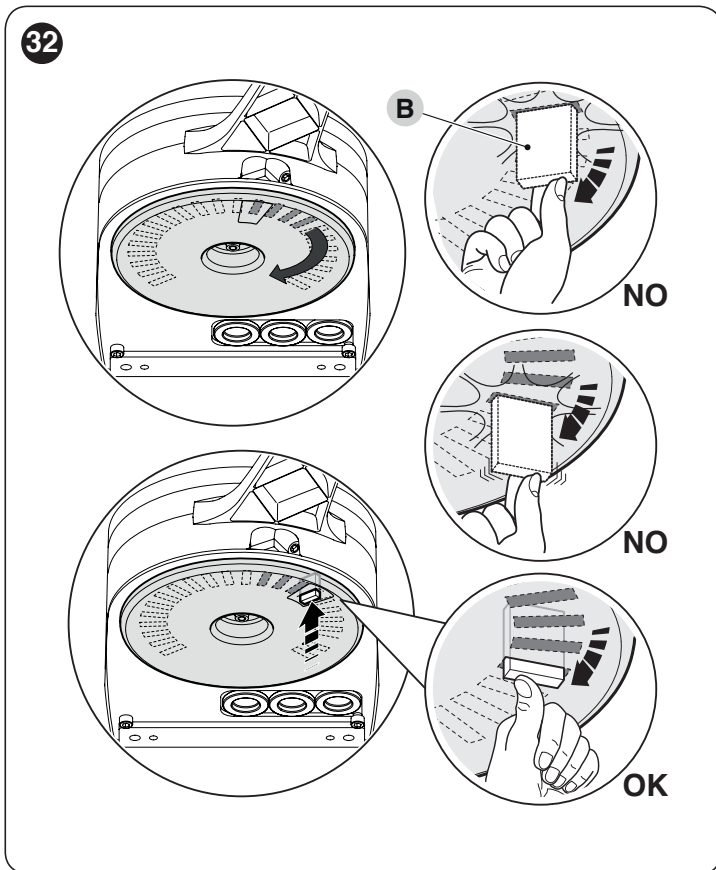

5. turn the disc (A) so that the limit switch does not fall and move the slot towards the position shown in **"Figure 31"**. For a finer adjustment, turn the adjustment screw (C)

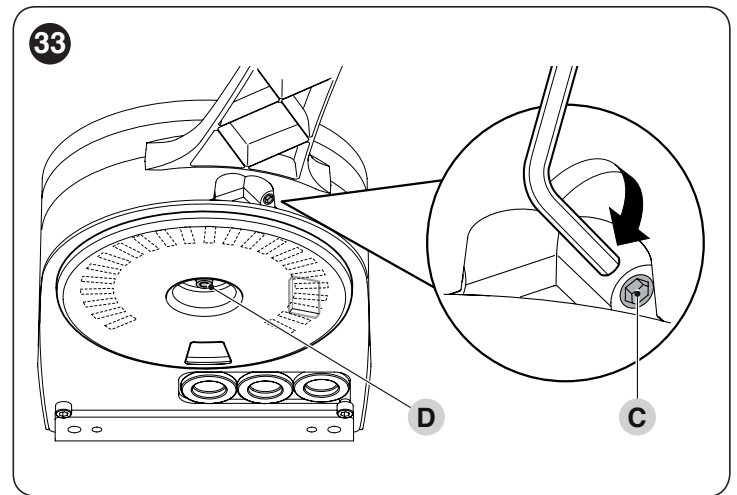

Hand icon: If the system has no closing stop on the ground, the entire procedure must be repeated to adjust the closing limit switch as well

6. fully tighten the nut fastening the disc (D) to prevent the latter from turning accidentally.

3.7 MANUALLY UNLOCKING AND LOCKING THE GEARMOTOR

The gearmotor is equipped with a mechanical unlocking device that can be used to open and close the gate manually. These manual operations should only be performed in case of a power outage, malfunctions or during the installation phases.

To unlock the device:

1. insert the key (A) and turn it clockwise by 90°
2. turn the lever (B) by 90° anti-clockwise which, by effect of a spring, has come out of its housing

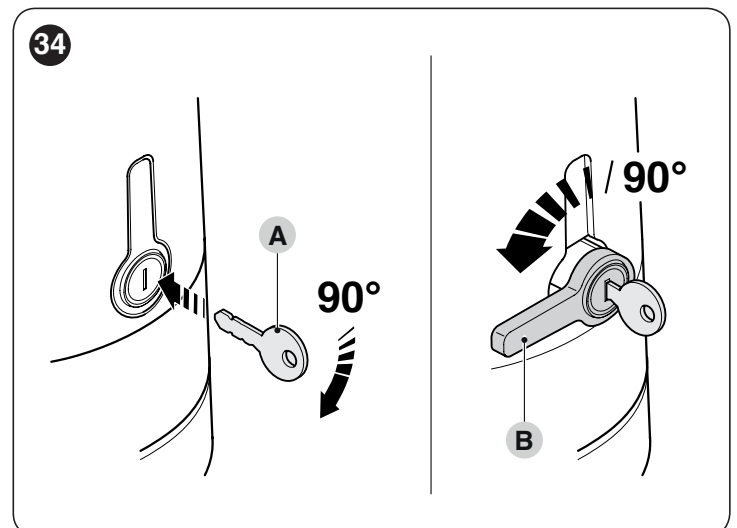

3. the gate leaf can now be moved manually to the desired position.

To lock the device:

1. turn the lever (B) by 90° until it lies in the vertical position
2. push the lever until it slots into its housing
3. turn the key (A) by 90° anti-clockwise
4. remove the key.

4 ELECTRICAL CONNECTIONS

4.1 PRELIMINARY CHECKS

 All electrical connections must be made with the system disconnected from the mains electricity and with the back-up battery (if present) disconnected.

 The connection operations must only be carried out by qualified personnel.

 Mount a device on the electric power line that completely disconnects the automation from the grid.

- The disconnection device must have contacts with a sufficient gap to ensure complete disconnection, under the Category III overvoltage conditions, in accordance with the installation instructions.

To make the electrical connections:

1. open the gearmotor's cover (A)

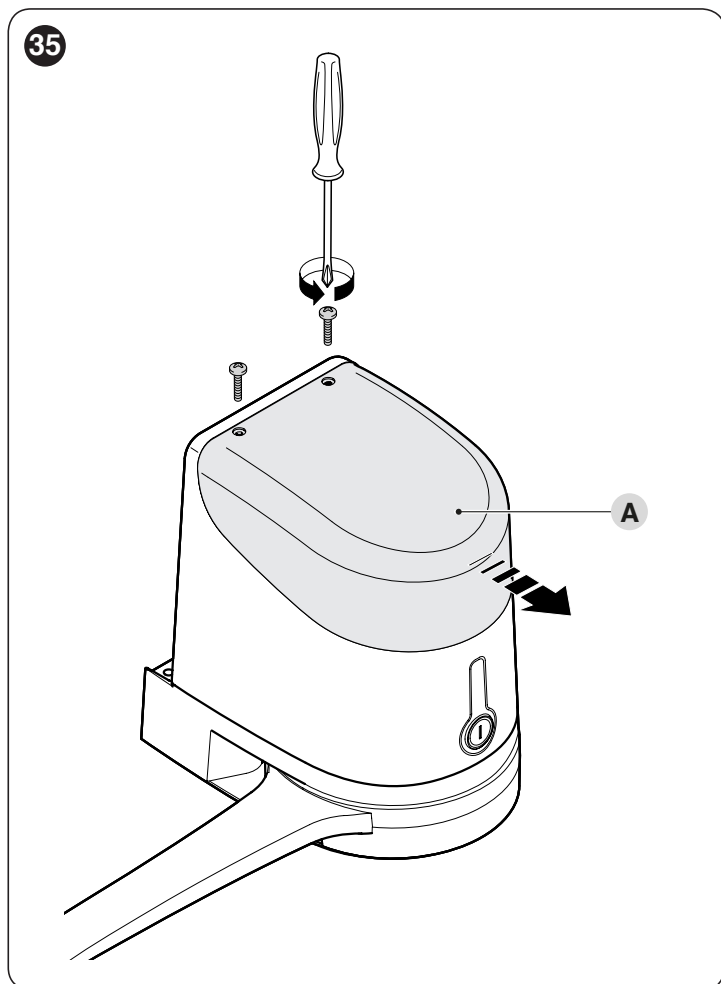

2. lift the control unit (B) of the gearmotor

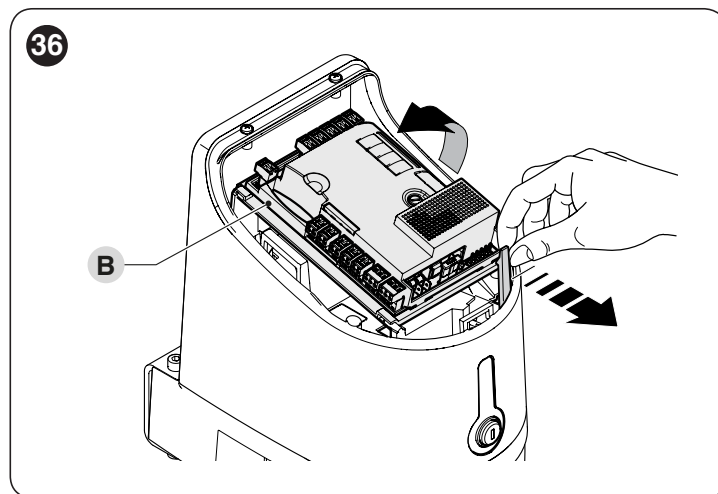

3. pass the power cable and the other electrical cables through the hole on the lower part of the gearmotor

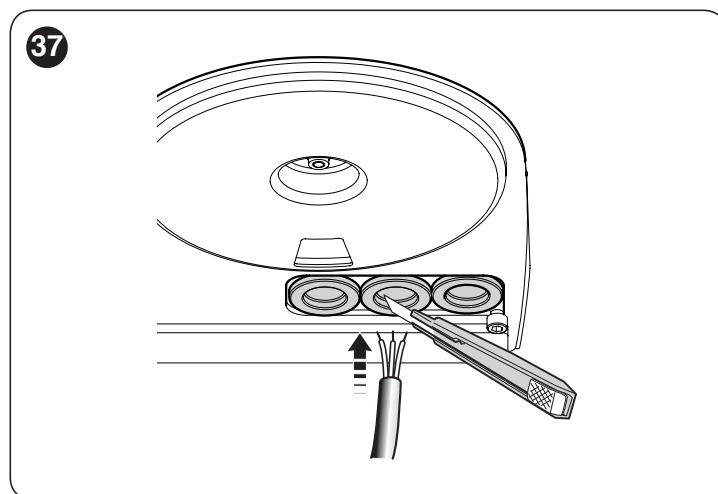

4. first connect the motor's power cable with control units HK7024 and HK7024HS: loosen the cable clamp (C)

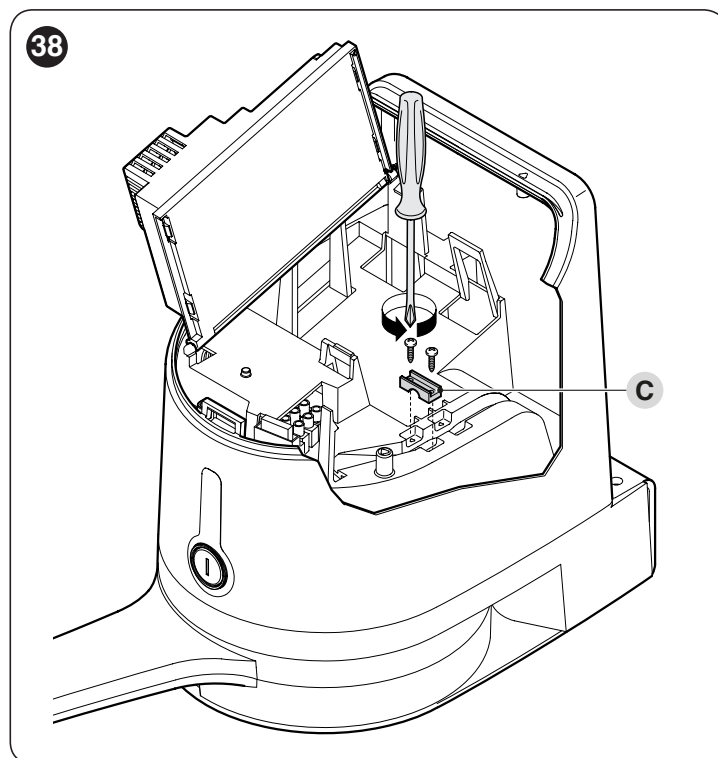

5. connect the power cable (D) and lock it in place with the cable clamp (C)

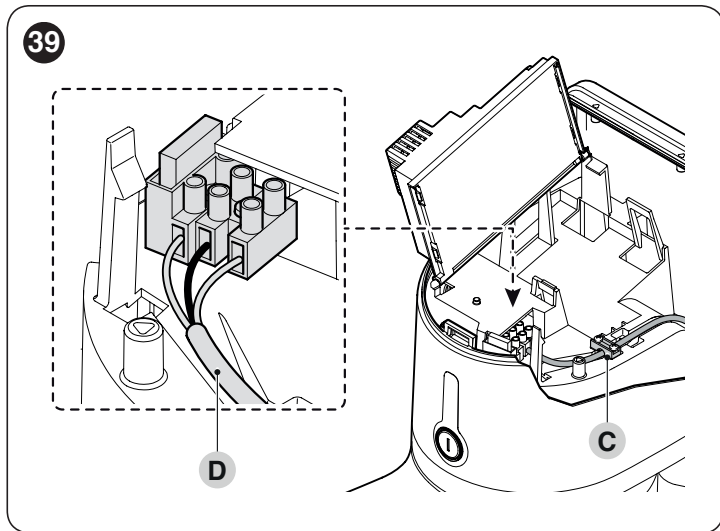

6. use the same procedure to connect the power cable to the motor without the control units **HK7224** and **HK7224HS**
7. connect the cables of any supplementary devices, by referring to "**Figure 41**" and to the "**Photocells**" paragraph

8. close the covers of the gearmotor.

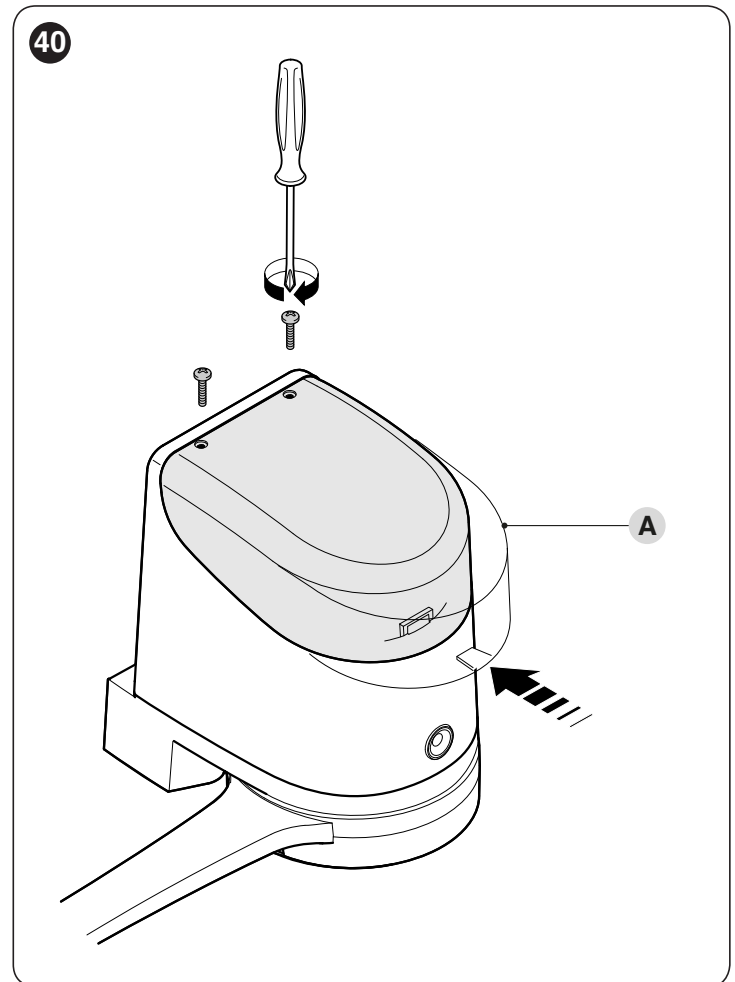

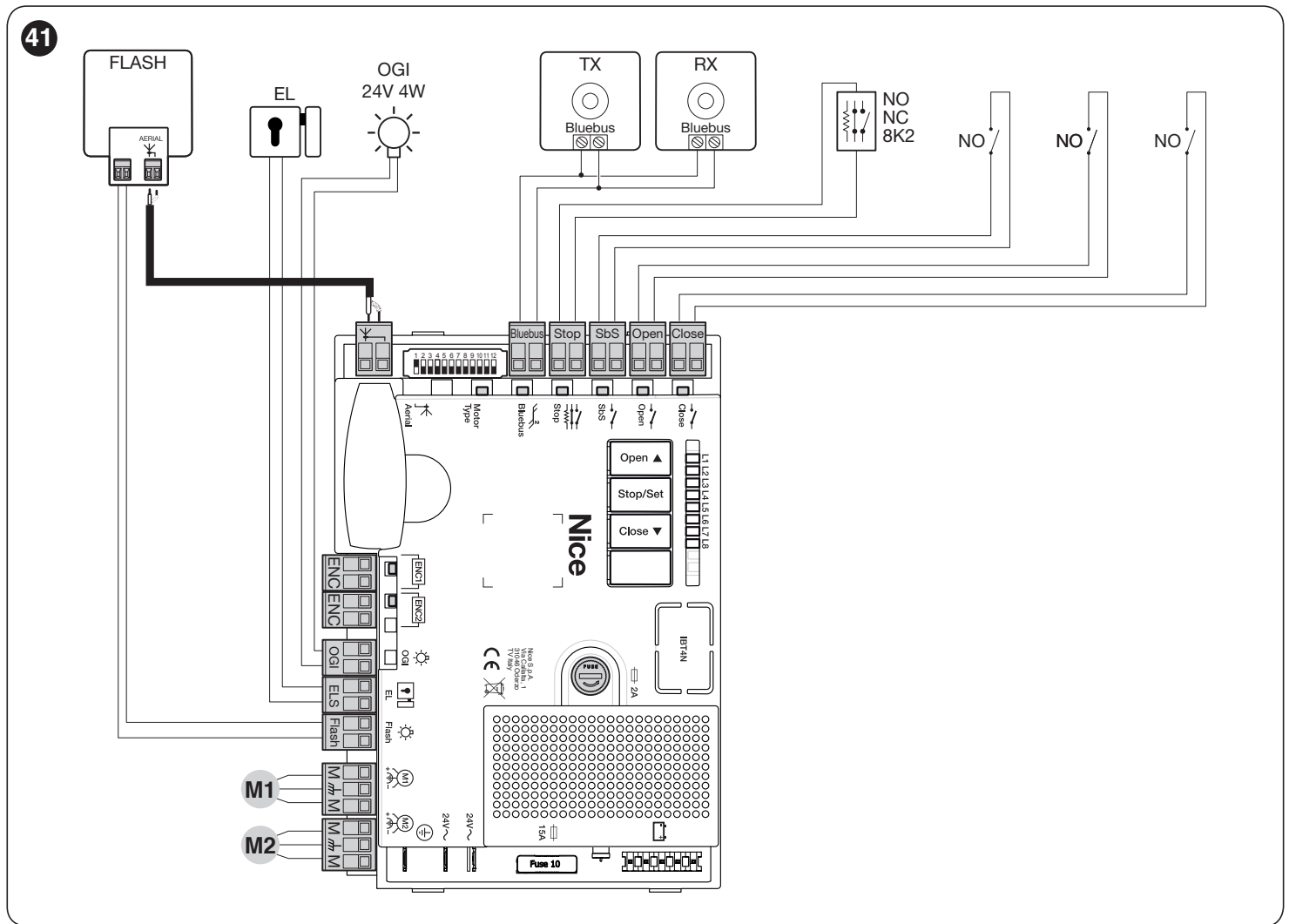

4.2 WIRING DIAGRAM AND DESCRIPTION OF CONNECTIONS

4.2.1 Wiring diagram



4.2.2 Description of connections

Table 3

ELECTRICAL CONNECTIONS	
Terminals	Description
M  M	Connection of motor M1 [note 1]
M  M	Connection of motor M2
Flash	Output for warning light mounting a 12 V (maximum 21 W) lamp. The output can be programmed (refer to the “ Level 1 programming (ON-OFF) ” paragraph).
ELS	Output for 12 V~ (maximum 15 VA) electric lock. The output can be programmed (refer to the “ Level 1 programming (ON-OFF) ” paragraph).
OGI	“Open Gate Indicator” output for 24 V maximum 4 W signalling lamp. The output can be programmed (refer to the “ Level 1 programming (ON-OFF) ” paragraph).
ENC	Motor 1 encoder input. No pole markings to observed
ENC	Motor 2 encoder input. No pole markings to observed
	Radio receiver antenna connection
Bluebus	Input for compatible devices (for example: EPLB, EPLOB, EPLIOB, ETPB, EDSB). The devices must be connected in parallel through two conductors carrying both the power supply and the communication signals. It is not necessary to observe the pole markings. During the learning function, each device connected to the control unit will be individually recognised thanks to a univocal code. Whenever a device is added or eliminated, the control unit must run the learning procedure (see “ Device learning ” paragraph).

Note 1 Not used for single-leaf gates (the control unit automatically recognises whether there is only one motor installed).

ELECTRICAL CONNECTIONS	
Terminals	Description
Stop	Input for devices that through their intervention trigger the immediate stoppage of the current manoeuvre followed by a brief reversal. NO (normally open) contacts, NC (normally closed) contacts or devices with 8.2 kΩ fixed resistor output, such as sensitive edges, can be connected to this input. Each device connected to this input will be individually recognised by the control unit during the learning phase (see " Device learning " paragraph). During this phase, if the control unit detects any variation with respect to the learned status, it triggers a STOP. One or more devices, even different from one another, can be connected to this input: any number of NO inputs in parallel; any number of NC inputs in series; 2 devices with 8.2 kΩ fixed resistor output in parallel. If there are more than 2 devices, they must all be connected in cascade mode with a single 8.2 kΩ terminating resistor; 2 NO and NC devices in parallel, putting an 8.2 kΩ resistor in series with the NC contact (this also allows for combining 3 devices: NO, NC and 8.2 kΩ).
SbS	Input for a NO (normally open) button, for sending commands in step-by-step mode.
Open	Input for command devices that trigger the opening manoeuvre only, when they intervene. NO (normally open) contacts can be connected to this input.
Close	Input for command devices that trigger the closing manoeuvre only, when they intervene. NO (normally open) contacts can be connected to this input.

5 FINAL CHECKS AND START-UP

It is advisable to position the leaf approximately halfway along its path before starting the automation check and start-up phases, so that the leaf is free to open and close.

5.1 POWER SUPPLY CONNECTION



The power supply connections must only be made by qualified and experienced personnel possessing the necessary requirements and in full conformity to the laws, regulations and standards in force.

As soon as the product is powered, a few simple checks should be carried out:

1. check that the "**BlueBUS**" LED flashes regularly with one flash per second
2. check that the LEDs on the photocells (both the TX and RX) also flash; the type of flashing is irrelevant, since it depends on other factors
3. check that the warning light connected to the FLASH output is off.

If the above conditions are not satisfied, immediately switch off the power supply to the control unit and carefully check the electrical connections.

Further useful information on searching and diagnosing faults is included in the "**TROUBLESHOOTING GUIDE**" chapter.

5.2 DEVICE LEARNING

After the initial start-up, the control unit must recognise the devices connected to the "**Bluebus**" and "**Stop**" inputs.



The learning phase must be carried out even if no device is connected to the control unit.

The control unit can individually recognise the various devices connected, thanks to the learning procedure, and detect possible anomalies.

For this to occur, the device learning procedure must be carried out whenever a device is added or removed.

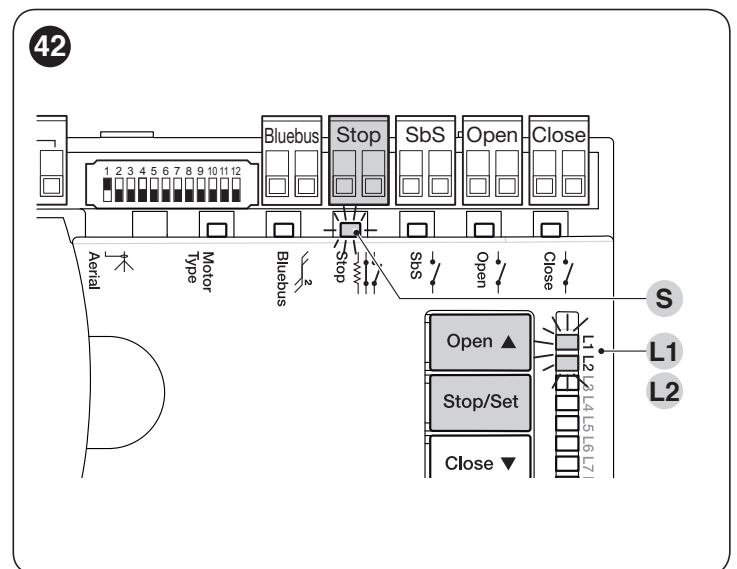

LEDs "**L1**" and "**L2**" on the control unit ("**Figure 42**") emit some slow flashes to signal that the learning procedure must be carried out.

To do this:

1. simultaneously press and hold the [**Open ▲**] and [**Stop/Set**] buttons
2. release the buttons when LEDs "**L1**" and "**L2**" start flashing quickly (after roughly 3 seconds)
3. wait a few seconds until the control unit has completed the device learning phase
4. once this phase terminates, the "**Stop**" (**S**) LED must be lit and LEDs "**L1**" and "**L2**" must switch off (LEDs "**L3**" and "**L4**" could start flashing).

5.3 MOTOR SELECTOR

The control unit is equipped with a selector (**A** - "Figure 43") that allows for specifying which type of motor to use (see "Table 4").

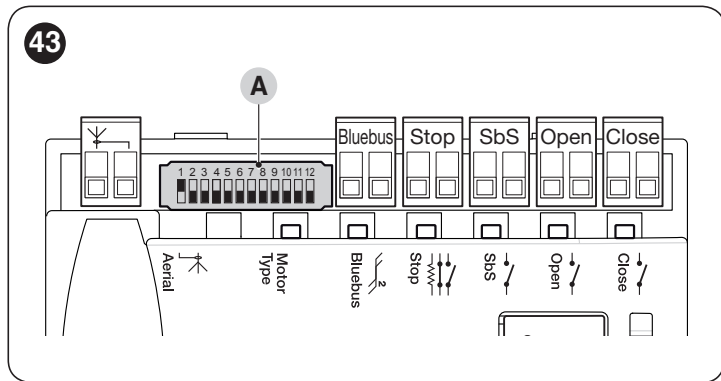

The motor selector must be set before activating the mechanical stop learning function.

Any configuration not appearing in "Table 4" is not allowed.

Table 4

SELECTING THE MOTOR TYPE		
Motor type	Motor selector	Visualisation on Oview
HK7024		HYKE
HK7024HS		HYKEHS

5.4 LEARNING OF THE MECHANICAL STOP POSITIONS

Once the connected devices have been learned, the mechanical stop positions must be learned (maximum opening and maximum closing). This procedure can be carried out in three different ways: **automatic**, **manual** and **mixed**.

In **automatic** mode, the control unit learns the mechanical stops, calculates the most appropriate gate leaf offsets and calculates the slowdown points "SA" and "SC" ("Figure 44").

Before starting the self-learning procedure in automatic mode, verify that the motor force is suited to the type of motor being used (see paragraph "Level 2 programming (adjustable parameters) - Function L5").

In the **manual** mode, the positions ("Figure 44") are programmed one by one, by shifting the leaves to the desired points. The position to be programmed can be identified when one of the eight LEDs "L1...L8" flashes (see "Table 5").

In the **mixed** mode, it is possible to perform the automatic procedure and then, with the manual procedure, modify one or more positions with the exception of the "0" and "1" positions, which correspond to the mechanical stop positions.

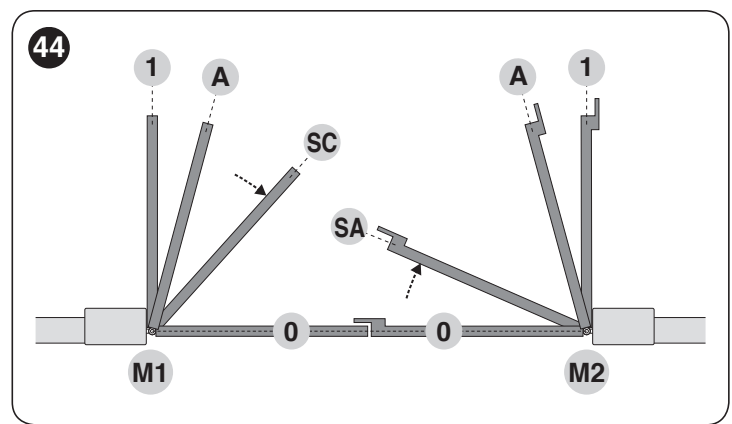
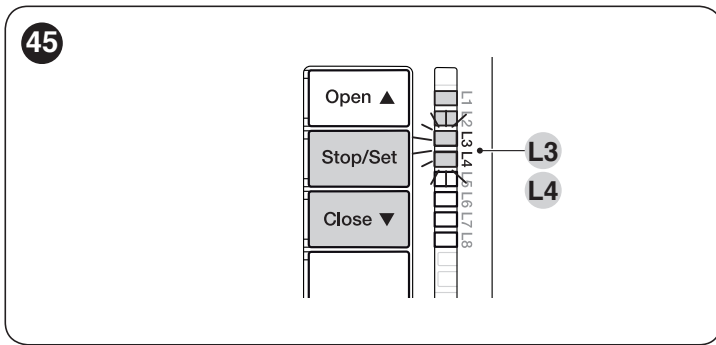

Table 5

PROGRAMMING POSITIONS		
Position	LED	Description
Position 0 (motor 1)	L1	maximum closing position: when the leaf relative to motor 1 strikes the closing mechanical stop
Position 0 (motor 2)	L2	maximum closing position: when the leaf relative to motor 2 strikes the closing mechanical stop
Position SA (motor 2)	L3	Offset on opening: when the leaf associated with motor 2 moves beyond this position, leaf 1 will start to open
Position A (motor 1)	L4	Desired opening position: position in which the leaf associated with motor 1 must stop at the end of an opening manoeuvre. This position must not necessarily correspond to the opening mechanical stop; it can be chosen as desired between positions "0" and "1"
Position A (motor 2)	L5	Desired opening position: position in which the leaf associated with motor 2 must stop at the end of an opening manoeuvre. This position must not necessarily correspond to the opening mechanical stop; it can be chosen as desired between positions "0" and "1"
Position SC (motor 1)	L6	Offset on closing: when leaf 1 is below this position, leaf 2 will start to close
Position 1 (motor 1)	L7	Maximum opening position: when the leaf relative to motor 1 strikes the opening mechanical stop
Position 1 (motor 2)	L8	Maximum opening position: when the leaf relative to motor 2 strikes the opening mechanical stop

5.4.1 Learning in automatic mode



To effect the automatic learning procedure:

1. simultaneously press and hold the and **[Stop/Set]** buttons **[Close ▼]**
2. release the buttons when LEDs “L3” and “L4” start flashing quickly (after roughly 5 seconds)
3. check that the automation carries out the following manoeuvre sequences:
 - a. slow closing of motor M1 up to the mechanical stop
 - b. slow closing of motor M2 up to the mechanical stop
 - c. slow opening of motor M2 and of motor M1 up to the stop
 - d. fast closing of motors M1 and M2.



If the first manoeuvre (a) fails to close the leaf controlled by motor M1 but closes the one controlled by M2, press **[Open ▲]** or **[Close ▼]** to stop the learning phase. At this point, reverse the connections of motors M1 and M2 on the terminals on the control unit and those of the respective encoders. Then repeat the self-learning procedure.



If the first two manoeuvres (a and b) are not “closing” but “opening” manoeuvres, press the **[Open ▲]** or **[Close ▼]** button to stop the learning phase. At this point, invert the control wires (external positions with respect to the terminal) on the motor that executed the opening manoeuvre and repeat the self-learning procedure.

4. at the end of the closing manoeuvre (d) of the two motors, LEDs “L3” and “L4” switch off to signal that the procedure was performed correctly.



If, during the automatic learning procedure, the photocells or one of the devices connected to the “stop” input intervene, the procedure interrupts and LED L1 starts flashing. In this case, the self-learning procedure must be repeated from the beginning.



The automatic learning procedure can be run again at any time, even after the installation phase; for example, after modifying the position of the mechanical stops.

5.4.2 Learning in manual mode



The user has maximum 10 seconds to press the buttons consecutively during the learning procedure. After this time, the procedure terminates automatically and memorises the changes made up to that time.

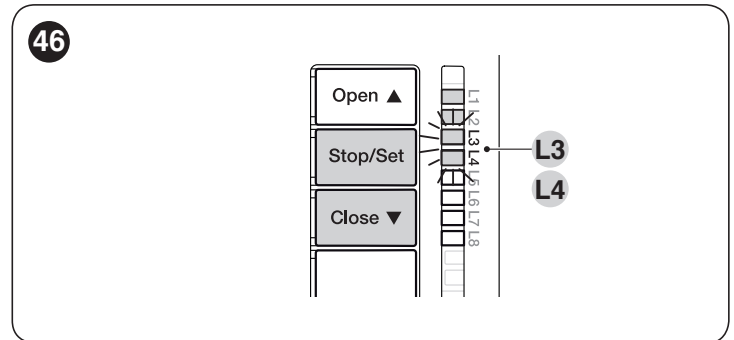

When LEDs “L1..L8” flash, to shift between LEDs simply press the **[Open ▲]** or **[Close ▼]** button briefly (the LED will flash to signal the current position).



While LEDs “L1..L8” flash, to move the motor in any one direction, it is necessary to press and hold the **[Open ▲]** or **[Close ▼]** button.

To effect the manual learning procedure:

1. simultaneously press and hold the and **[Stop/Set]** buttons **[Close ▼]**
2. release the buttons when LED “L1” starts flashing (after roughly 3 sec)
3. LED “L1” flashes: **position 0 of M1**
 - to command and move motor 1 to **position “0”** (“Figure 44”): press and hold the **[Open ▲]** or **[Close ▼]** button. Once the position is reached, release the button to stop the manoeuvre
 - to memorise the position, press and hold the **[Stop/Set]** button for at least 3 seconds then release it (after 2 seconds LED “L1” will remain lit and after the **[Stop/Set]** button is released, LED “L2” will start flashing)
4. LED “L2” flashes: **position 0 of M2**
 - to command and move motor 2 to **position “0”** (“Figure 44”): press and hold the **[Open ▲]** or **[Close ▼]** button. Once the position is reached, release the button to stop the manoeuvre
 - to memorise the position, press and hold the **[Stop/Set]** button for at least 3 seconds then release it (after 2 seconds LED “L2” will remain lit and after the **[Stop/Set]** button is released, LED “L3” will start flashing)
5. LED “L3” flashes: **position SA of M2**
 - to command and move motor 2 to **position “SA”** (“Figure 44”): press and hold the **[Open ▲]** or **[Close ▼]** button. Once the position is reached, release the button to stop the manoeuvre
 - to memorise the position, press and hold the **[Stop/Set]** button for at least 3 seconds then release it (after 2 seconds LED “L3” will remain lit and after the **[Stop/Set]** button is released, LED “L4” will start flashing)

6. LED "L4" flashes: **position A of M1**
 - to command and move motor 1 to **position "A"** ("Figure 44"): press and hold the [Open ▲] or [Close ▼] button. Once the position is reached, release the button to stop the manoeuvre
 - to memorise the position, press and hold the [Stop/Set] button for at least 3 seconds then release it (after 2 seconds LED "L4" will remain lit and after the [Stop/Set] button is released, LED "L5" will start flashing)
7. LED "L5" flashes: **position A of M2**
 - to command and move motor 2 to **position "A"** ("Figure 44"): press and hold the [Open ▲] or [Close ▼] button. Once the position is reached, release the button to stop the manoeuvre
 - to memorise the position, press and hold the [Stop/Set] button for at least 3 seconds then release it (after 2 seconds LED "L5" will remain lit and after the [Stop/Set] button is released, LED "L6" will start flashing)
8. LED "L6" flashes: **position SC of M1**
 - to command and move motor 1 to **position "SC"** ("Figure 44"): press and hold the [Open ▲] or [Close ▼] button. Once the position is reached, release the button to stop the manoeuvre
 - to memorise the position, press and hold the [Stop/Set] button for at least 3 seconds then release it (after 2 seconds LED "L6" will remain lit and after the [Stop/Set] button is released, LED "L7" will start flashing)
9. LED "L7" flashes: **position 1 of M1**
 - to command and move motor 1 to **position "1"** ("Figure 44"): press and hold the [Open ▲] or [Close ▼] button. Once the position is reached, release the button to stop the manoeuvre
 - to memorise the position, press and hold the [Stop/Set] button for at least 3 seconds then release it (after 2 seconds LED "L7" will remain lit and after the [Stop/Set] button is released, LED "L8" will start flashing)
10. LED "L8" flashes: **position 1 of M2**
 - to command and move motor 2 to **position "1"** ("Figure 44"): press and hold the [Open ▲] or [Close ▼] button. Once the position is reached, release the button to stop the manoeuvre
 - to memorise the position, press and hold the [Stop/Set] button for at least 3 seconds then release it (after 2 seconds, LED "L8" will remain lit and after the [Stop/Set] button is released).



If the system has a single motor only:

- proceed as described at points 1 and 2
- at points 3 and 9, press and hold the [Stop/Set] button for at least 3 seconds then release it
- after 2 seconds, the relative LED will remain lit until the [Stop/Set] button is released. The next LED will then start flashing.

Do not programme the positions relative to LEDs L3 (SA of M2), L4 (A of M1) and L6 (SC of M1). To shift between LEDs, simply press the [Open ▲] or [Close ▼] button briefly (the LED will flash to signal the current position).

5.4.3 Learning in mixed mode



The user has maximum 10 seconds to press the buttons consecutively during the learning procedure. After this time, the procedure terminates automatically and memorises the changes made up to that time.

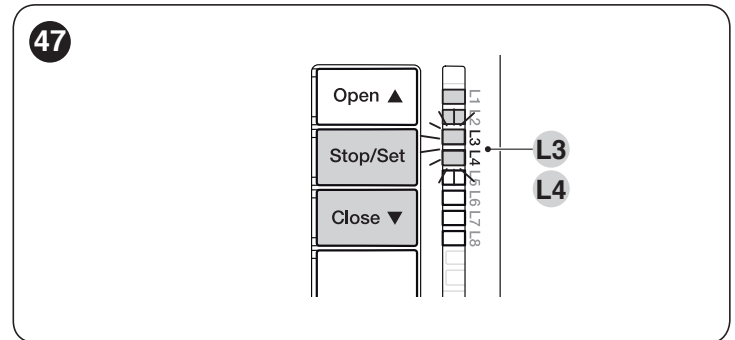

To effect the learning procedure in mixed mode:

1. run the self-learning procedure in automatic mode as described under the "**Learning in automatic mode**" paragraph
2. simultaneously press and hold the and [Stop/Set] buttons [Close ▼]
3. release the buttons when LED "L1" starts flashing
4. briefly press the [Open ▲] or [Close ▼] button to shift the flashing LED (L1...L8) to the position to be programmed
5. repeat this last operation for all the other positions to be modified
6. to terminate the manual learning procedure, press the [Close ▼] button repeatedly to shift the LED that flashes to beyond position "L8".

5.5 CHECKING THE GATE MOVEMENT

At the end of the learning phase, we recommend letting the control unit run a few opening and closing manoeuvres to verify whether the gate moves correctly and if there are any assembly and adjustment defects.

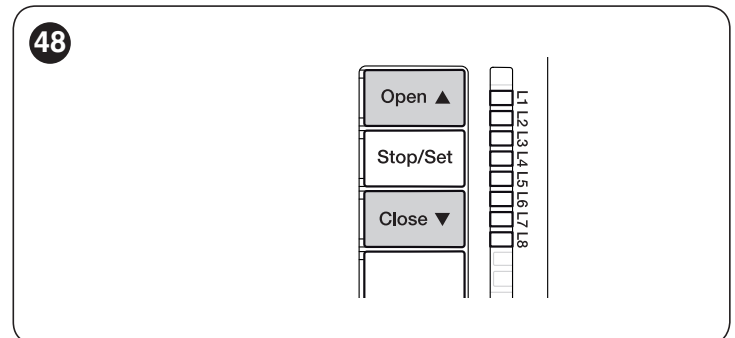

1. To do this:
2. press the [Open ▲] button ("Figure 48"). Check that the acceleration, constant-speed and slowdown phases are present during the opening manoeuvre. Once the manoeuvre terminates, the gate leaves must stop a few centimetres from the opening mechanical stop
3. press the [Close ▼] button ("Figure 48") and verify that the acceleration, constant-speed and slowdown phases are present during the closing manoeuvre. Once the manoeuvre terminates, the gate leaves must be perfectly closed on the closing mechanical stop
4. check that all the previously adjusted functions have been learned by the control unit.

5.6 CONNECTING OTHER DEVICES TO THE CONTROL UNIT

In any additional devices belonging to the system (e.g. transponder card reader, light for the key selector, etc.) must be powered, they can be connected to the control unit using terminals “SbS (positive)” and “Stop (negative)” (“Figure 41”). The power supply voltage is 24 V_{DC} with a maximum available current of 200 mA.



The voltage available at the “SbS” and “STOP” terminals remains even when the “Stand-by” function is enabled on the board.

6 TESTING AND COMMISSIONING

These are the most important phases of the automation's construction, as they ensure maximum safety of the system. The test can also be used to periodically verify the devices making up the automation.



Testing and commissioning of the automation must be performed by skilled and qualified personnel, who are responsible for the tests required to verify the solutions adopted according to the risks present, and for ensuring that all legal provisions, standards and regulations are met, in particular all the requirements of the EN 12445 standard, which defines the test methods for checking gate automations.

The additional devices must undergo specific testing, both in terms of their functions and their proper interaction with the control unit. Refer to the instruction manuals of the individual devices.

6.1 TESTING

To run the test:

1. verify that all the instructions stated in the “**GENERAL SAFETY WARNINGS AND PRECAUTIONS**” chapter have been strictly observed
2. unlock the gearmotor as indicated in the “**Manually unlocking and locking the gearmotor**” paragraph
3. make sure that the leaf can be moved manually during both the opening and closing phases with a force not exceeding 390N (roughly 40 kg)
4. lock the gearmotor
5. using the control devices (transmitter, control button, key selector, etc.), test the gate's opening, closing and stoppage movements to make sure that the leaves move as intended. Several tests should be carried out to assess the movement of the leaves and detect any defects in the installation and adjustment, besides any points of excessive friction
6. check, one-by-one, that all safety devices mounted on the system (photocells, sensitive edges, etc.) work properly. Each time a device intervenes, the “**Bluebus**” LED on the control unit will emit two faster flashes to confirm the recognition
7. if potentially dangerous situations due to the movement of the leaves have been prevented by limiting the impact force, the latter must be measured according to the EN 12445 standard and, if the “motor force” control is used to aid the system in reducing the impact force, it is necessary to test various adjustments to find the one that gives the best results.

6.2 COMMISSIONING



Commissioning can only be performed after all testing phases have been successfully completed.



Before commissioning the automation, ensure that the owner is properly informed of all residual risks and hazards.



The gate cannot be commissioned partially or under “temporary” conditions.

To commission the automation:

1. compile the automation's technical file, which must include the following documents: overall drawing of the automation, wiring diagram, risk assessment and relative solutions adopted, the manufacturer's declaration of conformity for all devices used and the declaration of conformity compiled by the installer
2. affix a permanent label or sign near the gate specifying the operations for unlocking the gate and manoeuvring it manually “Figure 49”

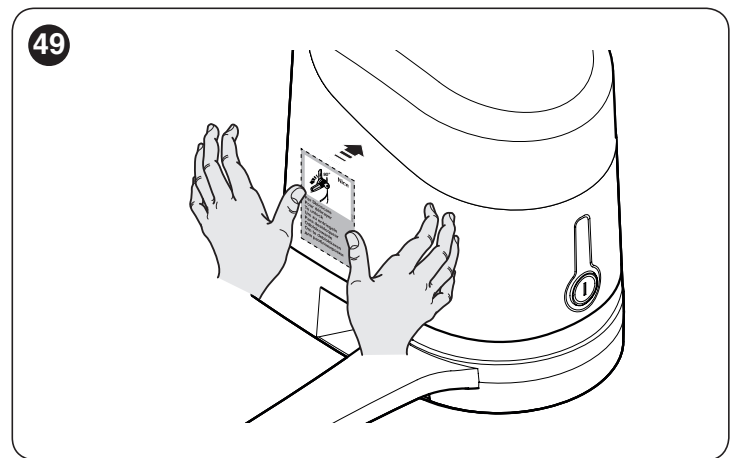

3. affix a data plate on the gate specifying at least the following data: type of automation, name and address of the manufacturer (responsible for commissioning), serial number, year of manufacture and CE mark
4. compile the declaration of conformity of the automation and hand it to the owner of the automation
5. compile the User Manual of the automation and hand it to the owner of the automation
6. compile and provide the owner with the automation's “Maintenance schedule”, containing the maintenance instructions for all the automation's devices.



For all the above-mentioned documentation, Nice – through its technical assistance service – provides the following: pre-completed forms.

7 PROGRAMMING

There are 3 buttons on the control unit: **[Open ▲]**, **[Stop/Set]** and **[Close ▼]** (“*Figure 50*”) which can be used both to command the control unit during the testing phase and to programme the available functions.

The **[Radio]** button is not used.

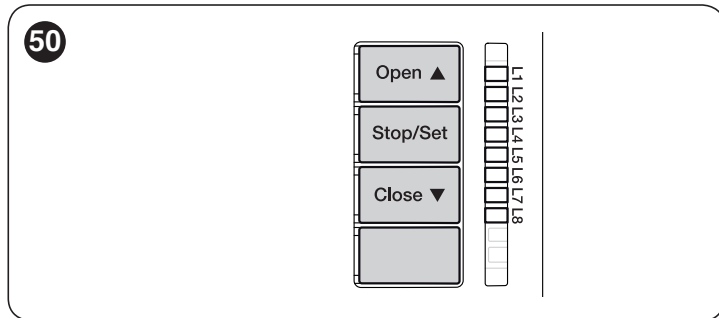

The available programmable functions are grouped into **two levels** and their operating status is signalled by eight LEDs “**L1 ... L8**” located on the control unit (LED lit = function enabled; LED off = function disabled).

7.1 USING THE PROGRAMMING BUTTONS

[Open ▲] Button for commanding the gate opening
Selection button during the programming phase.

[Stop/Set] Button used to stop a manoeuvre
If pressed for more than 5 seconds, it allows for entering the programming mode.

[Close ▼] Button for commanding the gate’s closure
Selection button during the programming phase.

[Radio]
– Button not used.

7.2 LEVEL 1 PROGRAMMING (ON-OFF)

All the Level 1 functions are factory-set to “**OFF**” and can be modified at any time. To check the various functions, refer to “*Table 6*”.

7.2.1 Level 1 programming procedure



The user has maximum 10 seconds to press the buttons consecutively during the programming procedure, after which time the procedure terminates automatically and memorises the changes made up to then.

To perform Level 1 programming:

1. press and hold the **[Stop/Set]** button until LED “**L1**” starts flashing
2. release the **[Stop/Set]** button when LED “**L1**” starts flashing
3. press the **[Open ▲]** or **[Close ▼]** button to move the flashing LED to the LED associated with the function to be modified
4. press the **[Stop/Set]** button to change the status of the function:
 - short flash = **OFF**
 - long flash = **ON**
5. wait 10 seconds (maximum time) to exit the programming mode.



To set other functions to “ON” or “OFF”, while the procedure is running, repeat points 2 and 3 during the phase itself.

Table 6

LEVEL 1 FUNCTIONS (ON-OFF)		
LED	Function	Description
L1	Automatic closing	Function ENABLED: after an opening manoeuvre there is a pause (equal to the set pause time), after which the control unit automatically starts a closing manoeuvre. The pause time is set by default to 30 seconds. Function NOT ENABLED: the system works in “semi-automatic” mode.
L2	Close after photo	Function ENABLED: if the photocells intervene during the opening or closing manoeuvre, the pause time drops to 5 seconds regardless of the set “pause time”. With “automatic closing” disabled, if the photocells intervene during the opening or closing manoeuvre, the “automatic closing” activates with the set “pause time”.
L3	Always Close	Function ENABLED: in the event of a blackout, even of short duration, 10 seconds after the electricity is restored the control unit detects that the gate is open and automatically starts a closing manoeuvre, preceded by 5 seconds of pre-flashing. Function DISABLED: when the electricity is restored, the gate remains in the same position.
L4	Stand-by all	Function ENABLED: 1 minute after the manoeuvre is completed, the control unit will turn off the “Bluebus” output (connected devices) and all the LEDs, with the exception of the Bluebus LED, which will flash at a slower speed. When the control unit receives a command, it restores normal operation (with a short delay). This function is used to reduce consumption – an important aspect when the unit is powered by batteries or photovoltaic panels.

LEVEL 1 FUNCTIONS (ON-OFF)		
LED	Function	Description
L5	Warning / Courtesy light	Function ENABLED: the “electric lock” output switches its operation to “courtesy light”. Function NOT ENABLED: the output functions as an electric lock.
L6	Pre-flashing	Function ENABLED: the warning light starts flashing 3 seconds before the start of the manoeuvre to signal in advance a dangerous situation. Function NOT ENABLED: the warning light starts flashing when the manoeuvre starts.
L7	“Close” becomes “Partial Open 1”	Function ENABLED: the “Close” input of the control unit switches its operation to “Partial Open 1”.
L8	“Gate open indicator” or “Maintenance indicator”	Function ENABLED: the “gate open indicator” output of the control unit switches its operation to “maintenance indicator”. Function NOT ENABLED: the output functions as a “gate open indicator”.

7.3 LEVEL 2 PROGRAMMING (ADJUSTABLE PARAMETERS)

All the Level 2 parameters are factory-set as highlighted in “GREY” in “**Table 7**” and can be modified at any time. The parameters can be set to a scale of 1 to 8. The check the value corresponding to each LED, refer to “**Table 7**”.

7.3.1 Level 2 programming procedure



The user has maximum 10 seconds to press the buttons consecutively during the programming procedure, after which time the procedure terminates automatically and memorises the changes made up to then.

To perform Level 2 programming:

1. press and hold the [Stop/Set] button until LED “L1” starts flashing
2. release the [Stop/Set] button when LED “L1” starts flashing
3. press the [Open ▲] or [Close ▼] button to move the flashing LED to the “entry LED” associated with the parameter to be modified
4. press and hold the [Stop/Set] button. With the [Stop/Set] button pressed:
 - wait roughly 3 seconds, until the LED representing the current level of the parameter to be modified lights up
 - press the [Open ▲] or [Close ▼] button to shift the LED associated with the parameter’s value
5. release the [Stop/Set] button
6. wait 10 seconds (maximum time) to exit the programming mode.



To set multiple parameters during the procedure's execution, repeat the operations from point 2 to point 4 during the phase itself.



The set value highlighted in grey (“**Table 7**”) indicates that this value is the factory setting.

Table 7

LEVEL 2 FUNCTIONS (ADJUSTABLE PARAMETERS)				
Entry LED	Parameter	LED (level)	Set value	Description
L1	Pause Time	L1	5 seconds	Adjusts the pause time, in other words, the time that elapses before automatic re-closure. It is only effective if the Close function is enabled.
		L2	15 seconds	
		L3	30 seconds	
		L4	45 seconds	
		L5	60 seconds	
		L6	80 seconds	
		L7	120 seconds	
		L8	180 seconds	

LEVEL 2 FUNCTIONS (ADJUSTABLE PARAMETERS)				
Entry LED	Parameter	LED (level)	Set value	Description
L2	Step-by-Step function	L1	Open - Stop - Close - Stop	Controls the sequence of commands associated with the "SbS", "Open" and "Close" inputs or the radio control. Note: setting L4 , L5 , L7 and L8 , the behaviour of the "Open" and "Close" commands also changes.
		L2	Open - Stop - Close - Open	
		L3	Open - Close - Open - Close	
		L4	CONDOMINIUM During the opening manoeuvre , the "Step-by-Step" and "Open" commands do not cause any effect; instead the "Close" command causes the movement to reverse, namely the closing of the gate leaves. During the closing manoeuvre , the "Step-by-Step" and "Open" commands cause a reversal of the movement, namely the opening of the gate leaves; instead the "Close" command does not cause any effect.	
		L5	CONDOMINIUM 2 During the opening manoeuvre , the "Step-by-Step" and "Open" commands do not cause any effect; instead the "Close" command causes the movement to reverse, namely the closing of the gate leaves. <u>If the sent command remains for more than 2 seconds</u> , a "Stop" command is executed. During the closing manoeuvre , the "Step-by-Step" and "Open" commands cause a reversal of the movement, namely the opening of the gate leaves; instead the "Close" command does not cause any effect. <u>If the sent command remains for more than 2 seconds</u> , a "Stop" command is executed.	
		L6	STEP-BY-STEP 2 (less than 2 seconds causes partial opening)	
		L7	HOLD-TO-RUN The manoeuvre is only executed if the sent command remains; if the command is interrupted, the manoeuvre stops.	
		L8	"Semi-automatic" opening, "hold-to-run" closing.	
L3	Motor speed	L1	Very slow	Adjusts the motor speed during normal travel.
		L2	Slow	
		L3	Medium	
		L4	Fast	
		L5	Very fast	
		L6	Extremely fast	
		L7	Opens "Fast"; closes "Slow"	
		L8	Opens "Extremely fast"; closes "Medium"	
L4	Motor discharge after closing	L1	No discharge	Adjusts the duration of the "brief reversal" of both motors, after completing the closing manoeuvre, to reduce the residual final thrust.
		L2	Level 1 - Minimum discharge (roughly 100 ms)	
		L3	Level 2 - ...	
		L4	Level 3 - ...	
		L5	Level 4 - ...	
		L6	Level 5 - ...	
		L7	Level 6 - ...	
		L8	Level 7 - Maximum discharge (roughly 800 ms)	
L5	Motor force	L1	Level 1 - Minimum force	Adjusts the force of both motors.
		L2	Level 2 - ...	
		L3	Level 3 - ...	
		L4	Level 4 - ...	
		L5	Level 5 - ...	
		L6	Level 6 - ...	
		L7	Level 7 - ...	
		L8	Level 8 - Maximum force	
L6	Pedestrian or partial opening	L1	Pedestrian 1 (the M2 gate leaf opens to 1/4 of the full length)	Adjusts the type of opening associated with the "partial opening 1" command. In levels L5, L6, L7 and L8, "minimum" opening refers to the smallest opening between M1 and M2; for example, if M1 opens to 90° and M2 opens to 110°, the minimum opening is 90°.
		L2	Pedestrian 2 (the M2 gate leaf opens to 1/2 of the full length)	
		L3	Pedestrian 3 (the M2 gate leaf opens to 3/4 of the full length)	
		L4	Pedestrian 4 (full opening of gate leaf 2)	
		L5	Partial 1 (the two gate leaves open to 1/4 of the "minimum" opening level)	
		L6	Partial 2 (the two gate leaves open to 1/2 of the "minimum" opening level)	
		L7	Partial 3 (the two gate leaves open to 3/4 of the "minimum" opening level)	
		L8	Partial 4 (the two gate leaves open to the "minimum" opening level)	

LEVEL 2 FUNCTIONS (ADJUSTABLE PARAMETERS)				
Entry LED	Parameter	LED (level)	Set value	Description
L7	Maintenance notification	L1	500	Adjusts the number of manoeuvres after which the automation maintenance request is triggered (see the “ Maintenance notice ” function” paragraph).
		L2	1000	
		L3	1500	
		L4	2500	
		L5	5000	
		L6	10000	
		L7	15000	
		L8	20000	
L8	List of malfunctions	L1	Result of 1st manoeuvre (most recent)	Allows for verifying the type of anomaly that occurred in the last 8 manoeuvres (see “ Anomaly log ” paragraph).
		L2	Result of 2 nd manoeuvre	
		L3	Result of 3 rd manoeuvre	
		L4	Result of 4 th manoeuvre	
		L5	Result of 5 th manoeuvre	
		L6	Result of 6 th manoeuvre	
		L7	Result of 7 th manoeuvre	
		L8	Result of 8 th manoeuvre	

7.4 SPECIAL FUNCTIONS

7.4.1 “Move anyway” function

This function can be used to operate the automation even one or more some safety devices fail to work properly or are out of order. The automation can be controlled in “**hold-to-run**” mode by proceeding as follows:

1. send a command to operate the gate, using a transmitter or key selector, etc. If everything functions properly, the gate will move normally, otherwise proceed with point 2
2. within 3 seconds, press the control again and hold it down
3. after roughly 2 seconds, the gate will complete the requested manoeuvre in “**hold-to-run**” mode, in other words, it will continue to move so long as the control is held down.



When the safety devices fail to work, the warning light will emit a few flashes to signal the type of problem. To verify the type of anomaly, consult the “TROUBLESHOOTING... (troubleshooting guide)” chapter.

7.4.2 “Maintenance notice” function

This function allows for signalling to the user when the automation needs maintenance. The maintenance signal is given through a lamp connected to the “**OGI**” output, if this output is configured as a “**Maintenance indicator**”.

The configuration is only possible through the “Oview” programmer (refer to the “**Connecting the Oview programmer**” paragraph).



The various indicator lamp signals are shown in “Table 8”.

Table 8

“MAINTENANCE INDICATOR” SIGNAL	
Number of manoeuvres	Signal
Below 80% of the limit	Lamp stays lit for 2 seconds at the start of the opening manoeuvre.
Between 81% and 100% of the limit	Lamp flashes for the entire duration of the manoeuvre.
Over 100% of the limit	Lamp flashes continuously.

7.5 MEMORY DELETION



The procedure described below restores the control unit’s default settings. All the custom settings will be lost.

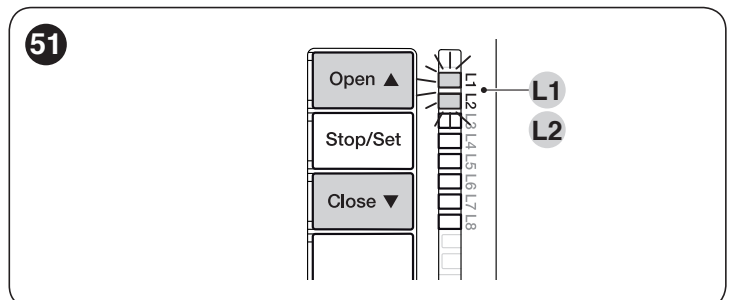

To delete the control unit’s memory and restore all the default settings, proceed as described below:

1. press and hold the [Open ▲] and [Close ▼] buttons until LEDs “L1” and “L2” start flashing
2. release the buttons.

Some devices are configured for signalling the operating status or the presence of any anomalies.

8.1 SIGNALLING THROUGH WARNING LIGHT

If a warning light is connected to the FLASH output (**A**) on the control unit, the light will flash once every 1 second while the manoeuvre is being performed.

If any anomalies occur, the warning light will emit shorter flashes which are repeated twice with a 1-second pause in between. “**Table 9**” describes the cause and possible solution for each type of anomaly signalled by the warning light.

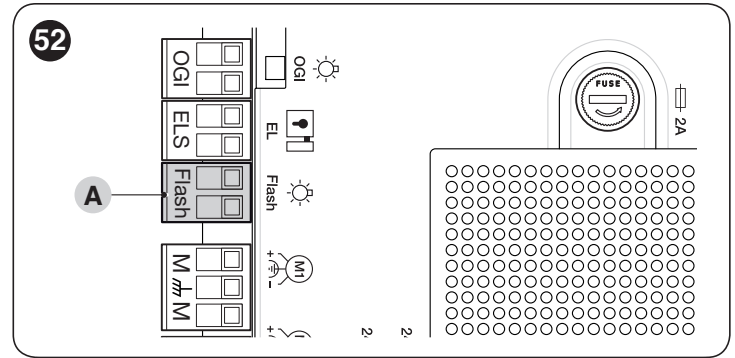

Table 9

SIGNALS OF THE WARNING LIGHT CONNECTED TO THE FLASH OUTPUT (“FIGURE 52”)		
Flashes	Anomaly	Possible solution
1 short red flash 1-second pause 1 short red flash	BlueBus system error	The check to verify the devices connected to the BlueBus system, run at the start of the manoeuvre, does not reveal the same devices memorised during learning phase. There may be some disconnected or faulty devices: check these and replace them if necessary. Some changes were made: the device learning procedure must be rerun.
2 short red flashes 1-second pause 2 short red flashes	Intervention of a photocell	One or more photocells do not consent to the movement or have caused the latter to reverse. Check for any obstacles.
3 short red flashes 1-second pause 3 short red flashes	Intervention of the “Obstacle Detection” function through the force limiter	During the gate’s movement, the motors encountered more resistance. Verify the cause and increase the motor force if necessary.
4 short red flashes 1-second pause 4 short red flashes	Intervention of the STOP input	At the start of the manoeuvre or during the movement itself, the devices connected to the STOP input intervened. Identify the cause.
5 short red flashes 1-second pause 5 short red flashes	Error in the internal parameters of the control unit	Wait at least 30 seconds then try giving a command and disconnect the power supply if necessary. If the condition persists, there may be a serious malfunction and the electronic board needs to be replaced.
6 short red flashes 1-second pause 6 short red flashes	The maximum limit for consecutive manoeuvres or manoeuvres per hour has been exceeded	Wait for a few minutes until the manoeuvre limiting device drops to under the maximum limit.
7 short red flashes 1-second pause 7 short red flashes	Electric circuit anomaly	Wait at least 30 seconds then try giving a command and disconnect the power supply if necessary. If the condition persists, there may be a serious malfunction and the electronic board needs to be replaced.
8 short red flashes 1-second pause 8 short red flashes	A command that prevents other commands from being executed is already present	Check the type of the “always present” command (for example, it could be a command from a clock on the AUX input).
9 short red flashes 1-second pause 9 short red flashes	The automation was stopped by a “Stop automation” command	Unlock the automation mechanism by giving the “Unlock automation” command.
10 short red flashes 1-second pause 10 short red flashes	Intervention of the “Obstacle Detection” function from the encoder	The motors were hampered by greater friction during their movement. Identify the cause.

8.2 SIGNALS ON THE CONTROL UNIT

The control unit has LEDs “L1-L8” on the buttons and LEDs “L9-L13” on the control unit terminals (“Figure 54”).

Each of these LEDs can emit special signals both during normal operation and in case on anomalies. “Table 10 and Table 11” describe the cause and possible solution for each type of anomaly.

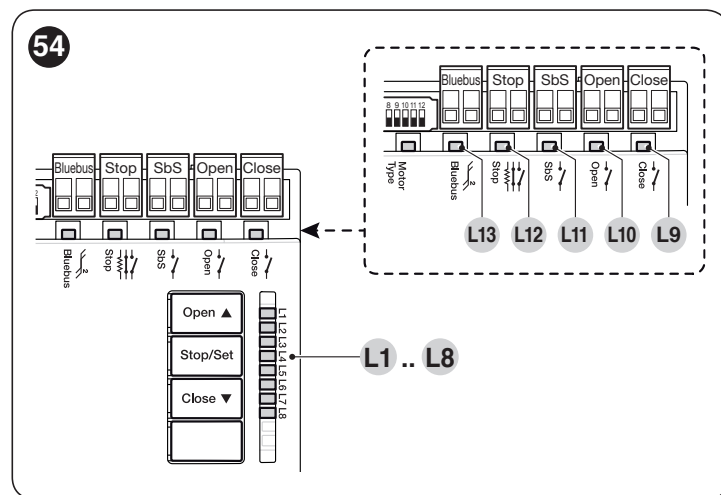
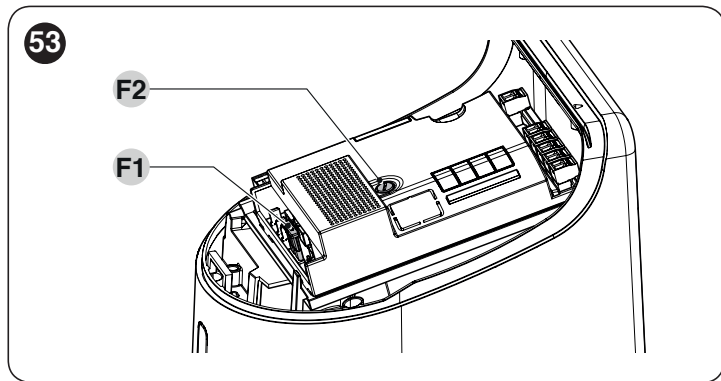

Table 10

SIGNALS OF THE LEDs ON THE CONTROL UNIT TERMINALS		
Status	Meaning	Possible solution
All LEDs		
No LED is lit	No power to the control unit	Check for the presence of power; check that the fuses are not blown; if necessary, identify the cause of the fault then replace them with fuses having the same specifications. If also the “BlueBus” LED is not lit or flashing, there probably is a serious fault that requires the control unit to be replaced.
BLUEBUS LED		
Green LED always off	Anomaly	Check for the presence of power; check that the fuses are not blown; if necessary, identify the cause of the fault then replace them with fuses having the same specifications.
Green LED always on	Serious anomaly	There is a serious problem: try disconnecting the power supply to the control unit and if the condition persists, replace the electronic board.
1 flash per second of the green LED	Everything normal	Normal control unit operation.
2 fast flashes of the green LED	Variation of the status of the inputs	This is normal if there is a change in one of the “SbS”, “Stop”, “Open” or “Close” inputs, the control photocells intervene or a command is transmitted with a transmitter.
Series of flashes of the red LED divided by a 1-second pause	Various	Refer to that shown in “Table 9”.
STOP LED		
OFF	Intervention of the “Stop” input	Check the devices connected to the “Stop” input.
On	All OK	“Stop” input active.
SbS LED		
OFF	All OK	“SbS” input not active.
On	Intervention of the “SbS” input	Normal if the device connected to the “SbS” input is active.
OPEN LED		
OFF	Everything normal	“Open” input not active.
On	Intervention of the “Open” input	This is normal if the device connected to the “Open” input is active.
CLOSE LED		
OFF	Everything normal	“Close” input not active.
On	Intervention of the “Close” input	This is normal if the device connected to the “Close” input is active.

SIGNALS OF LED (L1..L4) ("FIGURE 54")		
Status	Meaning	Possible solution
LEDs L1 - L2		
Slow flashing	Change in the number of devices connected to the "BlueBus" or learning of the device not executed.	It is necessary to run the device learning procedure (refer to the " Device learning " paragraph)
LEDs L3 - L4		
Slow flashing	The positions of the mechanical stops were never learned or after the mechanical stop learning procedure, the dip-switch configuration changed.	It is necessary to run the device learning procedure (refer to the " Device learning " paragraph)

8.3 ANOMALY LOG

The control unit can display any anomalies that have occurred in the last 8 manoeuvres (for example, the interruption of a manoeuvre due to the intervention of a photocell or sensitive edge).

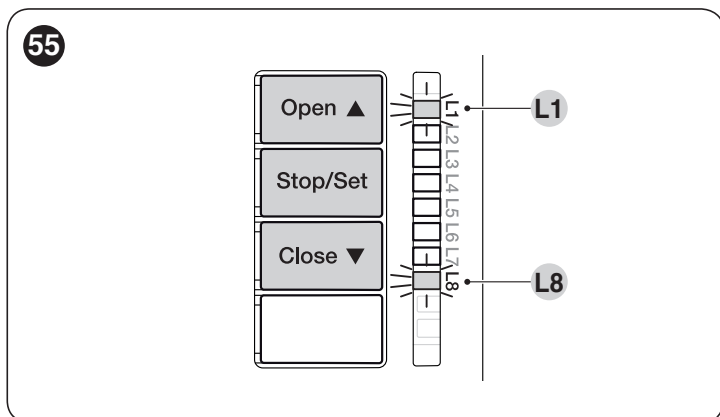

To check the list of anomalies:

1. press and hold the **[Stop/Set]** button for roughly 3 seconds
2. release the **[Stop/Set]** button when the "L1" LED starts flashing
3. press and release the **[Open ▲]** or **[Close ▼]** button to shift flashing of the LED to "L8" ("Anomaly list" parameter)
4. keep the **[Stop/Set]** button pressed down (it must be kept pressed throughout phases 5 and 6)
5. wait roughly 3 seconds, after which LED "L1" – corresponding to the outcome of the last manoeuvre – will light up
6. press and hold the **[Open ▲]** or **[Close ▼]** button to select the desired manoeuvre: the corresponding LED will emit the same number of flashes as those normally emitted by the warning light after an anomaly (see "**Table 9**")
7. release the **[Stop/Set]** button.

9 FURTHER INFORMATION (Accessories)

9.1 ADDING OR REMOVING DEVICES

Once the automation has been assembled, it is possible to add or remove devices at any time. In particular, various types of devices can be connected to the "BlueBUS" and "STOP" inputs, as described in the following paragraphs.



After having added or removed devices, these must be learned as described in the "Learning of other devices**" paragraph.**

9.1.1 BlueBUS

BlueBUS is a technique that allows for connecting compatible devices with only two wires which carry the electrical power and the communication signals. All devices are connected in parallel on the same 2 BlueBUS wires and without having to observe the polarities; each device is recognised because it is assigned a univocal address during the installation phase.

The following devices can be connected to the BlueBUS: photocells, safety devices, control buttons, signalling lights, etc. The control unit recognises all the connected devices individually through an appropriate learning phase, and can detect all possible anomalies with absolute precision.

For this reason, whenever a device is connected to or removed from BlueBUS, the learning phase must be carried out on the control unit, as described in the "**Learning of other devices**" paragraph.

9.1.2 STOP input

STOP is the input that causes immediate stoppage of the manoeuvre followed by its brief reversal. Devices with output featuring normally open "NO" and normally closed "NC" contacts, as well as devices with 8.2 kΩ fixed resistor output, such as sensitive edges, can be connected to this input.

As with the BlueBUS, the control unit recognises the type of device connected to the STOP input during the learning phase (see the "**Learning of other devices**" paragraph); subsequently the control unit gives a STOP command when it detects a variation with respect to the recognised status.

Multiple devices, even of different types, can be connected to the STOP input if suitable arrangements are made:

- Any number of NO devices can be connected to each other in parallel.
- Any number of NC devices can be connected to each other in series.
- Two devices with 8.2 kΩ fixed resistor output can be connected in parallel; if there are more than 2 devices then they must all be connected in cascade, with a single 8.2 kΩ terminating resistor.
- It is possible to combine two NO and NC contacts by placing them in parallel, while also mounting a 8.2 kΩ resistor in series with the NC contact (this also allows for combining 3 devices: NA, NC and 8.2 kΩ).

⚠ If the STOP input is used to connect devices with safety functions, only those devices with 8.2 kΩ fixed resistor guarantee Category 3 safety against faults in accordance with the EN 13849-1 standard.

9.1.3 Photocells

To allow the control unit to recognise the devices connected through the "BlueBUS" system, these devices must be addressed.

This operation can be carried out by correctly positioning the electrical jumper present in each device (also refer to the instruction manual of each device). Shown below is an addressing diagram for photocells, based on their type.

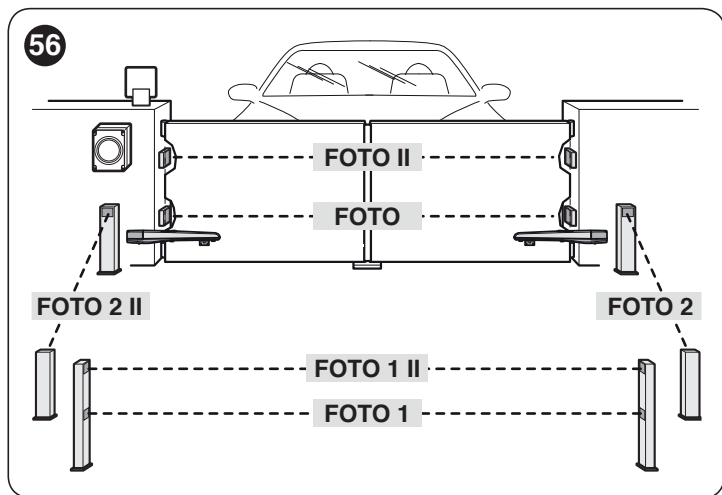

Table 12

PHOTOCELL ADDRESSES	
Photocell	Position of the jumpers
FOTO (PHOTO) External photocell h = 50 activated during the closing phase (stops and reverses the gate's movement)	
FOTO II (PHOTO II) External photocell h = 100 activated during the closing phase (stops and reverses the gate's movement)	

PHOTOCELL ADDRESSES	
Photocell	Position of the jumpers
FOTO 1 (PHOTO 1) Internal photocell h = 50 cm with activation both during closing (stops and reverses the movement) and during opening (stops and restarts when the photocell disengages)	
FOTO 1 II (PHOTO 1 II) Internal photocell h = 100 cm with activation both during closing (stops and reverses the movement) and during opening (stops and restarts when the photocell disengages)	
FOTO 2 (PHOTO 2) Internal photocell triggered during the opening phase (stops and reverses the gate's movement)	
FOTO 2 II (PHOTO 2 II) Internal photocell triggered during the opening phase (stops and reverses the gate's movement)	
FOTO 3 (PHOTO 3) CONFIGURATION NOT ALLOWED	

✋ At the end of the installation procedure, or after photocells or other devices have been removed, the learning procedure must be carried out (see paragraph "Device learning").

9.1.4 Learning of other devices

Normally the learning of devices connected to "BlueBUS" and the "STOP" input takes place during the installation stage; however, if new devices are added or old ones removed, the learning process can be redone.

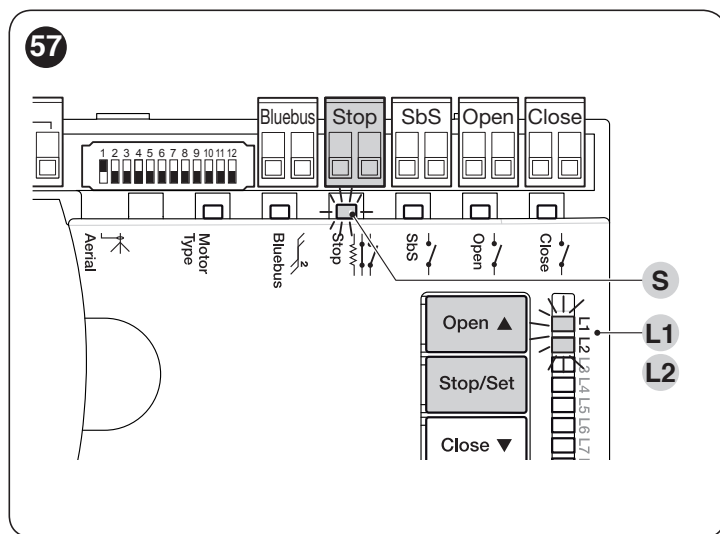

To do this:

1. simultaneously press and hold the **[Open ▲]** and **[Stop/Set]** buttons
2. release the buttons when LEDs "L1" and "L2" start flashing quickly (after roughly 3 seconds)
3. wait a few seconds until the control unit has completed the device learning phase
4. once this phase terminates, the "Stop" (S) LED must be lit and LEDs "L1" and "L2" must switch off (LEDs "L3" and "L4" could start flashing).

✋ After having added or removed devices, the automation test must be carried out again as specified in the "Testing" paragraph.

9.2 CONNECTING AN SM-TYPE RADIO RECEIVER

The control unit has a slot for mounting radio receivers with SM connector (optional accessories), which can be used to remotely control the control unit through transmitters that intervene on the unit's inputs.



Before installing a receiver, disconnect the power supply to the control unit.

To install a receiver ("Figure 58"):

1. remove the cover of the control unit's containment box
2. insert the receiver (**A**) in the appropriate slot (**B**) on the control unit's electronic board
3. put the cover of the control unit's containment box back on.

At this stage, the control unit can be powered again.

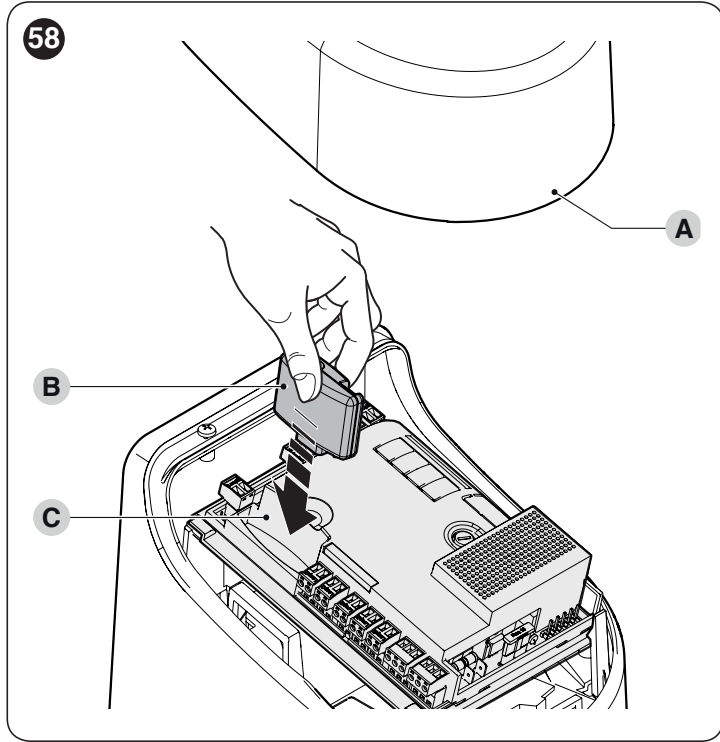

"Table 13" and "Table 14" show the "Receiver outputs" and the "Control unit inputs" associated with each.

Table 13

SMXI / SMXIS OR OXI / OXIFM / OXIT / OXITFM IN MODE 1 OR MODE 2	
Receiver output	Control unit input
Output No. 1	"SbS" (Step-by-Step) command
Output No. 2	"Partial opening 1" command
Output No. 3	"Open" command
Output No. 4	"Close" command

Table 14

OXI / OXIFM / OXIT / OXITFM IN MODE 2 EXTENDED		
No.	Command	Description
1	Step-by-Step	"SbS" (Step-by-Step) command
2	Partial opening 1	"Partial opening 1" command
3	Open	"Open" command
4	Close	"Close" command
5	Stop	Stops the manoeuvre
6	Condominium Step-by-Step	Command in condominium mode
7	High priority Step-by-Step	Commands also with the automation locked or the commands enabled
8	Partial open 2	Partial opening (the M2 gate leaf opens to 1/2 the full length)
9	Partial open 3	Partial open (the two gate leaves open to 1/2 the full length)
10	Opens and locks the automation	Triggers an opening manoeuvre and, once this terminates, locks the automation; the control unit will not accept any command other than "High priority Step-by-Step" and automation "Unlock", or (only from Oview) the following commands: "Unlock and close" and "Unlock and open"
11	Closes and locks the automation	Triggers a closing manoeuvre and, once this terminates, locks the automation; the control unit will not accept any command other than "High priority Step-by-Step" and automation "Unlock", or (only from Oview) the following commands: "Unlock and close" and "Unlock and open"
12	Lock automation	Triggers the stoppage of the manoeuvre and locks the automation; the control unit will not accept any command other than "High priority Step-by-Step" and automation "Unlock", or (only from Oview) the following commands: "Unlock and close" and "Unlock and open"
13	Release automation	Triggers unlocking of the automation and restores normal operation
14	On Timer Courtesy light	The courtesy light output switches on with timer-based switching off
15	On-Off Courtesy light	The courtesy light output switches on and off in Step-by-step mode



For further information, consult the specific manual of the receiver.

9.3 CONNECTING AND INSTALLING THE BACK-UP BATTERY



The electrical connection of the battery to the control unit must be made only after completing all the installation and programming stages, as the battery is an emergency power supply.



Before installing a back-up battery, disconnect the power supply to the control unit.

To install and connect the battery:

1. remove the cover (A)
2. lift the control unit (B) of the gearmotor
3. slide the battery (C) into its housing

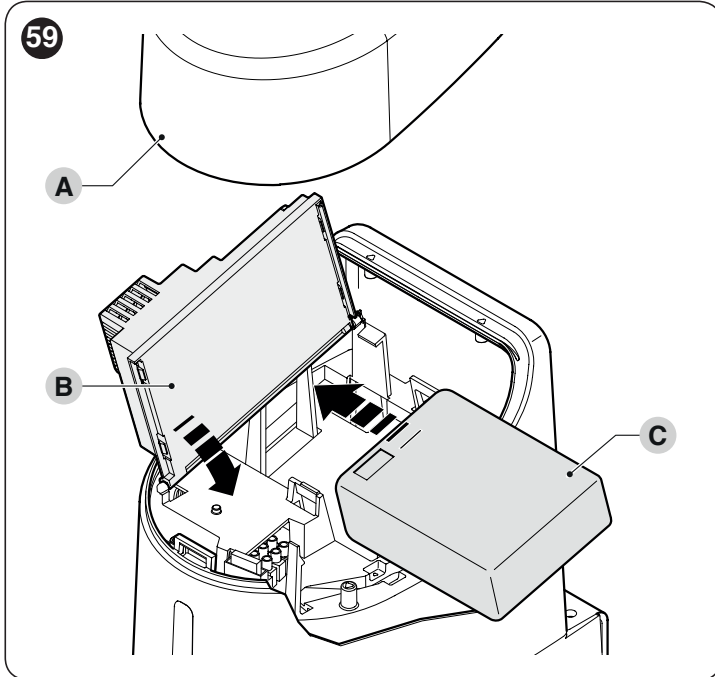

4. insert the relative connector (E) in the housing (A) on the control unit.

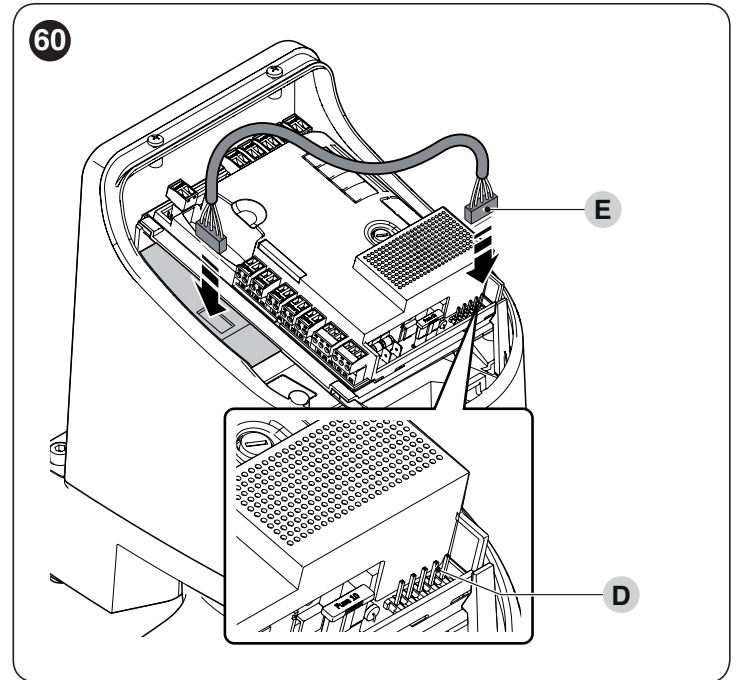

9.4 CONNECTING THE EXTERNAL UNLOCKING SYSTEM KIO



Kio must be connected to the garmotor that drives the leaf that starts moving first (when the gate is closed).

For the connection, proceed as follows:

1. remove the cover (A) and the plastic casing (B)

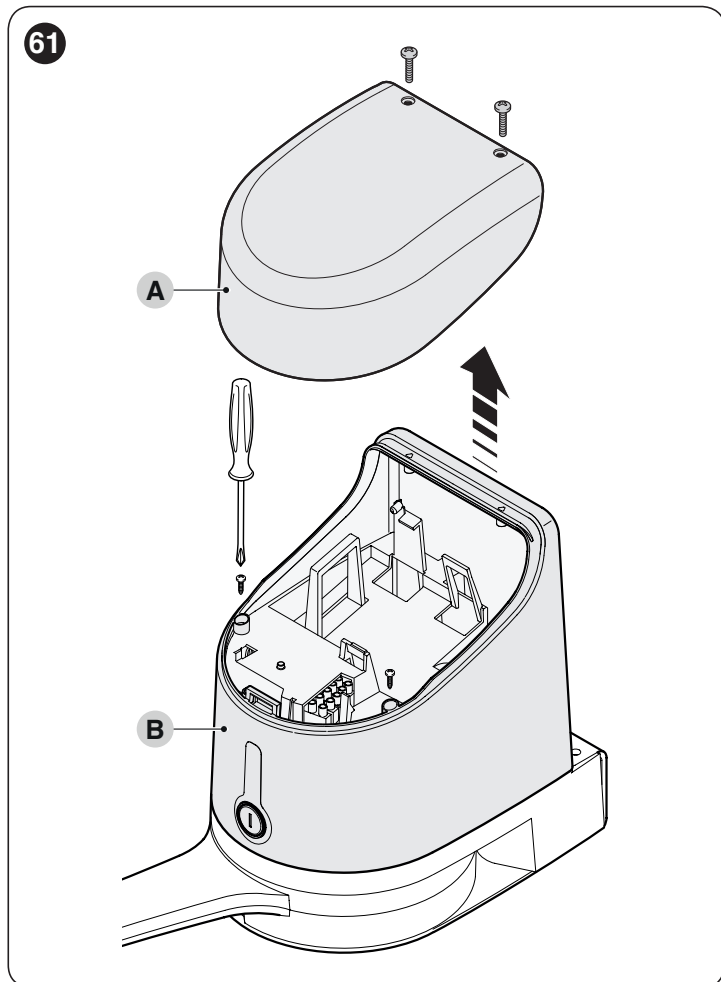

2. insert the pin (C) through the unlocking shaft hole

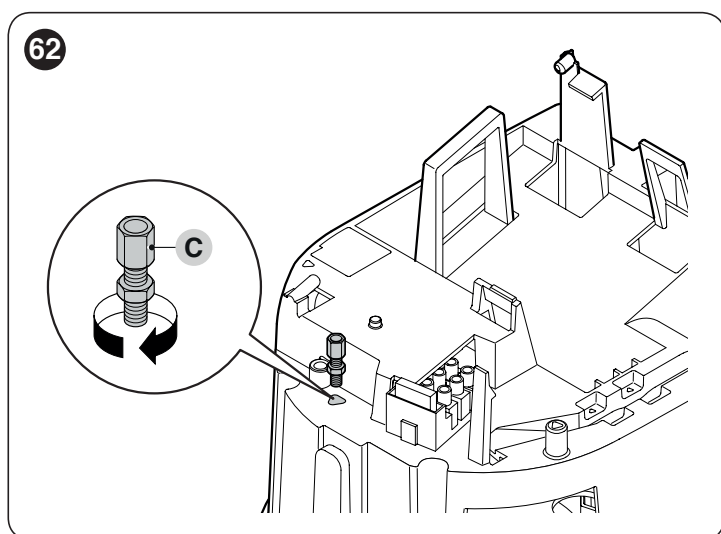

3. insert the steel cable (D) before the screw (C) and then through the hole of pin (E)
4. lock the cable in place by tightening the pin (F)

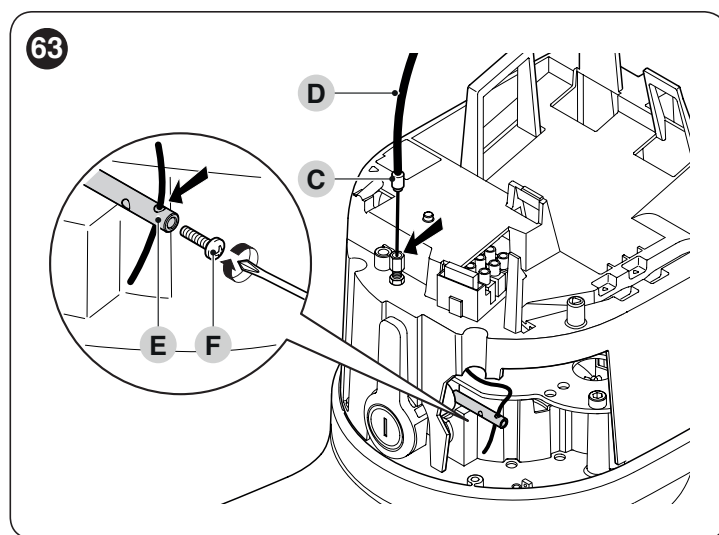

5. hook up the spring (G) by its two ends

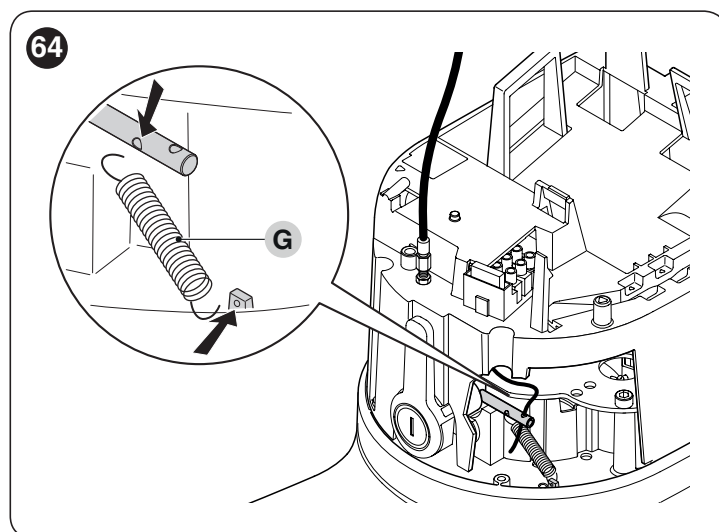

6. thread the other end of the cable through the hole located on the lower part of the garmotor

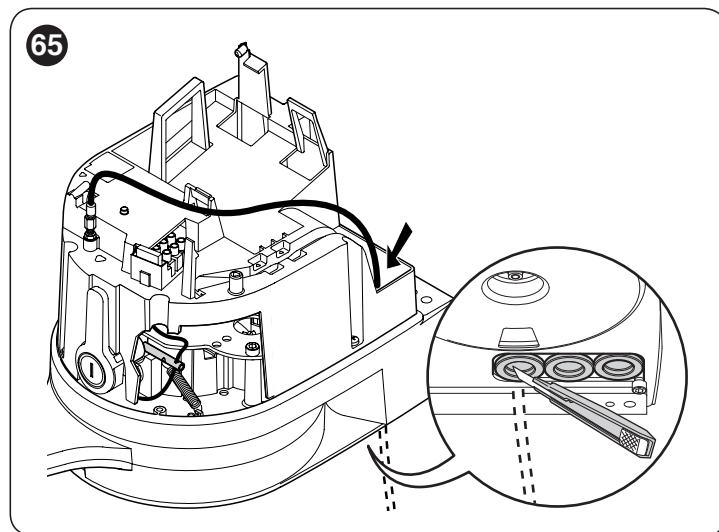

7. connect the cable to Kio, by referring to the respective instruction manual.

9.5 CONNECTING THE OVIEW PROGRAMMER

The "Oview" programming unit can be connected to the control unit.

This unit allows for rapidly and fully programming the functions, adjusting the parameters, updating the control unit firmware, running the diagnostics to detect any malfunctions and performing routine maintenance.

The "Oview" allows for operating on the control unit at a maximum distance of roughly 100 m. If several control units are networked with each other in a "BusT4" network, by connecting the "Oview" to one of these units, it is possible to view on the display all the networked control units (up to a maximum 16 units).

The "Oview" unit can also be left connected to the control unit during normal operation of the automation, so that the user can send commands using a specific menu.



Before connecting the IBT4N interface, it is necessary to disconnect the control unit from the power supply.

To install the interface:

1. remove the cover (A)
2. remove the plastic pre-cut element (B) and check that there are no burrs

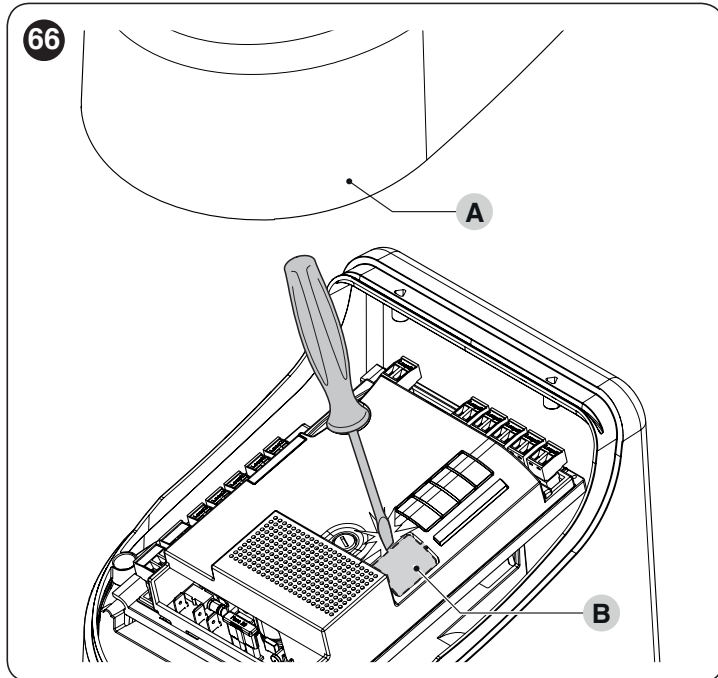

3. place the interface (C) in the appropriate slot (D) on the control unit's electronic board
4. insert the cable (E) in the appropriate slot (F) on the interface.

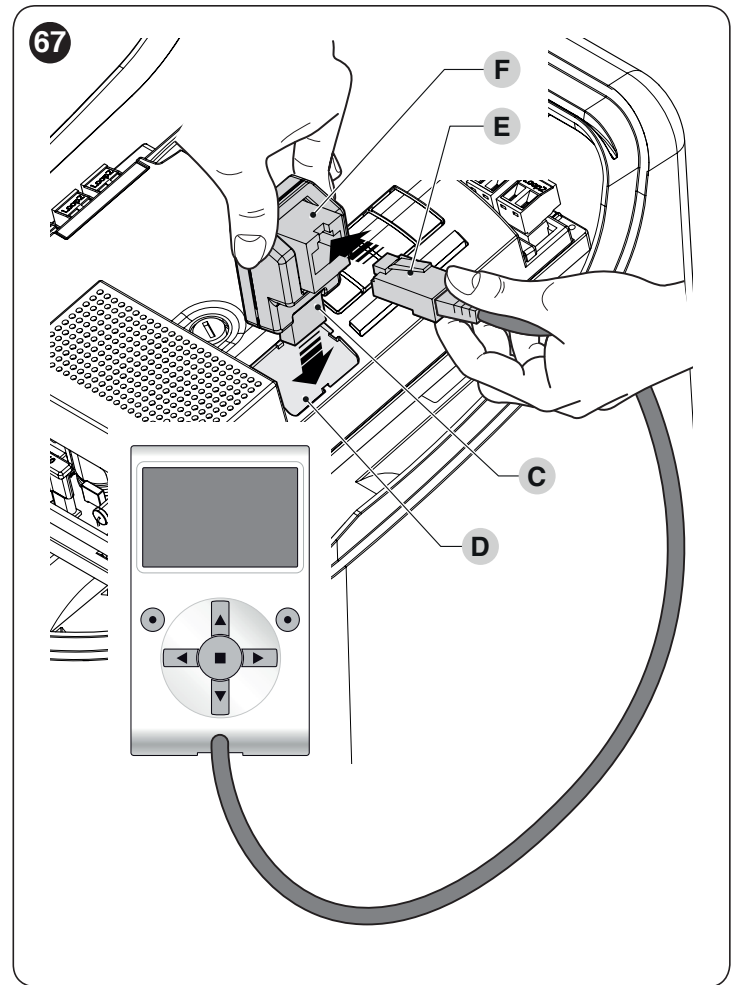

At this stage, the control unit can be powered again.



For further information, consult the specific manuals of the connected devices.

9.6 CONNECTING THE SOLEMYO SOLAR ENERGY SYSTEM



When the automation is powered by the “Solemyo” system, **IT MUST NOT BE POWERED** by the electricity grid at the same time.



For information on the “Solemyo” system, consult the relevant instruction manual.

To connect the “Solemyo” system:

1. remove the cover (A)
2. insert the relative connector (C) in the housing (B) on the control unit.

68

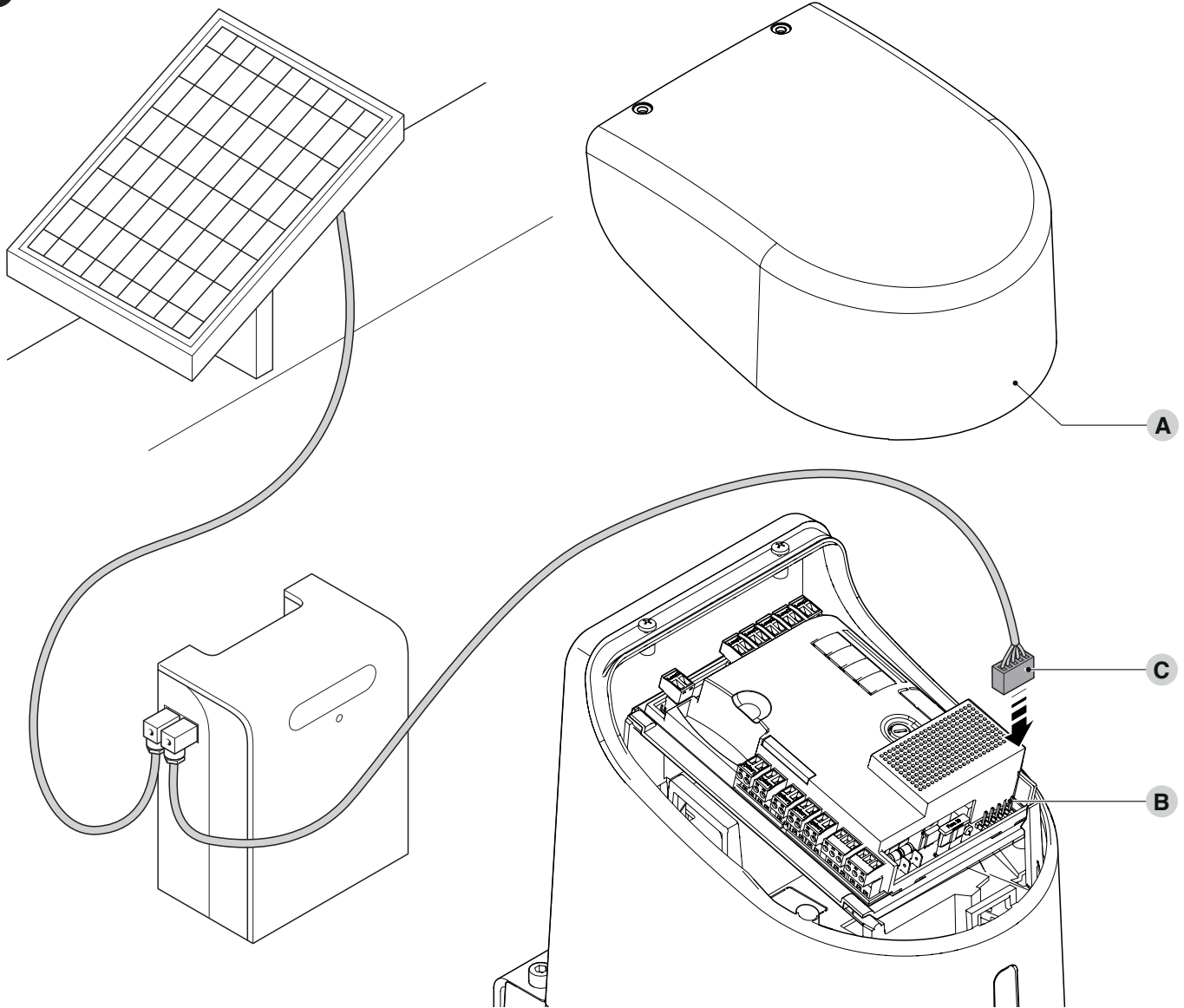

10 PRODUCT MAINTENANCE

The automation must be subjected to regular maintenance to keep its safety level constant and guarantee long-lasting operation; to this aim, **HYKE** has a manoeuvre counter and maintenance warning system; refer to the “**Maintenance notice**” **function**” paragraph.



Maintenance must be carried out strictly in compliance with the safety provisions provided in this manual and in accordance with the laws and regulations in force.

To carry out maintenance on the gearmotor:

1. Schedule maintenance interventions within maximum 6 months or after maximum 20.000 manoeuvres from the previous maintenance intervention
2. disconnect all power supplies, including any back-up batteries
3. check for any deterioration in the materials making up the automation, with special emphasis on erosion or oxidation of the structural parts; replace any parts that are not to standard
4. check the state of wear of moving parts: pinion, rack and all gate leaf components; replace any worn parts
5. connect the power supplies again and run all the tests and checks described in the “**Testing**” paragraph.

11 PRODUCT DISPOSAL



This product is an integral part of the operator and must therefore be disposed of with it.

As with the installation, only qualified personnel must dismantle the product at the end of its life.

This product is composed of different types of materials. Some of these materials can be recycled; others must be disposed of. Please enquire about the recycling or disposal systems in place in your local area for this type of product.



WARNING

Some parts of the product may contain polluting or dangerous substances. If not disposed of correctly, these substances may have a damaging effect on the environment and human health.



As indicated by the symbol shown here, this product must not be disposed of with household waste. Separate the waste for disposal and recycling, following the methods stipulated by local regulations, or return the product to the seller when purchasing a new product.

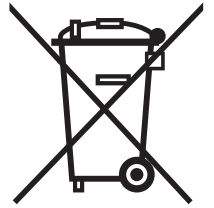

WARNING

Local regulations may impose heavy penalties if this product is not disposed of in compliance with the law.

12 TECHNICAL SPECIFICATIONS



All technical specifications stated in this section refer to an ambient temperature of 20°C (± 5°C). Nice S.p.A. reserves the right to apply modifications to the product at any time when deemed necessary, without altering its functions and intended use.

Table 15

TECHNICAL SPECIFICATIONS				
Description	Technical specification			
	HK7024	HK7224	HK7024HS	HK7224HS
Product type	Electromechanical gearmotor for automatic gate and door systems with direct-current motor, epicyclic gear reducer and mechanical unlocking mechanism. Incorporated control unit and OXI radio receiver		Electromechanical gearmotor for automatic gate and door systems with direct-current motor, epicyclic gear reducer and mechanical unlocking mechanism.	
Peak torque [corresponding to the ability to develop a force capable of moving the leaf]	500 Nm			
Nominal torque [corresponding to the ability to develop a force capable of keeping the leaf moving]	120 Nm			
No-load speed (the control unit allow for programming 6 speeds roughly equal to: 100, 85, 70, 55, 45, 30%)	1,5 rpm	2 rpm	1,5 rpm	2 rpm
Maximum frequency of operating cycles (at nominal torque)*	40 cycles/hour			
Maximum continuous operating time (at nominal torque)**	7 minutes			
Application limits	The product can be used on gates with leaves weighing up to 330 kg or for lengths up to 3,5 m	The product can be used on gates with leaves weighing up to 270 kg or for lengths up to 3 m	The product can be used on gates with leaves weighing up to 330 kg or for lengths up to 3,5 m	The product can be used on gates with leaves weighing up to 270 kg or for lengths up to 3 m
Durability	Estimated between 150.000 cycles and 500.000 cycles, depending on the conditions specified in the " Product durability " paragraph.			
Power supply HYKE	230V~ (±10%) 50/60 Hz		24V= (±10%)	
Emergency power supply	With optional accessory PS124		-	
Solar panel power supply	Configuration for SYKCE kit		-	
Maximum power draw at nominal torque	300 W		140 W	
Maximum current draw	1,5 A (3 A for version HK7024K/V1)		6 A for maximum 2 s	
Power draw in "Stand-by-All" mode with power supply from PS124 or SYKCE kit (including OXI receiver)	Below 30 mW		-	
Warning light output***	One LUCYB warning light (12 V=, 21 W) lamp		-	
Electric lock output***	One 12 V~ max 15 VA electric lock		-	
Gate open indicator output***	One 24 V lamp maximum 4 W (the output voltage can vary between -30 and +50%, the output can also control small relays)		-	
BLUEBUS output	One output with maximum load of 15 Bluebus units (maximum 6 pairs of photocells, e.g. EPMB or EPLB, plus 2 pairs of photocells addressed as opening devices plus maximum 4 EDSB or ETPB control devices)		-	

TECHNICAL SPECIFICATIONS				
Description	Technical specification			
	HK7024	HK7224	HK7024HS	HK7224HS
STOP input	For normally closed or normally open contacts or for 8.2 kΩ fixed resistor contacts with self-learning (any variation from the memorised status triggers the STOP command)		-	
Sbs input	For normally open contacts (closing of the contact triggers the STEP-BY-STEP command)		-	
OPEN input	For normally open contacts (closing of the contact triggers the OPEN command)		-	
CLOSE input	For normally open contacts (closing of the contact triggers the CLOSE command)		-	
Radio connector	SM connector for SMXI, OXI and OXIFM receivers		-	
Radio ANTENNA input	50 Ω for RG58-type cable or similar		-	
Programmable functions	8 ON-OFF functions and 8 adjustable functions (see " Level 1 programming (ON-OFF) " paragraph)		-	
Self-learning functions	Self-learning of the devices connected to the BlueBus output Self-learning of the type of "STOP" device (Normally Open, Normally Closed contact or 8.2 kΩ resistor) Self-learning of the gate path and automatic calculation of the slowdown and partial opening points. Self-learning of the operation with one or two motors.		-	
Assembly	Vertical, with a dedicated fixing plate			
Operating temperature	-20°C ÷ 55°C(at low temperatures, the gearmotor's efficiency decreases)			
Use in highly acid, saline or potentially explosive atmosphere	NO			
Protection rating	IP 54 (with container intact)			
Dimensions (mm)	210x290xh230h			
Weight (kg)	10,5 kg		9,5 kg	

* Frequency of cycles at the maximum temperature: 25 cycles/hour

** Maximum continuous cycle time at the maximum temperature: 8 minutes

*** The "Warning light" and "Electric lock" outputs can be programmed with other functions (see paragraph "**Level 1 programming (ON-OFF)**"), or paragraph "**Connecting the Oview programmer**"). The electrical characteristics of the outputs can be adapted on the basis of the type of chosen function: warning light function: 12 V $\overline{=}$, 21 W max lamp; electric lock function: 12 V \sim , 15 VA max; other outputs (all types): 1 lamp or relay 24 V $\overline{=}$ (-30 e +50%), 4 W max.

EU Declaration of Conformity**and declaration of incorporation of "partly completed machinery"**

Note - The contents of this declaration correspond to declarations in the official document deposited at the registered offices of Nice S.p.a. and in particular to the last revision available before printing this manual. The text herein has been re-edited for editorial purposes. A copy of the original declaration can be requested from Nice S.p.a. (TV) I.

Number: 334/HYKE**Rev:** 4**Language:** EN**Manufacturer's Name:**

Nice s.p.a.

Address:

Via Callalta 1, 31046 Oderzo (TV) Italy

Authorized Person to constitute**technical documentation:**

Nice s.p.a.

Type of product:

Electromechanical gear motor "HYKE" with incorporated control unit

Model/Type:

HK7024, HK7224, HK7024HS, HK7224HS

Accessories:

Refer to the catalog

The undersigned Roberto Griffa, in the role of Chief Executive Officer, declares under his sole responsibility that the product described above complies with the provisions laid down in the following directives:

- Directive 2014/30/EU (EMC), according to the following harmonized standards: EN 61000-6-2:2005, EN 61000-6-3:2007+A1:2011

The product also complies with the following directives according to the requirements envisaged for "partly completed machinery" (Annex II, part 1, section B):

- Directive 2006/42/EC of the EUROPEAN PARLIAMENT AND COUNCIL of 17 May 2006 related to machinery and amending the Directive 95/16/EC (recast).

It is hereby stated that the relevant technical documentation has been compiled in accordance with annex VII B of Directive 2006/42/EC and that the following essential requirements have been fulfilled: 1.1.1 - 1.1.2 - 1.1.3 - 1.2.1 - 1.2.6 - 1.5.1 - 1.5.2 - 1.5.5 - 1.5.6 - 1.5.7 - 1.5.8 - 1.5.10 - 1.5.11

The manufacturer undertakes to transmit to the national authorities, in response to a reasoned request, the relevant information on the "partly completed machinery", while maintaining full rights to the related intellectual property.

Should the "partly completed machinery" be put into service in a European country with an official language other than that used in this declaration, the importer is obliged to arrange for the relative translation to accompany this declaration.

The "partly completed machinery" must not be used until the final machine in which it is incorporated is in turn declared as compliant, if applicable, with the provisions of directive 2006/42/EC.

The product also complies with the following standards:

EN 60335-1:2012+A11:2014, EN 62233:2008, EN 60335-2-103:2015

Oderzo, 05/09/2017

NOTES

A series of horizontal dashed lines for writing notes.

Before using the automation for the first time, ask the installer to explain the origin of any residual risks and take a few minutes to read this instruction manual and warnings for the user given to you by the installer. Store the manual for future reference and hand it to the new owner when transferring the automation.



WARNING!

Your automation is a machine that faithfully executes commands imparted by the user. Negligence and improper use may lead to dangerous situations:

- do not manoeuvre the gate if there are people, animals or objects within its range of operation
- it is strictly forbidden to touch parts of the automation while the gate or door is moving
- the photocells are not a safety device but only an auxiliary aid to safety. They are built using highly reliable technology but, in extreme conditions, may malfunction or even become defective. In certain cases, the defect may not be clearly evident. For these reasons, it is important to follow all the instructions given in this manual when using the automation
- periodically check that the photocells work properly.



IT IS STRICTLY FORBIDDEN to transit through the gate while it is closing! It is only possible to transit through the gate when it is fully open and the leaves are at a standstill.



CHILDREN

An automation system guarantees a high degree of safety. With its detection systems, it can control and guarantee the gate's movement in the presence of people or objects. It is nonetheless advisable to forbid children from playing near the automation and not to leave remote controls near them to prevent any unwanted activation of the system. The automation is not a toy!

The product is not intended for use by persons, including children, with limited physical, sensory or mental capacities, or who lack experience or knowledge, unless supervised or trained in the use of the product by a person responsible for their safety.

Anomalies: if the automation shows any signs of anomalous behaviour, disconnect the power supply to the system and manually unlock the motor (see instructions at the end of the chapter) to manoeuvre the gate manually. Do not attempt any repairs personally but contact your trusted installer.



Do not modify the system or the programming and adjustment parameters of the control unit: your installer is exclusively responsible for these operations.

Failure or lack of power supply: while waiting for the installer to intervene or the electricity to be restored, if the system is not equipped with back-up batteries, the automation can nonetheless be used by manually unlocking the motor (consult the instructions at the end of the chapter) and moving the gate leaf manually.

Safety devices out of order: the automation can also be used when one or more safety devices are defective or out of order. The gate can be operated in the "hold-to-run" mode in the following way:

1. send a command to operate the gate using a transmitter or key selector, etc. If everything works normally, the gate will move regularly, otherwise the warning light will flash a few times and the manoeuvre will not start (the number of flashes depends on the reason for which the manoeuvre cannot start)
2. in this case, within 3 seconds press the control again and hold it down
3. after roughly 2 seconds, the gate will complete the requested manoeuvre in "Hold-to-run" mode, in other words, it will continue to move so long as the control is held down.



If the safety devices are out of order, have the system repaired as soon as possible by a qualified technician.

The test, periodic maintenance and any repairs must be documented by the person carrying out the work and the documents must be stored by the owner of the automation. The only interventions the user may carry out periodically include cleaning of the photocell glass components (use a soft and slightly damp cloth) and removing any leaves or stones that may obstruct the automation.



Before carrying out any maintenance operations, the user of the automation must manually unlock the motor to prevent anyone from accidentally triggering the gate's movement (consult the instructions at the end of the chapter).

Maintenance: in order to ensure constant levels of safety and the longest useful life for the automation, routine maintenance must be carried out (at least every 6 months).



Only qualified personnel is authorised to carry out checks, maintenance operations and repairs.

Disposal: at the end of its useful life, the automation must be dismantled by qualified personnel and the materials must be recycled or disposed of in compliance with the local regulations in force.

Replacing the remote control battery: if your remote control appears to be working poorly after some time, or stops working altogether, it may simply depend on flat batteries (depending on how much the device is used, the batteries may last from several months to over a year). You will notice this by the fact that the indicator light signalling the transmission fails to light up, is weak or lights up only for a short time. Before contacting the installer, try replacing the battery with that of another transmitter that works properly: if the anomaly is resolved, simply replace the flat battery with one of the same type.

Unlocking and manual movement

! The gate can only be unlocked once the leaf has come to a standstill.

To unlock the device:

1. insert the key **(A)** and turn it clockwise by 90°
2. turn the lever **(B)** by 90° anti-clockwise which, by effect of a spring, has come out of its housing

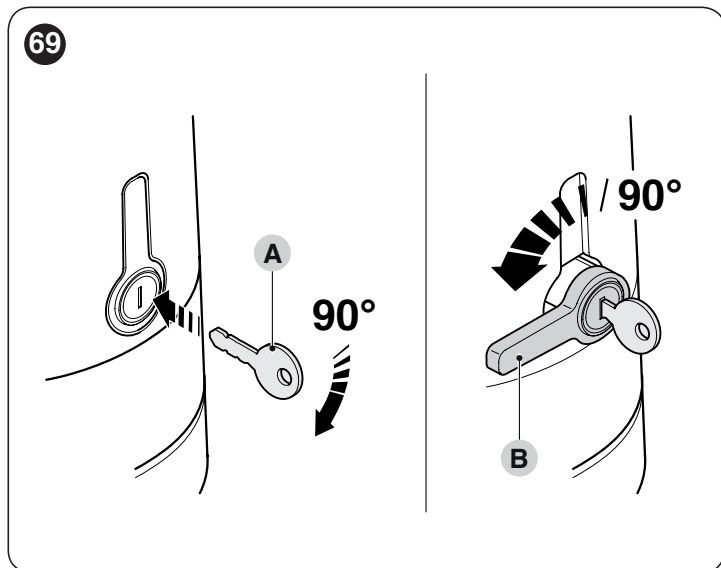

3. the gate leaf can now be moved manually to the desired position.

To lock the device:

1. turn the lever **(B)** by 90° until it lies in the vertical position
2. push the lever until it slots into its housing
3. turn the key **(A)** by 90° anti-clockwise
4. remove the key.

NOTES

A series of horizontal dashed lines for writing notes.



Nice SpA
Via Callalta, 1
31046 Oderzo TV Italy
info@niceforyou.com

www.niceforyou.com

IDV0670A00EN_01-10-2018