



DEIMOS BTA

FW ≥ 3.03

1 Cable run



Use normalised black cables R02V - H05VVF

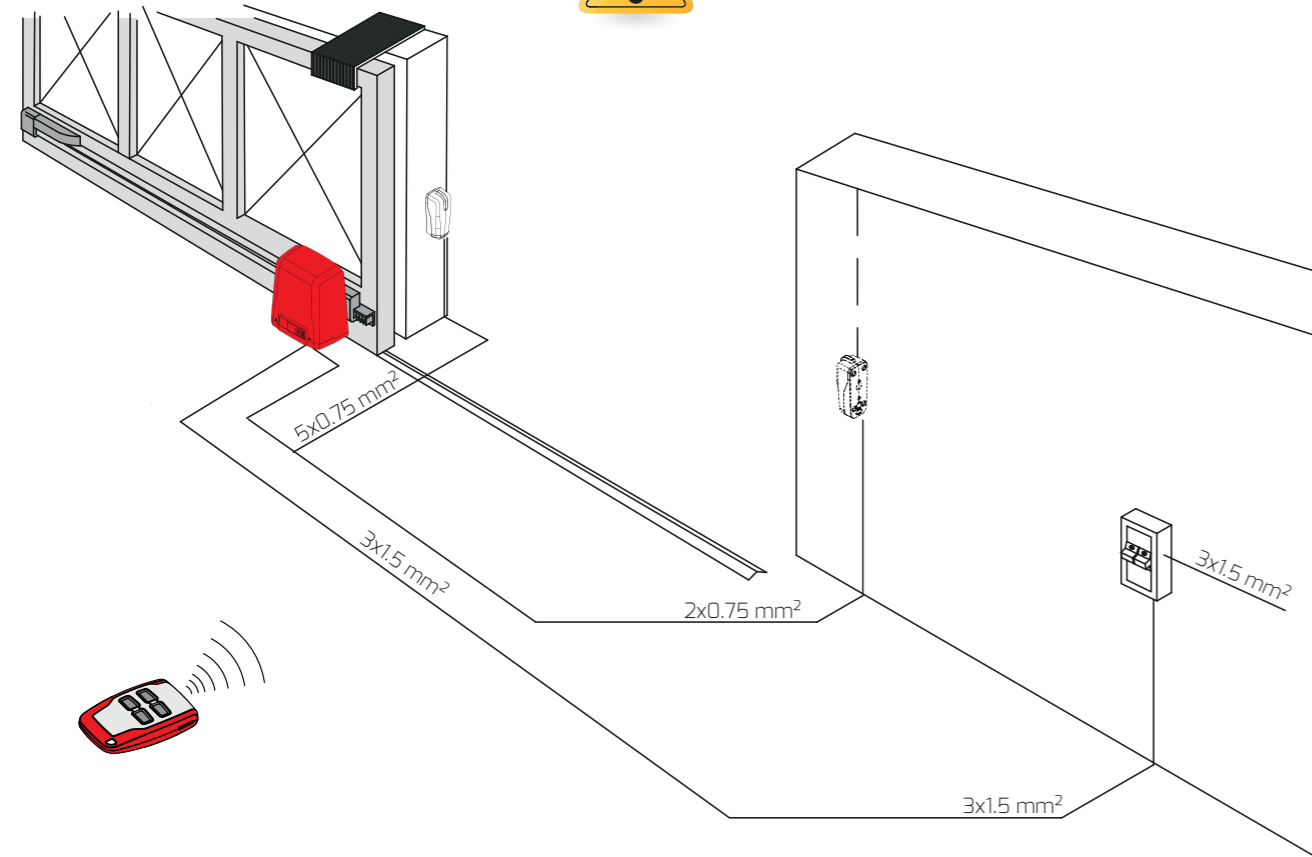

2 Motor fastening

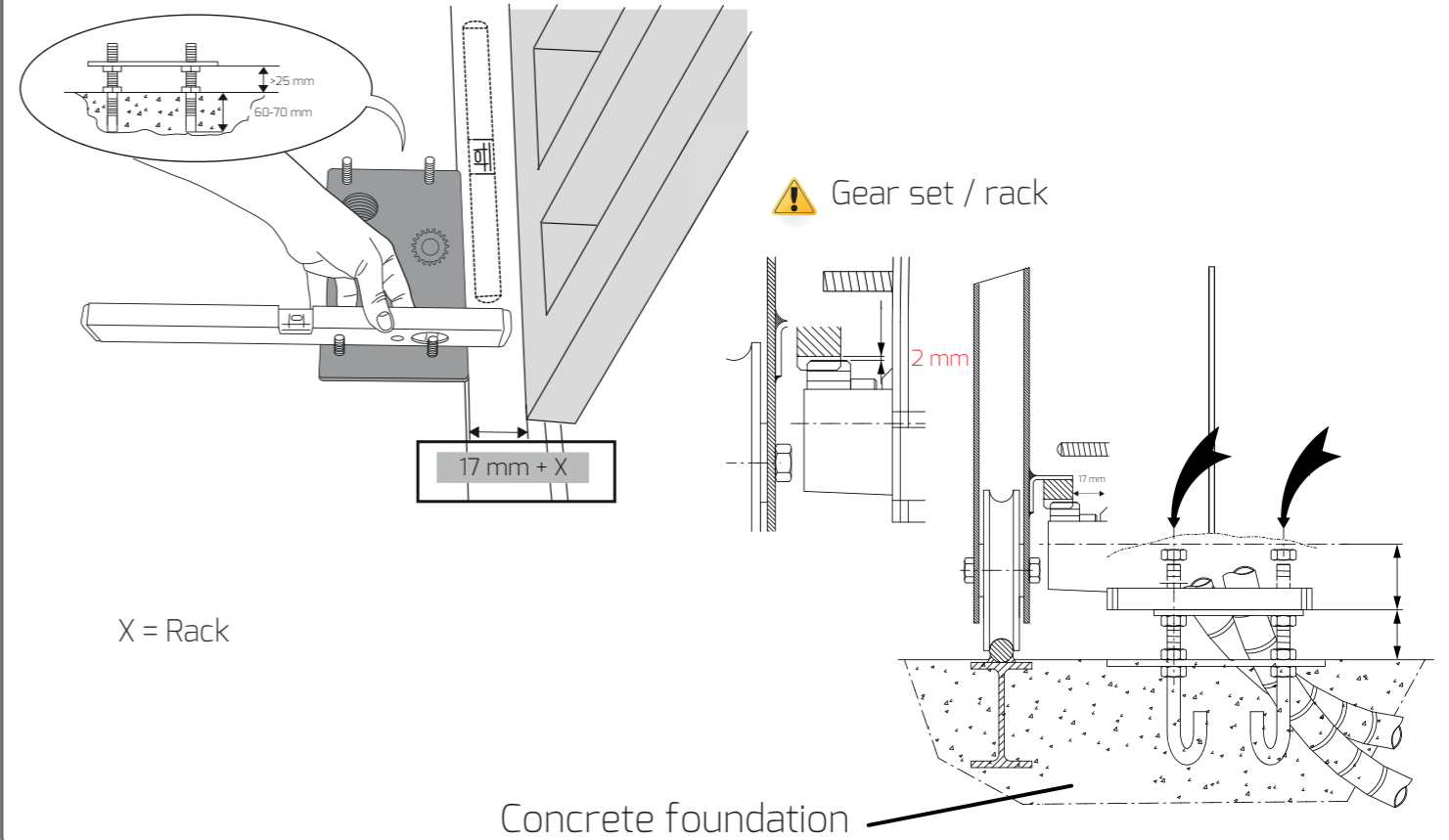

X = Rack

Concrete foundation

3 Limit switch adjustment

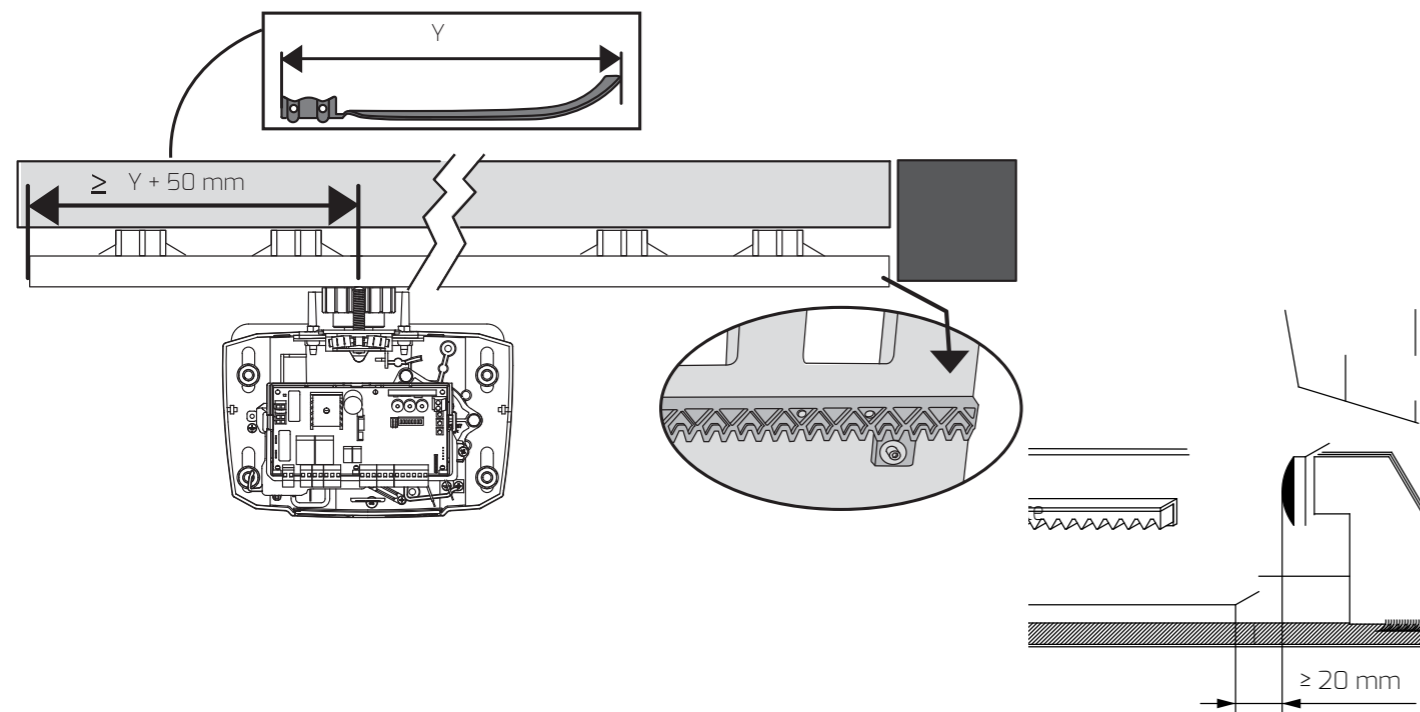

Position the feet at the limit switches while keeping a 2 cm margin before the gate stop. The limit switch pawl should be all down. Note: the first trigger pulse after switching on power is the opening.

4 Programming (see reverse)

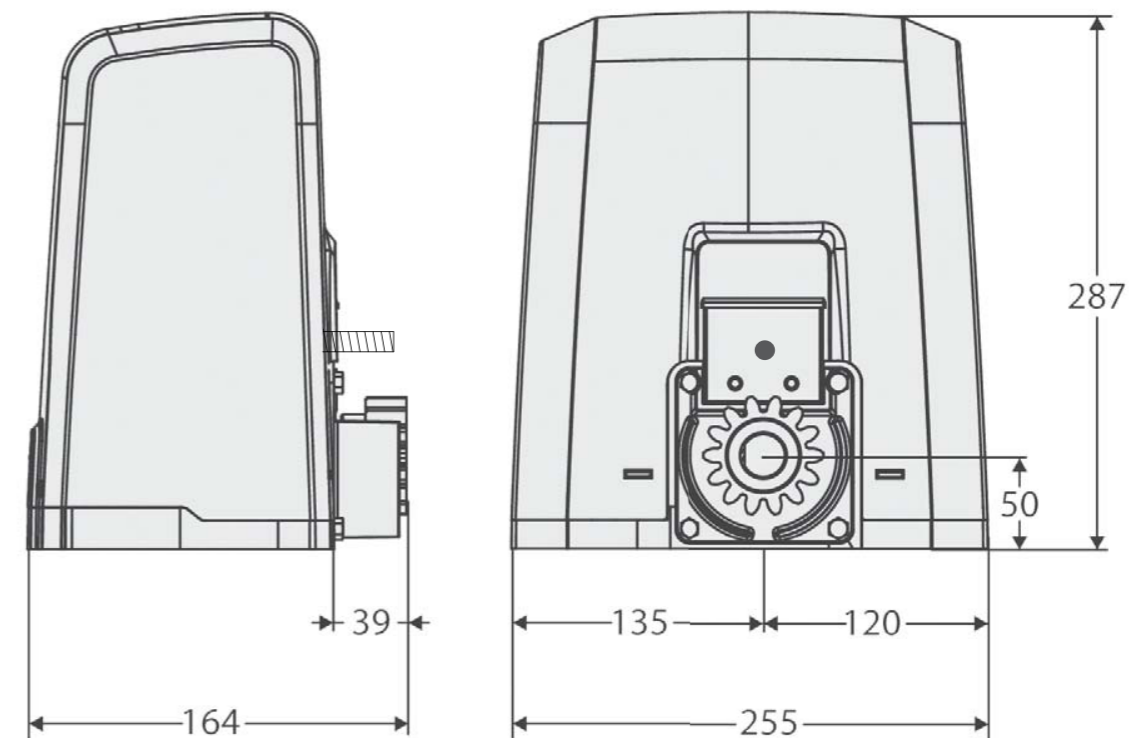

Hamal control board

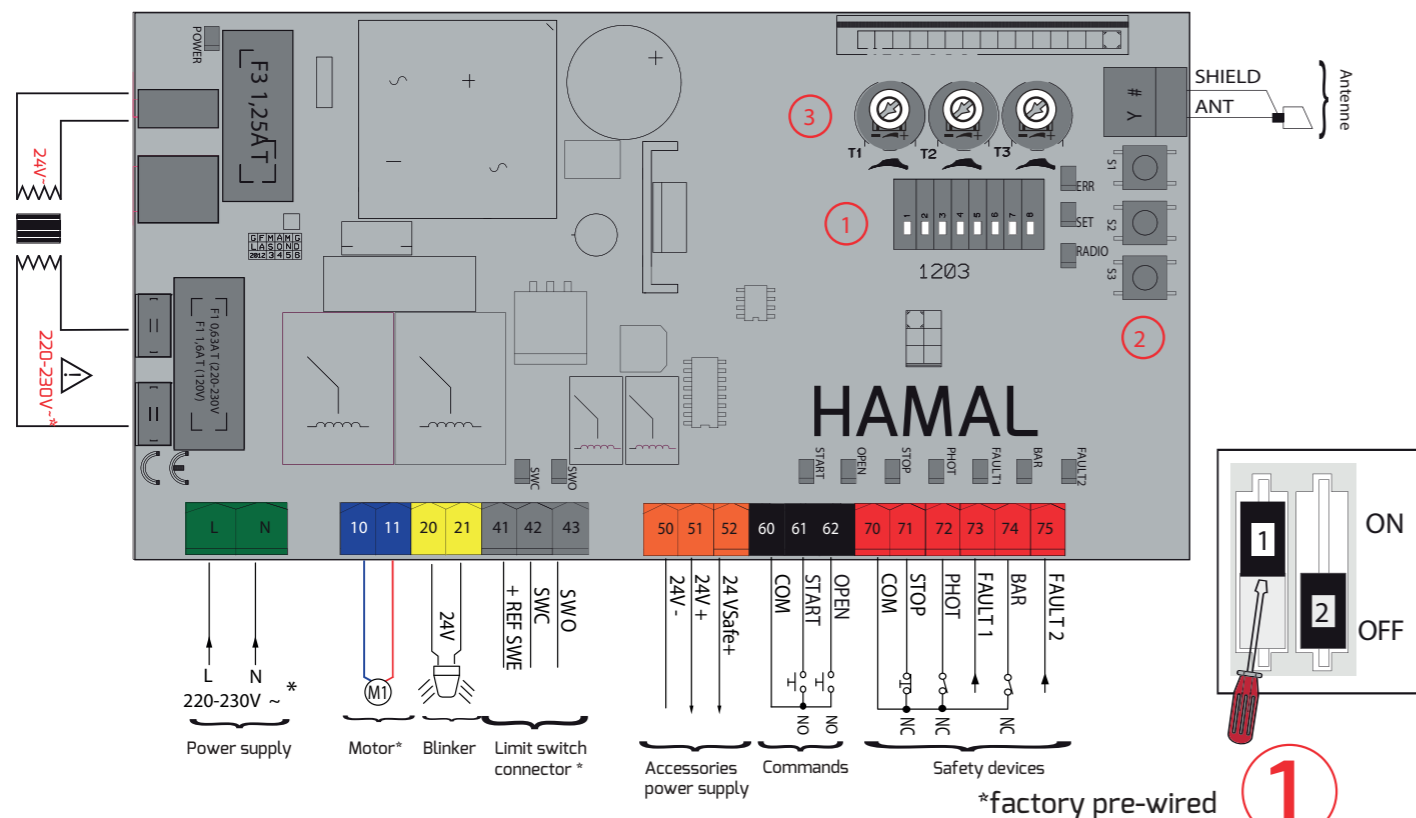

DIP	Function	
1	Transmitter programming	ON: Memorise the commands OFF: Disables memorizing of transmitters
2	Selection of sensing bars.	ON: Input for resistive edge 8K2. OFF: Entry for sensitive lintel.
3	Check photocells.	ON: Enable safety check OFF: Deactivate the check.
4	Secure entry check.	ON: Enable safety check OFF: Deactivate the check.
5	Photocells during closing	ON: Invert the movement during the closure phase only. OFF: Active on opening and closing; invert the movement during the closure phase.
6	Safety edge input operation	ON: Safety edge with active reversal only when closing, when opening the movement stops OFF: Safety edge with active reversal in both directions
7	Fast closure.	ON: Closes 3 seconds after the photocells are cleared OFF: Fast closure deactivated.
8	Residential / apartment building operation	Sets the automation type of operation: ON = Apartment building OFF = Residential

KEYS	Description
S1	Add Start Key associates the desired key with the Start command.
S2	Add Pedestrian Key associates the desired key with the pedestrian command.
S2 > 5s	Confirms the changes made to parameter settings and operating
S1+S2 > 10s	Erase List WARNING! Erases all memorized transmitters from the receiver's memory.
S3	Pressed BRIEFLY, it gives the START command. HELD DOWN (>5 sec.), it activates the AUTOSSET function.

*factory pre-parameterised

TRIMMER	Function	mini	maxi
T1	Waiting time before automatic closing.	0	120
T2	% Force exerted by leaf	10	90
T3	% Slow-down speed	5	50

Reaction to the START input (wired or radio):

	Residential	Apartment building
CLOSED	Opens	Opens
WHILE CLOSING	Stops	Opens
OPEN	Closes	Closes
WHILE OPENING	STOPS+TCA	No effect
AFTER STOP	Opens	Opens

Reaction to the OPEN input (wired):

	Residential	Apartment building
CLOSED	Opens	Opens
WHILE CLOSING	Opens	Opens
OPEN	No effect	No effect
WHILE OPENING	Keeps it open	Keeps it open
AFTER STOP	Opens	Opens

Reaction to the PEDESTRIAN input (radio):

	Residential	Apartment building
CLOSED	Opens partially	Opens partially
WHILE CLOSING	Stops	Opens partially
OPEN	Closes	Closes
WHILE OPENING	STOPS+TCA	No effect
AFTER STOP	Opens partially	Opens partially

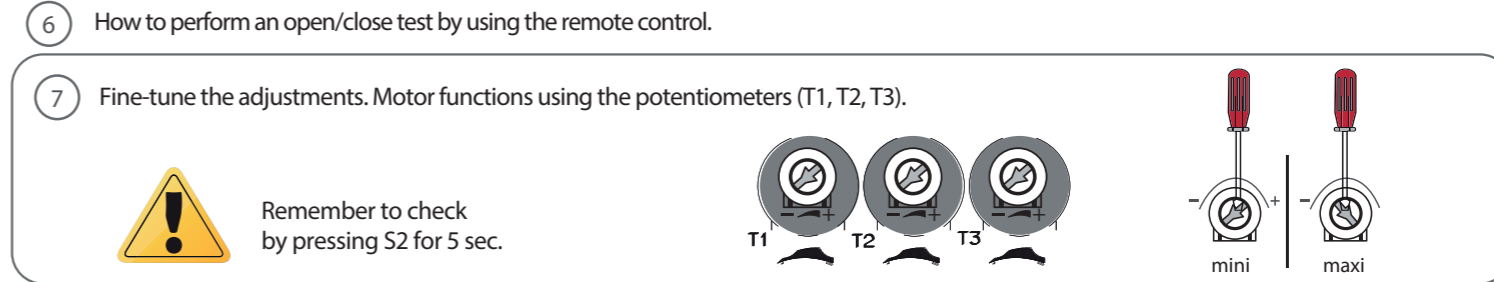
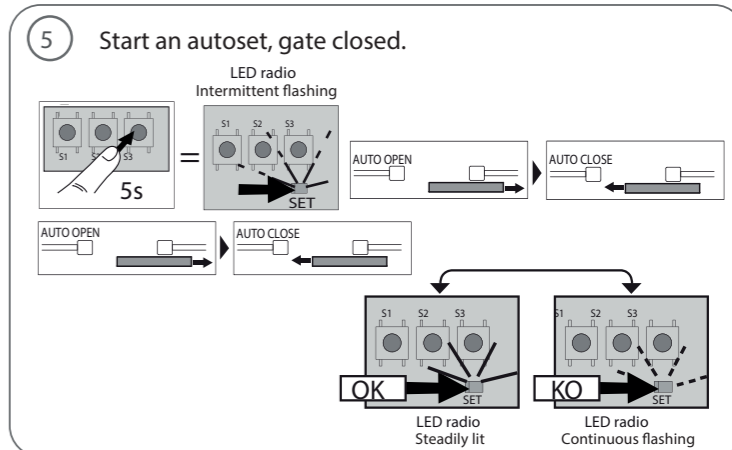
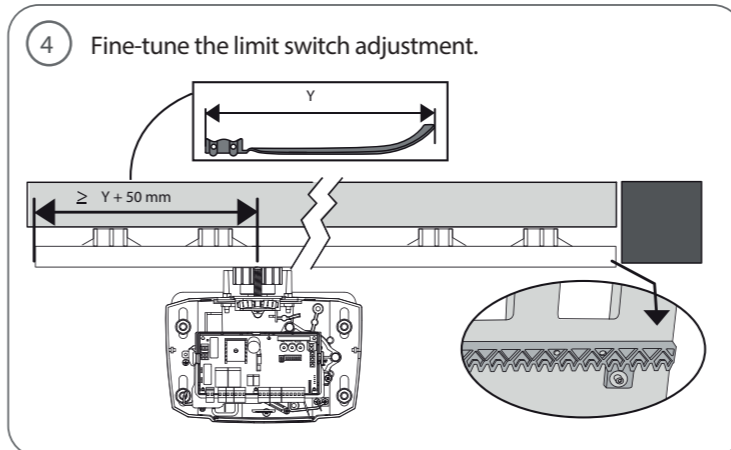
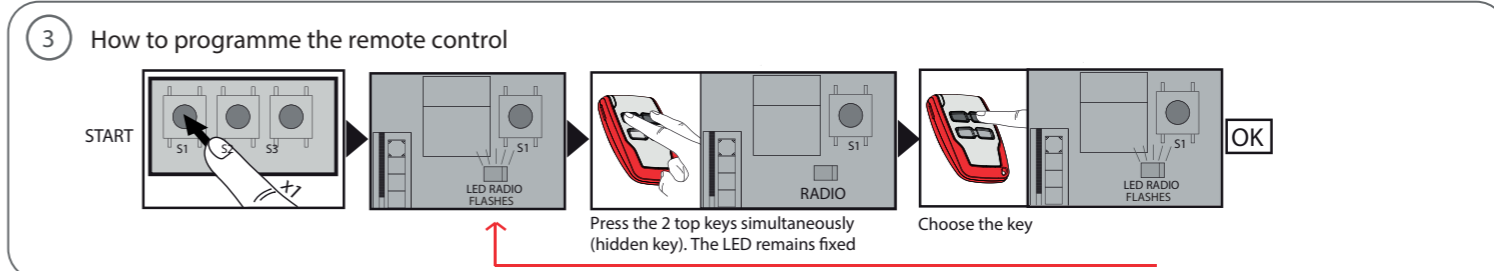
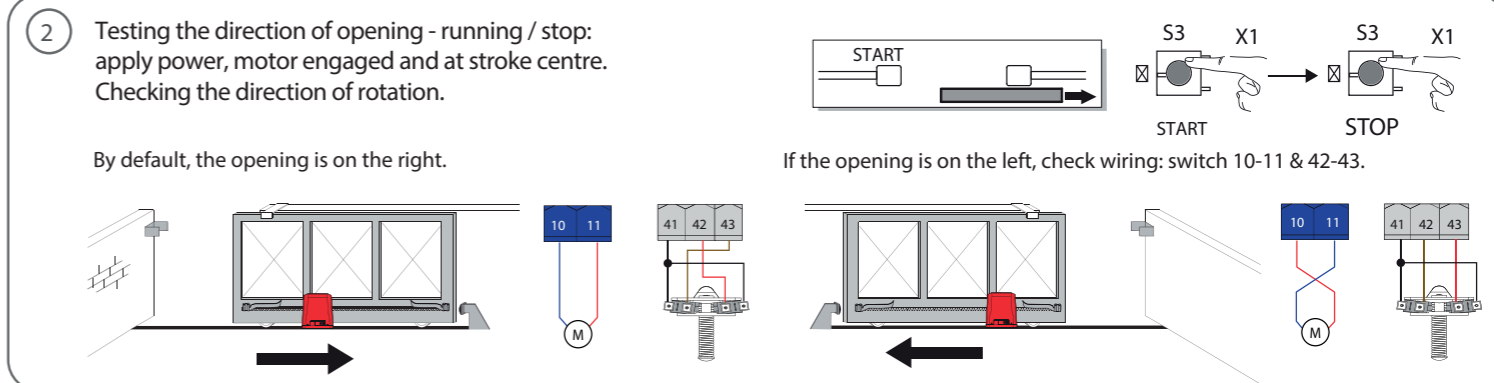
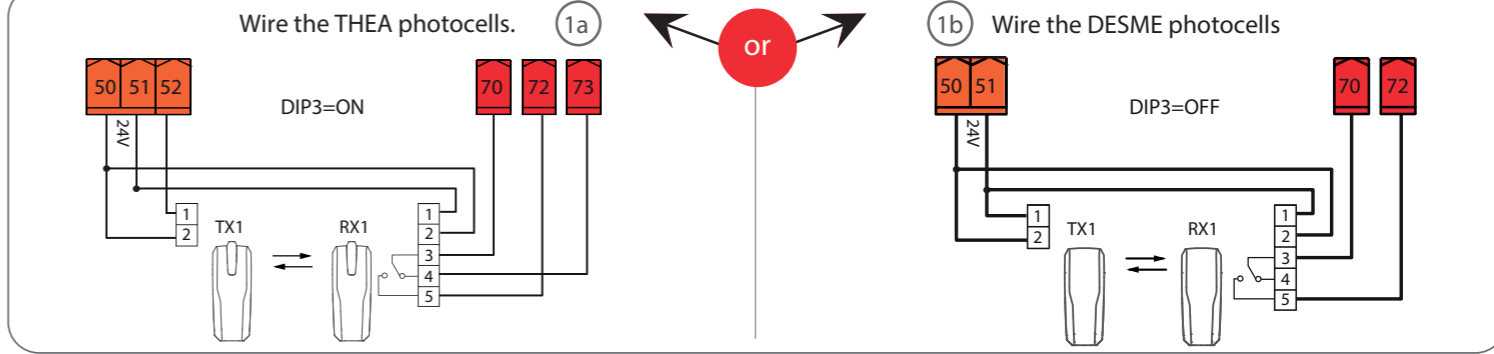

As an option, to go further....

- 1 - I wish to deactivate the photocells during opening: Place dipswitch 5 in the ON position.
- 2 - I wish to activate and adjust automatic closure: This is done by regulating the T1 potentiometer. Please refer to the remote control programming by pressing S2.
- 3 - I wish to activate pedestrian opening: