

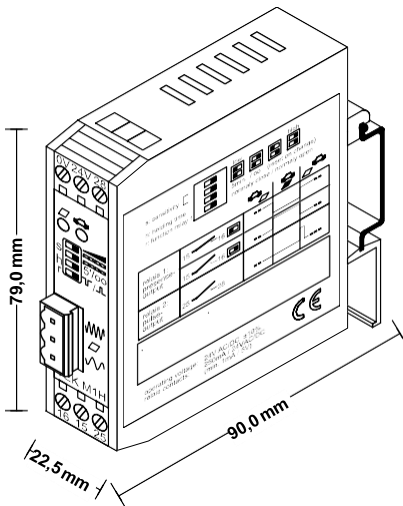

Operation Instruction

VEK M1H

1-channel induction loop detector for installation on DIN-rail



Please read these instructions and safety information and warnings attentively before initial operation of the detector !

1 General

Applications:

- Barrier controls
- Door and gate controls
- Parking and traffic technology

Features:

The induction loop detector VEK M1H is a system for inductive recognition of vehicles with the following characteristics:

- Isolated transformer between loop and detector electronics
- Automatic calibration of the system after switching on
- Continuous rebalancing of frequency drifts
- Usable for single place parking space supervising
- Sensitivity independent of the loop inductivity
- Presence signal by LED display
- Potential free relay contacts for presence and pulse output
- Pulse output while leaving the loop
- Signalling of loop frequency by LED
- Loop connection plug-in for diagnosis

For planning and installation of loops please note our manual "detection of vehicles with the induction loop detector".

2 Setting options

2.1 Sensitivity

The setting of the sensitivity calls the electronics to a value of frequency deviation which a vehicle must produce for setting the output of the detector. The sensitivity can be adjusted in 4 steps with the two DIP-switches 's' on top of the front panel.

sensitivity step	DIP-switch 's'
1 low (0,64 % Δf/f)	
2 (0,16 % Δf/f)	
3 (0,04 % Δf/f)	
4 high (0,01 % Δf/f)	

2.2 Hold time and Reset

The hold time can be adjusted with DIP-switch 'h'.

At the completion of hold time it will be displayed "free loop" and the detector calibrates automatically. The hold time starts with the occupation of the loop.

hold time	DIP-switch 'h'
5 minutes	
infinite	

An automatic calibration of the loop frequency will be done by the detector after switch-on of the power supply. In case of short power cuts <0,1 s there is no calibration.

A reset with calibration can be effected by changing the hold time setting.

2.3 Operation principle of the presence relay

The detector has one relay for presence output and another relay for pulse output each with a potential free contact. The operation principle of the presence relay can be changed with the DIP-switch 'r'

operation principle presence relay	DIP-switch 'r'
contact normally closed	
contact normally open	

2.4 Frequency adjustment

The operation frequency of the detector can be adjusted in two steps by the 3-pole connection jack in the front panel. The permissible frequency range is 30 kHz to 130 kHz. The frequency depends on the loop inductivity (depending itself on: loop geometry, number of loop turns and loop lead) and the adjusted frequency step.

upper position = high frequency
lower position = low frequency

3 Outputs and LED

3.1 Contact mode of the relays

The following table shows the state of the relay contacts depending on the detector mode.

detector mode	presence relay		pulse relay
free loop	close	open	open
covered loop	open	close	open
loop gets free	close	open	200 ms pulse
loop failure	open	close	open
power off	close	close	open

In case of a loop failure the detector checks the loop condition cyclically and continues automatically after elimination.

3.2 LED signals

The green LED signals that the detector is ready for operation. Via the red LED, the activation of the relays output is announced depending on the occupation status of the loop.

LED green loop control	LED red loop condition	detector function
off	off	power off
flashing	off	calibration or output of frequency
on	off	detector ready for operation, free loop
on	on	det. ready f. operation, covered loop
off	on	loop failure

3.3 Output of loop frequency

Approx. 1 sec. after calibration of the detector the loop frequency will be displayed by pulse signals of the green LED. Firstly the 10 kHz position of the frequency value will be indicated. For every 10 kHz frequency value the green LED flashes once. After a break of 1 sec the 1 kHz position is displayed in the same manner. If there is value of '0' in the 1 kHz position there will be displayed 10 flashes. The flashes for 1 kHz position are a little bit shorter than for the 10 kHz position.

Example for 57 kHz loop frequency:

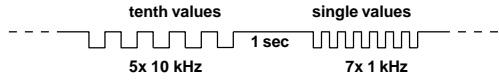

4 Safety information and warnings

- The device should only used for the applications described by the manufacturer.
- Please keep this operation instruction always accessible and hand it over to every user.
- Inadmissible modifications to the device, use of repair parts and supplementary equipment which are not sold or recommended by the manufacturer can cause burning, electric shock and injuries. Therefore the manufacturer has no liability and this excludes all demands of warranty.
- The warranty regulations of the manufacturer are valid in the version of the purchase date for that device. There is no liability for not suitable, wrong manual or automatic adjustments also regarding no suitable applications of the device.
- Repairs may only made by the manufacturer.
- The power supply must be fulfill the requirements for SELV and limited power sources according to EN 60950-1.
- All connections, the start-up, maintenance, measurements and adjustment operations to the detector have to be made from electrical specialists who have special know-how in the prevention of accidents.
- For the use of devices which have contact to electrical power, please pay attention to the valid security instructions and all prevention orders of fire and accidents.
- The user is responsible for an installation, which has conformity to all technical rules in the country where the device is mounted, and also to all regional valid orders. For that the dimension of cabling, fuse protection, connection to ground, switch off, disconnection, isolation controlling and the protection for overload current have to be regarded in detail.
- The detector can not be used as a security device regarding to the security instructions of electrical machines. Using in systems with high danger potential it is necessary to include additional protection devices!
- All work on the device must be carried out in accordance with the national electrical codes and regional regulations.



5 Technical data

Dimensions	79 x 22,5 x 90 mm (h x w x d without plug)
Protection class	IP 20
Power supply	24 V AC/DC ±10 % max.1,5 W SELV
Operating temperature	-20 °C to +70 °C
Storing temperature	-20 °C to +70 °C
Humidity	max. 95 % not condensing
Loop inductivity	25-800 µH, recommended 100-300 uH
Frequency range	25-130 kHz in 2 steps
Sensitivity	0,01 % up to 0,65 % (Δf/f) in 4 steps 0,02 % up to 1,3 % (ΔL/L)
Hold time	5 minutes or infinite
Loop lead length	max. 250 m
Loop resistance	max. 20 Ohm (incl. loop lead)
Relays	250 mA / 24 V AC/DC (min. 1 mA/5 V)
presence relay	contact n.c. (adjust. operation principle)
pulse relay	contact n.o.
Signal duration	> 200 ms
Cycle time	40 ms (reaction time 80 ms)
Connections	screw terminals (power supply, relays) binder plug (loop connection)

6 Connections

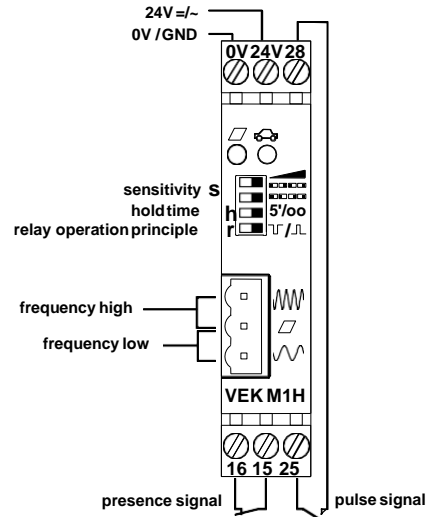

Note

The information in this instruction can be changed without previous announcement.
 With this description all previous issues lose their validity.
 The summary of information in this description was done with all possible acknowledge and by the best conscience.
 FEIG ELECTRONIC can't give guaranty for the correctness of all information. Particularly there is no liability by FEIG ELECTRONIC for damages which result from a wrong installation of the device.
 In spite of all efforts to correctness we are very thankful for every point to a mistake in this description.
 The installation recommendations in this description are based on optimum conditions. For wrong environment conditions FEIG ELECTRONIC doesn't give a warranty to optimum operation of the detector.

You can download the EC declaration of conformity and other important documents from www.feig.de.

7 Instructions for the installation of induction loops

- The induction loops must be installed at least 15 cm from fixed metal objects and at least 1 m from moving metal objects. The maximum distance to the road surface should be 5 cm.
- Keep loop cables away from mains power cables.
- Use a normal single-pole 1.5 mm² diameter cable. If the cable is buried directly, it must have a suitable insulation. If hot casting compound is used ensure for temperature resistance of the cable.
- Preferably, induction loops are made square or rectangular. If it is not possible to use pre-fabricated loops, the installation is performed as shown in the figure below, in a groove cut into the road surface. In this case, the loop cable must be firmly fixed in the groove and then the groove must be filled with the potting compound. The corners should be at an angle of 45° to avoid damage to the insulation of the cable.

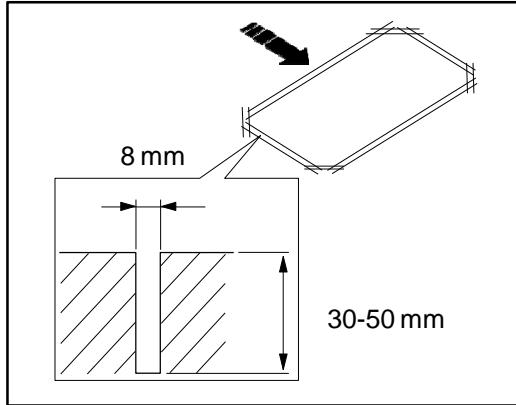

- For installation of the loop cable use the number of turns indicated in the table.

Induction loop perimeter	Number of turns
less than 3 m	6
from 3 to 4 m	5
from 4 to 6 m	4
from 6 to 12 m	3
over 12 m	2

- The two cable ends from the loop to the detector must be twisted at least 20 times per meter.
- Do not make any joints on the cable. If this is still necessary, the contact points must be protected against the ingress of moisture by means of cast resin.

Declaration of Conformity

in accordance with the
Electromagnetic Compatibility (EMC)
Directive 2014/30/EU

and

RoHS 2 Directive 2011/65/EU

FEIG ELECTRONIC

Product Manufacturer : **FEIG ELECTRONIC GmbH**
Lange Strasse 4
D-35781 Weilburg
Germany
Phone +49 6471 3109 0

Product Designation : **VEK M1H, VEK M2H**

Product Description : 1-/2-Channel Induction Loop Detector

FEIG ELECTRONIC GmbH herewith declares the conformity of the product with applicable regulations below.

Standards applied :

Electromagnetic compatibility (EMC) **EN 61000-6-2:2005 / AC:2005**
Part 6-2: Generic Standards
Immunity for industrial environments

Electromagnetic compatibility (EMC) **EN 61000-6-3:2007 + A1:2011**
Part 6-3: Generic standards
Emission standard for residential, commercial and
light-industrial environments

Weilburg-Waldhausen, 03/02/2017

Place & date of issue



Dirk Schäfer (Technical Director)
CONTROLLER & SENSORS

This declaration attests to conformity with the named Directives but does not represent assurance of properties.
The safety guidelines in the accompanying product documentation must be observed.